

# Amplifier and Data Converter Selection Guide

3Q 2006

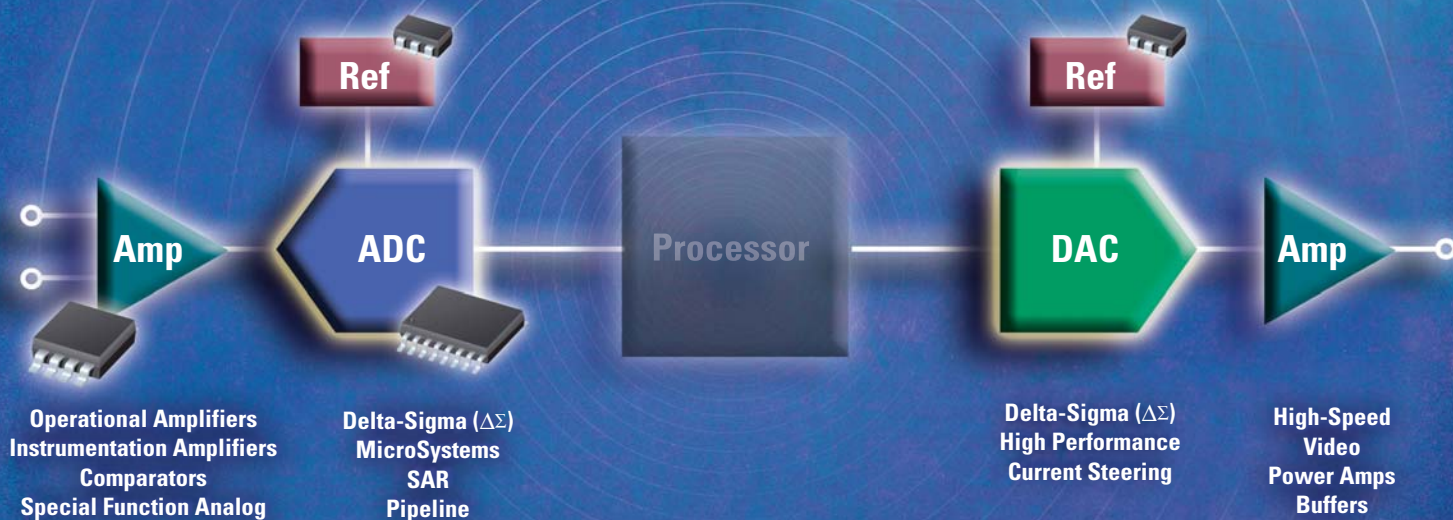



## Signal Chain

### Amplifiers

### Analog-to-Digital Converters

### Digital-to-Analog Converters

### Analog Monitoring and Control

### Voltage References

### Temperature Sensors

### High Reliability Products

### Technical Support

### Inputs

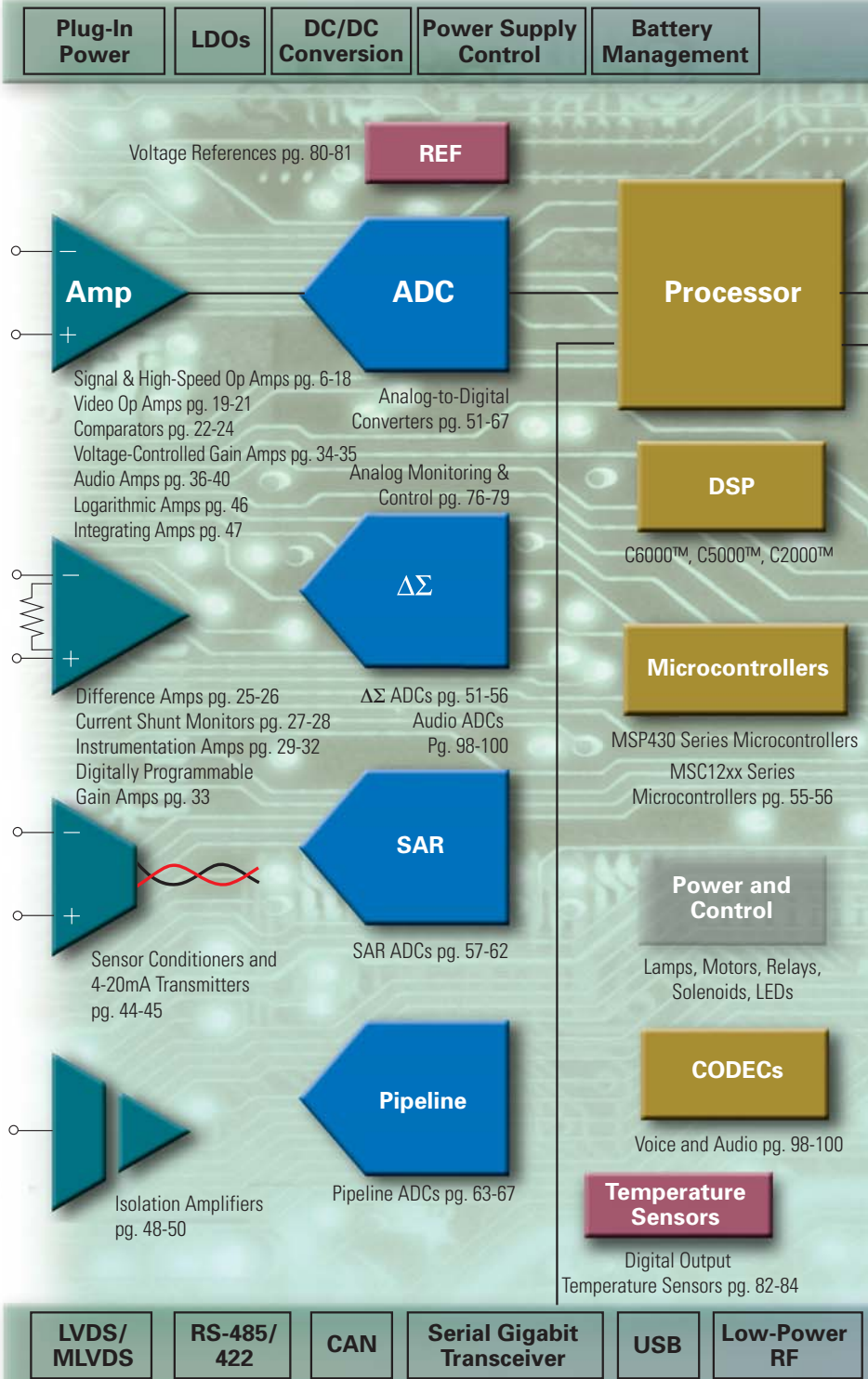



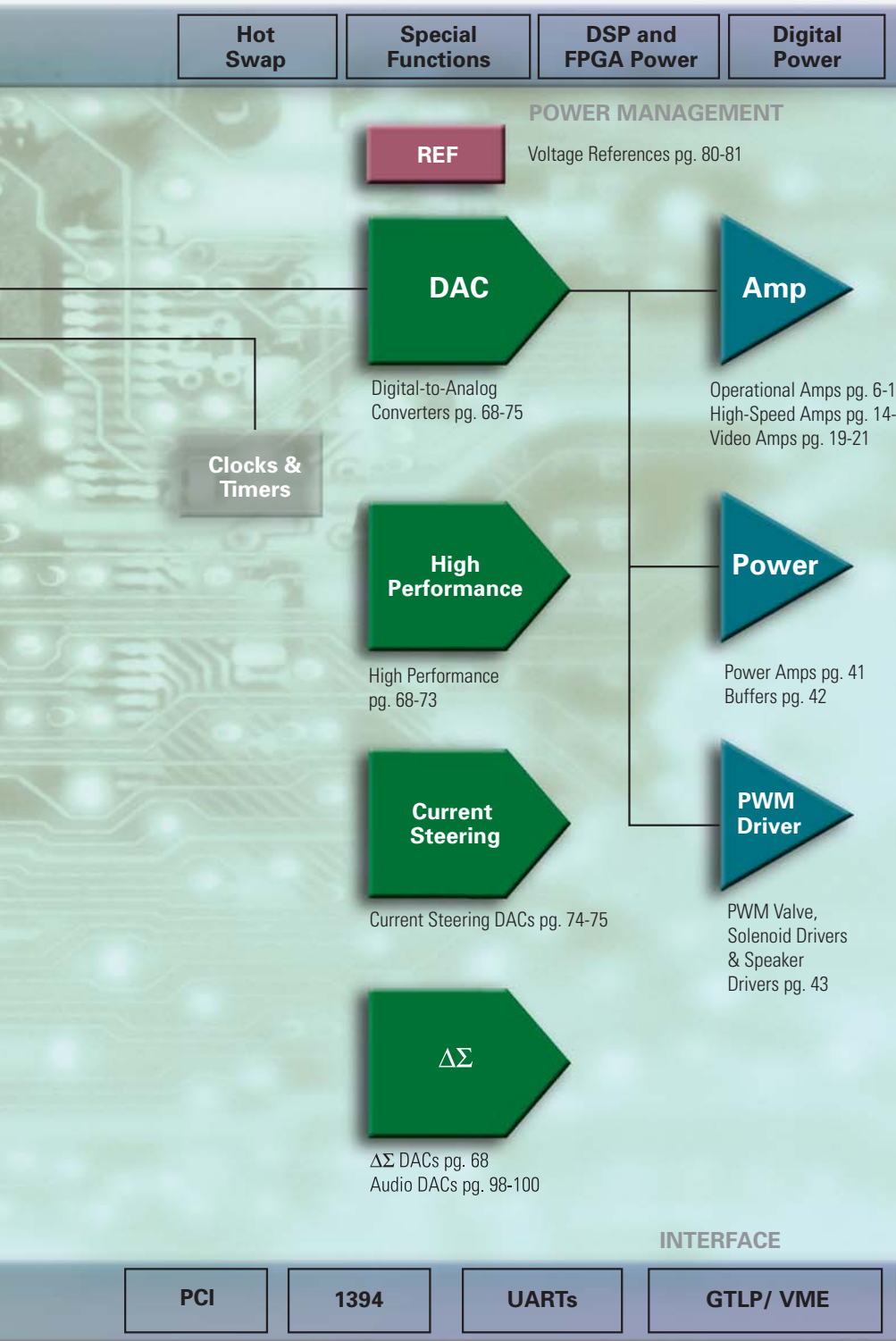

**Outputs**

- 
- 
- 
- 
- 
- 
- 
- 
- 

- Amplifiers**
  - Operational Amplifiers
  - High-Speed Amplifiers
  - Comparators
  - Instrumentation Amplifiers
  - Signal Conditioning
  - Power Amps and Buffers
  - Special Function Analog

---

- Analog-to-Digital Converters**
  - Delta-Sigma ADCs
    - MSC12xx MicroSystems
  - SAR ADCs
  - Pipeline ADCs
  - Audio

---

- Digital-to-Analog Converters**
  - Delta-Sigma DACs
  - High-Performance DACs
  - Current Steering DACs
  - Audio

---

- Analog Monitoring and Control**

---

- Voltage References**

---

- Temperature Sensors**

---

- High Reliability Products**

---

- Technical Support**
  - Technology Primer
  - Evaluation Modules
  - Application Reports
  - Part Finder



## Table of Contents

### Operational Amplifiers <50MHz

Overview	6-7
Precision Op Amps	8
Low Supply Current	9
Low Offset Voltage	10
Low Noise	11
Wide Bandwidth	11
Wide Supply Voltage	12
Low Input Bias Current	12
Single Supply Voltage	13

### High-Speed Amplifiers >50MHz

Overview	14-18
Video	19-21

### Comparators **22-24**

### Difference Amplifiers **25-26**

### Current Shunt Monitors

Overview	27
Analog Output Current Shunt Monitors	27-28
Digital Output Current Shunt Monitors	79

### Instrumentation Amplifiers

Overview	29
Single Supply	30-31
Dual Supply	32

### Digitally Programmable Gain Amplifiers **33**

### Voltage-Controlled Gain Amplifiers **34-35**

### Audio Amplifiers

Overview	36
Audio Power Amplifiers	37-39
Digitally Controlled Microphone Preamplifier	40

### Power Amplifiers and Buffers **41-42**

### Pulse Width Modulation Drivers **43**

### Sensor Conditioners/4-20mA Transmitters **44-45**

### Logarithmic Amplifiers **46**

### Integrating Amplifiers **47**

### Isolation Products **48**

### Amplifiers for Driving ADCs **49-50**



## Analog-to-Digital Converters (ADCs) by Architecture

Delta-Sigma ( $\Delta\Sigma$ ) ADCs	.51-54
MSC12xx Intelligent ADCs w/ Delta-Sigma ADC/DAC	.55-56
SAR ADCs	.57-62
Pipeline ADCs	.63-67
Audio ADCs and CODECs	.98-100
Touch Screen Controllers	.100

## Amplifiers for Driving ADCs 49-50

## Digital-to-Analog Converters (DACs) by Architecture

Delta-Sigma ( $\Delta\Sigma$ ) ADCs	.68
High Performance DACs (previously String and R-2Rs)	.68-73
Current Steering DACs	.74-75
Audio DACs	.98-100

## Analog Monitoring and Control

AMC Products	.76-78
Digital Current Shunt Monitors	.79

## Voltage References .80-81

## Temperature Sensors .82-84

Fan Controllers	84
-----------------	----

## High Reliability Amplifiers and Data Converters 85

## Quick Reference Selection Tables for Data Converters

Quick Reference ADC Selection Tables	.86-93
Quick Reference DAC Selection Tables	.94-97
Quick Reference Audio Converters Selection Tables	.98-100
Quick Reference Touch Screen Controllers with/without Audio Selection Tables	.100

## Design and Evaluation Tools

TINA-TI™/Spice Module	.101
Modular ADC and DAC Evaluation Tool	.102-103
Data Converter Plug-In (DCP) for Code Composer Studio™ IDE	.104-107
Application Reports	.108-110
Device Index	.111-114
Worldwide Technical Support	.115



Texas Instruments (TI) offers a wide range of op amp types including high precision, microPower, low voltage, high voltage, high speed and rail-to-rail in several different process technologies. TI has developed the industry's largest selection of low-power and low-voltage op amps with features designed to satisfy a very wide range of applications. To help facilitate the selection process, an interactive online op amp parametric search engine is available at [amplifier.ti.com/search](http://amplifier.ti.com/search) with links to all op amp specifications.

### Design Considerations

Choosing the best op amp for an application involves consideration of a variety of inter-related requirements. In doing so, designers must often consider conflicting size, cost and performance objectives. Even experienced engineers can find the task daunting, but it need not be so. Keeping in mind the following issues, the choices can quickly be narrowed to a manageable few.

**Supply voltage ( $V_S$ )**—tables include low voltage (< 2.7V min) and wide voltage range (> 5V min) sections. Other op amp selection criteria (e.g., precision) can be quickly examined in the supply range column for an appropriate choice. Applications operating from a single power supply may require rail-to-rail performance and consideration of precision-related parameters.

**Precision**—primarily associated with input offset voltage ( $V_{OS}$ ) and its change with respect to temperature drift, PSRR and CMRR. It is generally used to describe op amps with low input offset voltage and low input offset voltage temperature drift. Precision op amps are required when amplifying tiny signals from thermocouples and other low-level sensors. High-gain or multi-stage circuits may require low offset voltage.

**Gain bandwidth product (GBW)**—the gain bandwidth of a voltage-feedback op amp determines its useful bandwidth in an application. The maximum available bandwidth is approximately equal to the gain bandwidth divided by the closed-loop gain of the application. For voltage feedback amplifiers, GBW is a constant. Many applications benefit from choosing a much wider bandwidth/slew rate

op amp to achieve low distortion, excellent linearity, good gain accuracy, gain flatness or other behavior that is influenced by feedback factors.

**Power ( $I_Q$  requirements)**—a significant issue in many applications. Because op amps can have a considerable impact on the overall system power budget, quiescent current, especially in battery-powered applications, is a key design consideration.

**Rail-to-rail performance**—rail-to-rail output provides maximum output voltage swing for widest dynamic range. This may be particularly important with low operating voltage where signal swings are limited. Rail-to-rail input capability is often required to achieve maximum signal swing in buffer ( $G = 1$ ) single-supply applications. It can be useful in other applications, depending on amplifier gain and biasing considerations.

**Voltage noise ( $V_N$ )**—amplifier-generated noise may limit the ultimate dynamic range, accuracy or resolution of a system. Low-noise op amps can improve accuracy, even in slow DC measurements.

**Input bias current ( $I_B$ )**—can create offset error by reacting with source or feedback impedance. Applications with high source impedance or high impedance feedback elements (such as transimpedance amplifiers or integrators) often require low input bias

current. FET-Input and CMOS op amps generally provide very low input bias current.

**Slew rate**—the maximum rate of change of the amplifier output. It is important when driving large signals to high frequency. The available large signal bandwidth of an op amp is determined by the slew rate ( $f = SR/2\pi A$ ).

**Package size**—TI offers a wide variety of microPackages, including WCSP, SOT23, SC70 and small, high power-dissipating PowerPAD™ packages to meet space-sensitive and high-output drive requirements. Many TI single-channel op amps are available in SOT23, with some dual amplifiers in SOT23-8.

**Shutdown mode**—an enable/disable function that places the amp in a high impedance state, reducing quiescent current in many cases to less than 1μA. Allows designers to use wide bandwidth op amps in lower power applications, enabling them only when they are needed.

**Decompensated amplifiers**—for applications with gain greater than unity gain ( $G > 1$ ), decompensated amps provide significantly higher bandwidth, improved slew rate and lower distortion over their unity-gain stable counterparts on the same quiescent current or noise.

## Common Op Amp Design Questions

### What is the amplitude of the input signal?

To ensure signal errors are small relative to the input signal, small input signals require high precision (e.g., low offset voltage) amplifiers. Ensure that the amplified output signal stays within the amplifier output voltage.

### Will the ambient temperature vary?

Op amps are sensitive to temperature variations, so it is important to consider offset voltage drift over temperature.

### Does the common-mode voltage vary?

Make sure the op amp is operated within its common-mode range and has an adequate common-mode rejection ratio

(CMRR). Common-mode voltage will induce additional offset voltage.

### Does the power supply voltage vary?

Power supply variations affect the offset voltage. This may be especially important in battery-powered applications.

### Precision Application Examples

- High gain circuits ( $G > 100$ )
- Measuring small input signals (e.g., from a thermocouple)
- Wide operating temperature range circuits (i.e., in automotive or industrial applications)
- Single-supply  $\leq 5V$  data-acquisition systems where input voltage span is limited



## Technology Primer

Understanding the relative advantages of basic semiconductor technologies will help in selecting the proper device for a specific application.

**CMOS Amps**—when low voltage and/or low power consumption, excellent speed/power ratio, rail-to-rail performance, low cost and small packaging are primary design considerations, choose micropackaged CMOS amps boasting the highest precision in the industry.

**High-Speed Bipolar Amps**—when the highest speed at the lowest power is required, bipolar technology delivers the best performance. Extremely good power gain gives very high output power and full power bandwidths on the lowest quiescent power. Higher voltage requirements are also only satisfied in bipolar technologies.

**Precision Bipolar Amps**—excel in limiting errors relating to offset voltage. These amps include low offset voltage and temperature drift, high open-loop gain and common-mode rejection. Precision bipolar op amps are used extensively in applications where the source

impedance is low, such as a thermocouple amplifier, and where voltage errors, offset voltage and drift, are crucial to accuracy.

**Low  $I_B$  FET Amps**—when input impedance is very high, FET-input amps provide better overall precision than bipolar-input amps because of very low input bias current. Using a bipolar amp in applications with high source impedance (e.g., 500M $\Omega$  pH probe), the offset, drift and noise produced by bias currents flowing through the source would render the circuit virtually useless. When low current errors are required, FET amps provide extremely low input bias current, low offset current and high input impedance.

**Dielectrically Isolated FET (Difet™) Amps**—Difet processing enables the design of extremely low input leakage amplifiers by eliminating the substrate junction diode present in junction isolated processes. This technique yields very high-precision, low-noise op amps. Difet processes also minimize parasitic capacitance and output transistor saturation effects, resulting in improved bandwidth and wider output swing.

## Op Amp Rapid Selector

The tables on the following pages have been subdivided into several categories to help quickly narrow the alternatives.

### Low Supply Current

( $I_Q \leq 1\text{mA}$ ) Pg. 9

### Low Voltage Offset

( $V_S \leq 500\mu\text{V}$ ) Pg. 10

### Low Noise

( $V_N \leq 10\text{nV}/\sqrt{\text{Hz}}$ ) Pg. 11

### Wide Bandwidth, Precision

GBW  $\geq 5\text{MHz}$  Pg. 11

### Wide Voltage Range

( $\pm 5 \leq V_S \leq \pm 20\text{V}$ ) Pg. 12

### Low Input Bias Current

( $I_B \leq 10\text{pA}$ ) Pg. 12

### Single Supply

( $V_S(\text{min}) \leq 2.7\text{V}$ ) Pg. 13

### High Speed

BW  $\geq 50\text{MHz}$  Pg. 14

## Operational Amplifier Naming Conventions

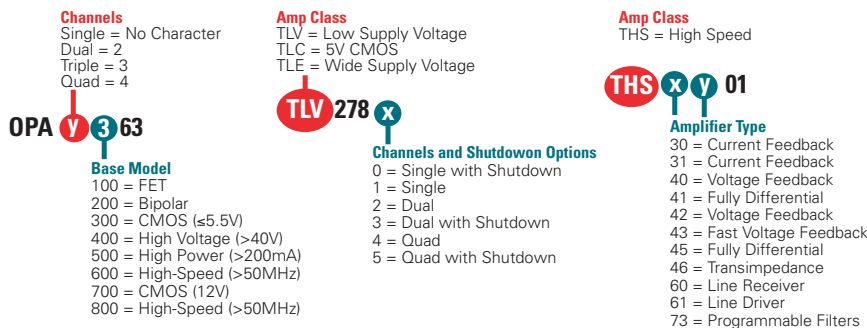

Supply Voltage	Design Requirements	Typical Applications	Recommended Process	Recommended TI Amp Family
$V_S \leq 5\text{V}$	Rail-to-Rail, Low Power, Precision, Small Packages	Battery Powered, Handheld	CMOS	OPA3xx, TLVxxxx
$V_S \leq 16\text{V}$	Rail-to-Rail, Low Noise, Low Voltage Offset, Precision, Small Packages	Industrial, Automotive	CMOS	OPA3x, TLCxxxx, OPA7xx
$V_S \leq +3\text{V}$	Low Input Bias Current, Low Offset Current, High Input Impedance	Industrial, Test Equipment, Optical Networking (ONET), High-End Audio	FET, Difet	OPA1xx, OPA627
$V_S \leq +44\text{V}$	Low Voltage Offset, Low Drift	Industrial, Test Equipment, ONET, High-End Audio	Bipolar	OPA2xx, TLExxxx
$\pm 5\text{V}$ to $\pm 15\text{V}$ Dual Supply	High Speed on Dual Supplies	XDSL, Video, Professional Imaging, Data Converter Signal Conditioning	Difet, High-Speed Bipolar, BiCOM	OPA6xx*, OPA8xx* THSxxxx*
$2.7\text{V} \leq V_S \leq 5\text{V}$ Single Supply	High Speed on Single Supply	Consumer Imaging, Data Converter Signal Conditioning, Safety-Critical Automotive	High-Speed CMOS	OPA35x, OPA6xx*, THSxxxx*, OPA8xx*

\*See High-Speed section, Page 14-18

## → Precision Operational Amplifiers

### Zero-Drift, 17 $\mu$ A Supply Current, 2 $\mu$ V Offset, Rail-to-Rail I/O, Operational Amplifier OPA333, OPA2333

NEW

Get samples, datasheets, and app reports at: [www.ti.com/OPA333](http://www.ti.com/OPA333)

#### Key Features

- Low power: 25 $\mu$ A (max)
- Low offset voltage: 10 $\mu$ V (max)
- Low offset drift: 0.05 $\mu$ V (max)
- Rail-to-rail input and output
- Single supply: 1.8V to 5.5V
- Input voltage range: 100mV beyond supply rails
- Available in single, dual: OPA333, OPA2333
- Packaging: SC-70, SOT23-5, SO-8

#### Applications

- Low-power signal conditioning
- Low-power data acquisition
- Electronic scales
- Medical instrumentation
- Battery powered monitors
- Smoke and gas detectors

The OPA333 is the industry's lowest-power, zero-drift amplifier. The OPA333 delivers 10 $\mu$ V of offset voltage and 0.05 $\mu$ V/ $^{\circ}$ C offset drift on supplies from 1.8V to 5.5V. Developed for low-power applications that demand precision performance, the OPA333 was designed using CMOS technology and a patented input topology that features an auto-calibration technique to create a time and temperature stable input on 25 $\mu$ A (max) supply current. The common-mode input range extends 100mV beyond the supply rails and outputs swing within 40mV of the supply rails. The OPA333 is available in the micro-sized SC70 or SOT23 packages, and is specified for operation from  $-40^{\circ}$ C to  $+125^{\circ}$ C.

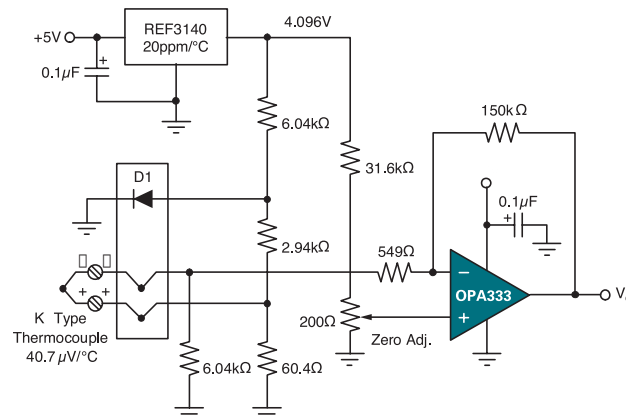

OPA333 configured for thermocouple temperature measurement.

### 1.8V, Low Noise, microPower Operational Amplifier OPA379

NEW

Get samples, datasheets, and app reports at: [www.ti.com/sc/device/OPA379](http://www.ti.com/sc/device/OPA379)

#### Key Features

- Low offset voltage: 1.5mV (max)
- Single supply: 1.8V to 5.5V
- Low power: 10 $\mu$ A (max)
- Excellent bandwidth: 90kHz
- Rail-to-rail input and output
- Low input bias current: 50pA (max)
- Low noise: 80nV/ $\sqrt{\text{Hz}}$
- Micro Packaging: SC-70

#### Applications

- Battery-powered instruments
- Photodiode monitoring
- Portable devices
- High-impedance applications
- Medical instruments
- Precision integrators

The OPA379 combines ultra-low power (10 $\mu$ A max), 1.8V supply, and extremely low noise and low offset (1.5mV max). Offering an impressive 90kHz bandwidth, it is available in the small SC-70 package. The OPA379 also offers true rail-to-rail performance, making it useful in a wide range of power-sensitive applications.

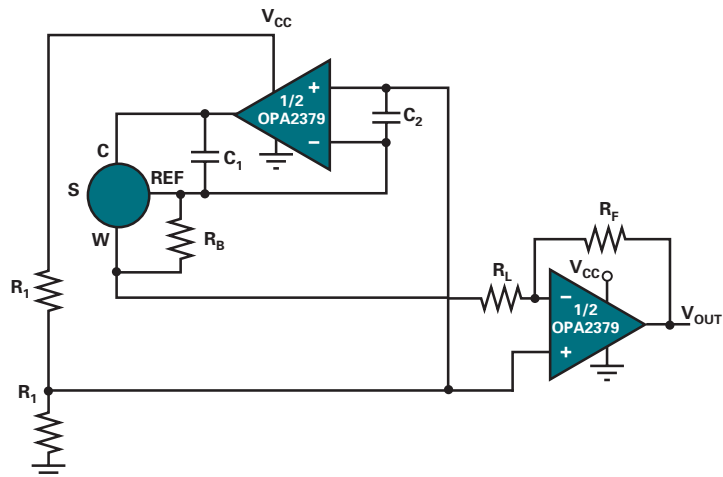

OPA379 in a portable gas meter application.





### 2.2V, 50MHz, 5nV/√Hz, Zero-Crossover, Operational Amplifier OPA365

NEW

Get datasheets at: [www.ti.com/OPA365](http://www.ti.com/OPA365)

#### Key Features

- Wide bandwidth: 50MHz
- High slew rate: 25V/μs
- Low noise: 5nV/√Hz
- Low THD+N: 00006%
- Low offset: 500μV (max)
- CMRR: 100dB
- Rail-to-rail input/output: (10mV beyond supply rails) without crossover
- Available in single, dual: OPA365, OPA2365
- Micro Packaging: SOT23-5, SO-8, DFN-8

#### Applications

- Precision signal conditioning
- Data acquisition
- Process control
- Test equipment
- Active filters
- Audio

The OPA365 is the newest member of the Zero-Crossover™ family of op amps featuring TI's patented single-supply, zero-crossover input stage designed to offer excellent performance for very low-voltage, single-supply ADC applications. These amplifiers are optimized for driving 16-bit SAR ADCs and feature precision CMRR without the crossover associated with traditional complementary input stages. The input common-mode range includes both the negative and positive supplies and the output voltage swing is 10mV beyond supply rails. All versions are specified for operation from -40°C to +125°C. The OPA365 operates on single supplies from 2.2V (±1.1V) to 5.5V (±2.25V), and features 500μV offset on 5mA supply current.

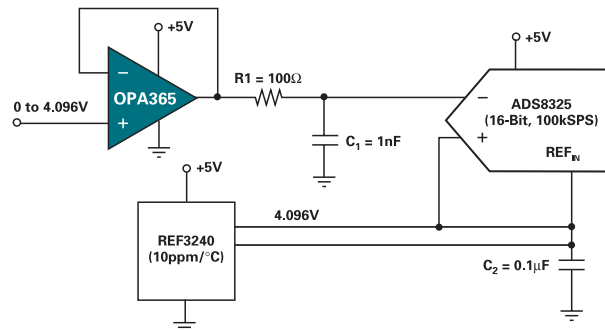

OPA365 functional block diagram.

### Low-Power Operational Amplifiers ( $I_Q \leq 1\text{mA}$ ) Selection Guide

Device	Description	Ch.	V <sub>S</sub> (V)	V <sub>S</sub> (V)	I <sub>Q</sub> Per Ch. (mA)	GBW (MHz)	Slew Rate (V/μs)	V <sub>OS</sub> (mV)	Offset Drift (μV/°C)	I <sub>B</sub> (pA)	V <sub>N</sub> at 1kHz (nV/√Hz)	Rail-to-Rail	Package(s)	Price*
TLV240x	2.5V, Sub-μPower, SS, CMOS	1, 2, 4	2.5	16	0.00095	0.0055	0.0025	1.2	3	300	—	I/O	MSOP, PDIP, SOIC, SOT23, TSSOP	\$0.65
TLV224x	Low Voltage, 1μA, SS, CMOS	1, 2, 4	2.5	12	0.0012	0.0055	0.002	3	3	500	—	I/O	MSOP, PDIP, SOIC, SOT23, TSSOP	\$0.60
OPAy349	1μA, SS, CMOS	1, 2	1.8	5.5	0.002	0.07	0.02	10	10	15	—	I/O	SC70, SOIC, SOT23	\$0.75
<b>OPAy333</b>	μPower, SS, RRIO, Zero Drift, CMOS	1, 2	1.8	5.5	0.025	0.35	0.16	0.01	0.05	200	106	I/O	SC70, SOT23, SOIC	\$0.95
<b>OPA379</b>	1.8V, Ultra-Low Power, CMOS	1, 2, 4	1.8	5.5	0.005	0.1	0.03	1.5	2.7	50	100	I/O	SC70, SOT23, SOIC	\$0.75
TLC1078	Low Voltage, Precision, Bipolar	2	1.4	16	0.017	0.085	0.032	0.45	1.1	600	68	Out	SOIC, PDIP	\$2.30
OPAy241	Bipolar, μPower, High CMRR, Bipolar	1, 2, 4	2.7	36	0.035	0.35	0.1	0.25	0.4	20000	45	Out	PDIP, SOIC	\$1.15
OPAy336	μPower, SS, CMOS	1, 2, 4	2.3	5.5	0.032	0.1	0.03	0.125	1.5	10	40	Out	SOT23, SOIC	\$0.40
OPAy347	μPower, Low Cost, SS, CMOS	1, 2, 4	2.3	5.5	0.034	0.35	0.17	6	2	10	60	I/O	SC70, SOT23, SOIC, PDIP	\$0.48
TLV245x	μPower, SS, CMOS	1, 2, 4	2.7	6	0.035	0.22	0.12	1.5	0.3	5000	51	I/O	SOT23, SOIC, PDIP	\$0.60
OPAy251	μPower, Precision, Bipolar	1, 2, 4	2.7	36	0.038	0.035	0.01	0.25	0.5	20000	45	Out	SOIC, PDIP	\$1.15
OPAy244	μPower, SS, Low Cost, Bipolar	1, 2, 4	2.7	36	0.05	0.24	0.1	1.5	4	25000	22	N	MSOP, PDIP, SOIC, SOT23, TSSOP	\$0.55
OPAy348	High Open-Loop Gain, SS, CMOS	1, 2, 4	2.1	5.5	0.065	1	0.5	5	2	10	35	I/O	SC70, SOIC, SOT23, CSP	\$0.45
OPA234	Low Power, Precision	1, 2, 4	2.7	36	0.3	0.35	0.2	0.1	0.5	25000	24	N	MSOP, SOIC	\$1.05
OPAy334/5	Zero Drift, Precision, CMOS, SS, SHDN	1, 2	2.7	5.5	0.35	2	0.5	0.005	0.02	200	—	Out	MSOP, SOIC, SOT23	\$1.00
TLV246x	Low Noise, SS, Wide BW, CMOS	1, 2, 4	2.7	6	0.575	5.2	1.6	2	2	14000	11	I/O	SOT23, SOIC, TSSOP, PDIP	\$0.60
OPAy373/4	Low Voltage, SS, Low Cost CMOS	1	2.7	5.5	0.75	6.5	5	5	3	10	—	I/O	SOT23, SOIC	\$0.36
OPAy363/4	1.8V, High CMRR, SS, SHDN	1, 2, 4	1.8	5.5	0.75	7	5	0.5	3	10	—	I/O	SOT23, SOIC	\$0.60
OPAy734/5	12V Auto-Zero Precision, SHDN	1, 2	2.7	12	0.75	1.5	1.6	0.005	0.01	200	—	Out	SOT23, SOIC	\$1.25
TLV247x	Low Power, SS, Low	1, 2, 4	2.7	6	0.75	2.8	1.4	2.2	0.4	50	15	I/O	SOT23, SOIC, PDIP	\$0.60
TLV278x	1.8V, Low Power, SS	1, 2, 4	1.8	3.6	0.82	8	4.3	3	8	15	18	I/O	SOT23, SOIC	\$0.65
OPAy277	High Precision, Bipolar	1, 2, 4	4	36	0.825	1	0.8	0.02	0.1	1000	8	N	SOIC, PDIP	\$0.85
OPAy340	Wide Bandwidth, CMOS	1, 2, 4	2.7	5.5	0.95	5.5	6	0.5	2.5	10	25	I/O	SOT23, SOIC, PDIP	\$0.80
<b>THS4281</b>	High Speed, Low Power	1	2.7	15	1	40	35	3.5	7	10	12.5	I/O	SOT23, MSOP, SOIC	\$0.95

\*Suggested resale price in U.S. dollars in quantities of 1,000.

New products are listed in bold red.



## Precision Operational Amplifiers

### Precision, Offset Voltage Operational Amplifiers ( $V_{OS} \leq 500\mu V$ )

Device	Description/Technology	Ch.	$V_S$ (V) (min)	$V_S$ (V) (max)	$I_Q$ Per Ch. (mA) (max)	GBW (MHz) (typ)	Slew Rate (V/ $\mu$ s) (typ)	$V_{OS}$ (25°C) (mV) (max)	$V_{OS}$ Drift ( $\mu$ V/°C) (typ)	$I_B$ (pA) (max)	CMRR (dB) (min)	$V_N$ at 1kHz (nV/ $\sqrt{Hz}$ ) (typ)	Single Supply	Rail- to- Rail	Package(s)	Price*
<b>OPAy333</b>	$\mu$ Power, Zero Drift, CMOS	1, 2	1.8	5.5	0.025	.350	0.16	0.010	0.05	200	106	—	Y	I/O	SC70, SOT23, SOIC	\$0.95
OPAy334	Zero Drift, SHDN, CMOS	1, 2	2.7	5.5	0.35	2	1.6	0.005	0.02	200	110	—	Y	Out	SOT23, MSOP, SOIC	\$1.00
OPAy335	Zero Drift, CMOS	1, 2	2.7	5.5	0.35	2	1.6	0.005	0.02	200	110	—	Y	Out	SOT23, SOIC	\$1.00
OPAy734	12V, Auto-Zero, SHDN, CMOS	1, 2	2.7	12	0.75	1.6	1.5	0.005	0.01	200	115	110	Y	Out	SOT23, SOIC	\$1.25
OPAy735	12V, Auto-Zero, CMOS	1, 2	2.7	12	0.75	1.6	1.5	0.005	0.01	200	115	110	Y	Out	SOT23, MSOP	\$1.25
OPAy277	Precision, Bipolar	1, 2, 4	4	36	0.825	1	0.8	0.02	0.1	1000	130	8	N	N	SON, SOIC, PDIP	\$0.85
<b>OPAy380</b>	Auto-Zero, 85MHz, TIA, CMOS	1, 2	2.7	5.5	8.8	90	80	0.025	0.03	50	100	110	Y	Out	MSOP, SOIC, SSOP	\$1.95
<b>OPAy381</b>	Precision, 18MHz, TIA, CMOS	1, 2	2.7	5.5	1	18	12	0.025	0.03	50	100	110	Y	Out	MSOP, SON	\$1.45
OPA177	Precision, Bipolar	1	6	36	2	0.6	0.3	0.025	0.1	1500	130	7.5	N	N	SOIC, PDIP	\$0.80
OPAy227	Low Noise, Bipolar	1, 2, 4	5	36	3.8	8	2.3	0.075	0.1	10000	120	3	N	N	SOIC, PDIP	\$1.10
OPAy228	High CMRR, High GBW, Bipolar	1, 2, 4	5	36	3.8	33	10	0.075	0.1	10000	120	3	N	N	SOIC, PDIP	\$1.10
OPAy234	Low Power, Wide Supply, Bipolar	1, 2, 4	2.7	36	0.3	0.35	0.2	0.1	0.5	25000	96	25	N	N	MSOP, SOIC	\$1.05
TLE2027	Wide Supply, Low Noise, Bipolar	1	8	38	5.3	13	2.8	0.1	0.4	90000	100	2.5	N	N	SOIC, PDIP	\$0.90
OPA637	Low Noise, Difet™	1	9	36	7.5	80	135	0.1	0.4	1	106	5.2	N	N	SOIC	\$12.25
OPA627	Ultra-Low THD+N, Difet	1	9	36	7.5	16	55	0.1	0.4	1	106	5.2	N	N	PDIP, SOIC	\$12.25
OPAy336	$\mu$ Power, CMOS	1, 2, 4	2.3	5.5	0.032	0.1	0.03	0.125	1.5	10	80	40	Y	Out	SOT23, SOIC	\$0.40
<b>OPAy727/8</b>	e-trim™, Precision CMOS	1, 2	4	12	4.3	20	30	0.15	0.3	100	86	23	N	N	MSOP, SON	\$0.95
OPAy241	$\mu$ Power, Bipolar	1, 2, 4	2.7	36	0.03	0.035	0.01	0.25	0.4	20000	80	45	Y	Out	SOIC, DIP	\$1.15
OPAy251	$\mu$ Power, $\pm$ 15V Bipolar	1, 2, 4	2.7	36	0.038	0.035	0.01	0.25	0.5	20000	100	45	Y	Out	SOIC, DIP	\$1.15
OPA124	Wide Bandwidth, Bipolar	1	10	36	3.5	1.5	1.6	0.25	1	1	100	8	N	N	SOIC	\$3.95
TLE2021A	High-Speed, Low-Power, CMOS	1, 2, 4	4	40	0.3	1.2	0.5	0.6	2	70000	85	17	N	N	SOIC, TSSOP, PDIP	\$0.55
TLC1078	Precision, CMOS	2	1.4	16	0.017	0.085	0.032	0.45	1.1	600	70	68	N	N	SOIC, DIP	\$2.30
TLV2211	Low Power, 10V, CMOS		2.7	10	0.025	0.065	0.025	0.45	0.5	150	70	22	Y	Out	SOT23	\$0.42
OPAy364	1.8V, Zero-Crossover™, SHDN, CMOS	1, 2	1.8	5.5	0.75	7	5	0.5	3	10	74	17	Y	I/O	MSOP, SOIC, SOT23	\$0.60
<b>OPAy365</b>	High-Speed, Zero-Crossover, CMOS	1, 2	2.2	5.5	5	50	25	0.5	1	10	100	5	Y	IN	SOT23, SO-8	\$0.95
OPAy350	Excellent ADC Driver, CMOS	1, 2, 4	2.7	5.5	7.5	38	22	0.5	4	10	76	5	Y	I/O	MSOP, SOIC, PDIP	\$0.85
TLC220	Low Noise, RRO, CMOS	1, 2	4.6	16	1.5	1.8	2.5	0.5	0.5	100	85	8	Y	Out	SOIC, PDIP	\$1.65
OPAy340	Low Power, Wide GBW, CMOS	1, 2, 4	2.7	5.5	0.95	5.5	6	0.5	2.5	10	80	25	Y	I/O	SOT23, SOIC, PDIP	\$0.80
OPA345	Low Power, CMOS	1, 2, 4	2.7	5.5	0.25	4	4	0.5	2.5	10	80	32	Y	I/O	SOT23, SOIC	\$0.55
OPA344	Single Supply, CMOS	1, 2, 4	2.7	5.5	0.25	1	1	0.5	2.5	10	80	32	Y	I/O	SOT23, SOIC	\$0.55
OPAy132	Wide GBW, FET	1, 2, 4	4.5	36	4.8	8	20	0.5	2	50	96	8	N	N	SOIC	\$1.45

\*Suggested resale price in U.S. dollars in quantities of 1,000.

New products are listed in bold red.

## Precision Operational Amplifiers

Low-Noise Operational Amplifiers ( $V_N \leq 10\text{nV}/\sqrt{\text{Hz}}$ )

Device	Description/Technology	Ch.	$V_S$ (V) (min)	$V_S$ (V) (max)	$I_Q$ Per Ch. (mA) (max)	GBW (MHz) (typ)	Slew Rate (V/ $\mu$ s) (typ)	$V_{OS}$ (25°C) (mV) (max)	$V_{OS}$ Drift ( $\mu$ V/°C) (typ)	$I_B$ (pA) (max)	CMRR (dB) (min)	$V_N$ at 1kHz (nV/ $\sqrt{\text{Hz}}$ ) (typ)	Single Supply	Rail- to- Rail	Package(s)	Price*
TLE2027	Wide Supply, Bipolar	1	8	38	5.3	13	2.8	0.1	0.4	90000	100	2.5	N	N	SOIC	\$0.90
OPA227	High Precision, Bipolar	1, 2, 4	5	36	3.8	8	2.3	0.075	0.1	10000	120	3	N	N	SOIC, PDIP	\$1.10
OPA228	High Speed, Precision, Bipolar	1, 2, 4	5	36	3.8	33	10	0.075	0.1	10000	120	3	N	N	SOIC, PDIP	\$1.10
OPAy350	Excellent ADC Driver, CMOS	1, 2, 4	2.7	5.5	7.5	38	22	0.5	4	10	76	5	Y	I/O	MSOP, SOIC, PDIP	\$0.85
<b>OPA365</b>	High-Speed, Zero Crossover™, CMOS	1, 2	2.2	5.5	5	50	25	0.5	1	10	100	5	Y	In	SOT23, S08	\$0.95
OPA637	Precision, Decomp High- Speed Difet™	1	9	36	7.5	80	135	0.1	0.4	1	106	5.2	N	N	SOIC	\$12.25
OPA627	Precision, High-Speed, Difet	1	9	36	7.5	16	55	0.1	0.4	1	106	5.2	N	N	SOIC	\$12.25
OPA177	Low Offset, Bipolar	1	6	36	2	0.6	0.3	0.025	0.1	1500	130	7.5	N	N	SOIC, PDIP	\$0.80
OPAy277	High Precision, Low Power, Bipolar	1, 2, 4	4	36	0.825	1	0.8	0.02	0.1	1000	130	8	N	N	SOIC, PDIP	\$0.85
TLC220x	Precision, Low Power, LinCMOS	1, 2	4.6	16	1.5	1.8	2.5	0.5	0.5	100	85	8	Y	Out	SOIC, PDIP	\$1.65
OPAy132	Wide Bandwidth, FET-Input	1, 2, 4	4.5	36	4.8	8	20	0.5	2	50	96	8	N	N	SOIC	\$1.45
OPA124	Precision, Difet	1	10	36	3.5	1.5	1.6	0.25	1	1	100	8	N	N	SOIC	\$3.95
OPA132	High Speed, FET-Input	1, 2, 4	4.5	36	4.8	8	20	0.5	2	50	96	8	N	N	SOIC	\$1.45
<b>OPAy277/8</b>	e-trim™ Precision CMOS	1	4	12	4.3	25	30	0.15	0.3	100	86	23	N	N	SON, MSOP	\$0.95

\*Suggested resale price in U.S. dollars in quantities of 1,000.

New products are listed in bold red.

## Wide Bandwidth, Precision Operational Amplifiers (GBW &gt; 5MHz)

Device	Description/Technology	Ch.	$V_S$ (V) (min)	$V_S$ (V) (max)	$I_Q$ Per Ch. (mA) (max)	GBW (MHz) (typ)	Slew Rate (V/ $\mu$ s) (typ)	$V_{OS}$ (25°C) (mV) (max)	$V_{OS}$ Drift ( $\mu$ V/°C) (typ)	$I_B$ (pA) (max)	CMRR (dB) (min)	$V_N$ at 1kHz (nV/ $\sqrt{\text{Hz}}$ ) (typ)	Single Supply	Rail- to- Rail	Package(s)	Price*
OPAy340	Low Power, CMOS	1, 2, 4	2.7	5.5	0.95	5.5	6	0.5	2.5	10	80	25	Y	I/O	SOT23, DIP, SOIC	\$0.80
OPAy363/4	1.8V, Zero-Crossover™, CMOS	1, 2, 4	1.8	5.5	0.75	7	5	0.5	3	10	74	17	Y	I/O	SOT, SOIC	\$0.60
OPAy227	Low Noise, Precision, Bipolar	1, 2, 4	5	36	3.8	8	2.3	0.075	0.1	10000	120	3	N	N	SOIC	\$1.10
OPAy132	High Speed, FET	1, 2, 4	4.5	36	4.8	8	20	0.5	2	50	96	8	N	N	SOIC	\$1.45
OPAy227	Low Noise, Bipolar	1, 2, 4	5	36	3.8	8	2.3	0.075	0.1	10000	120	3	N	N	SOIC, PDIP	\$1.10
TLE2027A	Low Noise, Bipolar	1	8	38	5.3	13	2.8	0.025	0.2	90000	11	2.5	N	N	SOIC, PDIP	\$1.25
OPA627	Precision, High Speed, Difet	1	9	36	7.5	16	55	0.1	0.4	1	106	5.2	N	N	SOIC, PDIP	\$12.25
OPA381	Precision TIA, CMOS	1	2.7	5.5	1	18	12	0.025	0.03	50	95	110	Y	Out	MSOP, SON	\$1.45
<b>OPA277/8</b>	Precision, e-trim™, CMOS	1	4	12	4.3	20	30	0.15	0.3	100	86	10	Y	Out	MSOP, SON	\$0.95
OPAy228	Precision, Low Noise, Bipolar	1, 2, 4	5	36	3.8	33	10	0.075	0.1	10000	120	3	N	N	SOIC, PDIP	\$1.10
OPAy350	Single Supply, Rail-to-Rail, CMOS	1, 2, 4	2.7	5.5	7.5	38	22	0.5	4	10	76	5	Y	I/O	MSOP, SOIC, PDIP	\$0.85
<b>OPA365</b>	High-Speed, Zero Crossover, CMOS	1, 2	2.2	5.5	5	50	25	0.5	1	10	100	5	Y	In	SOT23, S08	\$0.95
OPA637	Precision, Decomp, Difet	1			7.5	80	135	0.1	0.4	1	106	5.2	N	N	DIP, SOIC	\$12.25
OPAy380	Precision, Wideband TIA	1, 2	2.7	5.5	1	85	80	0.025	0.1	50	—	5 at 1MHz	Y	Out	MSOP, SOIC, SSOP	\$1.95

\*Suggested resale price in U.S. dollars in quantities of 1,000.

New products are listed in bold red.

## → Precision Operational Amplifiers

### Wide Voltage Range Operational Amplifiers ( $\pm 5V < V_S < \pm 20V$ ) Selection Guide

Device	Description	Ch.	V <sub>S</sub> (V) (min)	V <sub>S</sub> (V) (max)	I <sub>Q</sub> Per Ch. (mA) (max)	GBW (MHz) (typ)	Slew Rate (V/ $\mu$ s) (typ)	V <sub>OS</sub> (25°C) (mV) (max)	V <sub>OS</sub> Drift ( $\mu$ V/°C) (typ)	I <sub>B</sub> (pA) (max)	CMRR (dB) (min)	V <sub>N</sub> at 1kHz (nV/ $\sqrt{Hz}$ ) (typ)	Single Supply	Rail- to- Rail	Package(s)	Price*
OPA124	Low Noise, Precision, Bipolar	1	10	36	7.5	1.5	1.6	0.25	2	1	100	8	N	N	PDIP	\$3.95
OPAy703/4	12V, Low Power, SHDN, CMOS	1, 2, 4	4	12	0.2	1	0.6	0.75	4	10	70	45	Y	I/O	MSOP, SOIC, DIP	\$1.30
OPAy734/5	12V, Auto-Zero Precision, SHDN	1, 2	2.7	12	0.75	1.6	1.5	0.005	0.05	200	115	150	Y	Out	SOT23, SOIC	\$1.25
OPAy743	12V, 7MHz, CMOS	1, 2, 4	3.5	12	1.5	7	10	7	8	10	66	30	Y	I/O	MSOP, SOIC	\$0.95
OPAy725/6	Very Low Noise, SHDN	1, 2	4	12	5.5	20	30	3	4	200	88	23	Y	Out	SOT23, SOIC	\$0.90
<b>OPAy727/8</b>	20MHz, e-trim™ Precision CMOS	1, 2, 4	4	12	4.3	90	30	0.25	0.3	100	86	23	N	N	MSOP, SON	\$0.95
TLV237x	550 $\mu$ A, 3MHz, SHDN	1, 2, 4	2.7	15	0.66	3	2.4	4.5	2	60	57	39	Y	I/O	SOT23, MSOP	\$0.43
TLV238x	Low Power, RRIO, Bipolar	1, 2	2.7	16	0.01	0.16	0.06	6.5	1.1	60	72	90	Y	I/O	SOT, SOIC, PDIP	\$0.60
TLC220x	Precision, Low Noise, Bipolar	1, 2	4.6	16	1.5	1.8	2.5	0.5	0.5	100	85	8	Y	Out	SOIC, PDIP	\$1.65
TLV240x	2.5V, 1 $\mu$ A Amplifier, Bipolar	1, 2, 4	2.5	16	0.00095	0.0055	0.0025	1.2	3	300	63	800	Y	I/O	SOT23, SOIC, PDIP	\$0.65
TLC08x	Low Noise, Wide Bandwidth, Bipolar	1, 2, 4	4.5	16	2.5	10	16	1	1.2	50	100	8.5	N	N	MSOP, SOIC, PDIP	\$0.45
OPA627	Ultra-Low THD+N, Difet™	1	9	36	7.5	16	55	0.1	0.4	1	106	5.2	N	N	PDIP, SOIC	\$12.25
OPA637	Ultra-Low THD+N, G $\geq$ 5, Difet	1	9	36	7.5	80	135	0.1	0.4	1	106	5.2	N	N	PDIP, SOIC	\$12.25
OPAy130	Low Power, FET-Input	1, 2, 4	4.5	36	0.65	1	2	1	2	20	90	16	N	N	SOIC	\$1.40
OPAy131	General Purpose, FET Input	1, 2, 4	9	36	1.75	4	10	0.75	2	50	80	15	N	N	SOIC	\$0.75
OPAy132	Wide Bandwidth, FET-Input	1, 2, 4	4.5	36	4.8	8	20	0.5	2	50	96	8	N	N	SOIC	\$1.45
OPAy137	Low Cost, FET-Input	1, 2, 4	4.5	36	0.27	1	3.5	3	15	100	76	45	N	N	SOT23, SOIC	\$0.60
OPAy227	Precision, Low Noise, Bipolar	1, 2, 4	5	36	3.8	8	2.3	0.075	0.1	10000	120	3	N	N	PDIP, SOIC	\$1.10
OPAy228	Precision, Low Noise, G $\geq$ 5, Bipolar	1, 2, 4	5	36	3.8	33	11	0.075	0.1	10000	120	3	N	N	PDIP, SOIC	\$1.10
OPAy234	Low Power, Precision, Bipolar	1, 2, 4	2.7	36	0.35	0.35	0.2	0.1	0.5	25000	91	25	N	N	MSOP, SOIC	\$1.05
OPAy237	Low Cost, Low Power, Bipolar	1, 2	2.7	36	0.35	1.4	0.5	0.75	2	40000	78	28	N	N	SOT23, SOIC	\$0.55
OPAy241	$\mu$ Power, Precision, Bipolar	1, 2, 4	2.7	36	0.03	0.035	0.01	0.25	0.4	20000	100	45	Y	Out	SOIC, PDIP	\$1.15
OPAy244	$\mu$ Power, Low Cost, Bipolar	1, 2, 4	2.6	36	0.05	0.43	0.1	1.5	4	25000	84	22	N	N	SOT23, SOIC, PDIP	\$0.55
OPAy251	$\mu$ Power, Precision, Bipolar	1, 2, 4	2.7	36	0.038	0.035	0.01	0.25	0.5	20000	100	45	Y	Out	PDIP, SOIC	\$1.15
OPAy277	High Precision, Low Power, Bipolar	1, 2, 4	4	36	0.825	1	0.8	0.02	0.1	1000	130	8	N	N	SON, SOIC	\$0.85
TLE2027	Precision, Low Noise, Bipolar	1	8	38	5.3	13	2.8	0.1	0.4	90000	100	2.5	N	N	SOIC, PDIP	\$0.90
TLE202x	Low Power, FET Input	1, 2, 4	4	40	0.3	1.2	0.5	0.6	2	70000	85	17	N	N	SOIC, TSSOP, PDIP	\$0.45

### Low Input Bias Current Operational Amplifiers (I<sub>B2</sub> 10pA)

Device	Description/Technology	Ch.	V <sub>S</sub> (V) (min)	V <sub>S</sub> (V) (max)	I <sub>Q</sub> Per Ch. (mA) (max)	GBW (MHz) (typ)	Slew Rate (V/ $\mu$ s) (typ)	V <sub>OS</sub> (25°C) (mV) (max)	V <sub>OS</sub> Drift ( $\mu$ V/°C) (typ)	I <sub>B</sub> (pA) (max)	CMRR (dB) (min)	V <sub>N</sub> at 1kHz (nV/ $\sqrt{Hz}$ ) (typ)	Single Supply	Rail- to- Rail	Package(s)	Price*
OPA124	Low Noise, Precision	1	10	36	7.5	1.5	1.6	0.25	2	1	100	8	N	N	PDIP	\$3.95
OPA627	Ultra-Low THD+N, Difet™	1	9	36	7.5	16	55	0.1	0.4	1	106	5.2	N	N	PDIP, SOIC	\$12.25
OPA637	Decompensated OPA627, G $\geq$ 5	1	9	36	7.5	80	135	0.1	0.4	1	106	5.2	N	N	PDIP, SOIC	\$12.25
<b>OPA379</b>	1.8V, Ultra-Low Power, CMOS	1, 2, 4	1.8	5.5	0.0045	0.1	0.03	1.5	2.7	50	100	100	Y	I/O	SC-70, SOT-23, MSOP	\$0.75
OPAy336	SS, $\mu$ Power CMOS Amp	1, 2, 4	2.3	5.5	0.032	0.1	0.03	0.125	1.5	10	80	40	Y	Out	SOT23, SOIC	\$0.40
OPAy340	CMOS, Wide Bandwidth	1, 2, 4	2.7	5.5	0.95	5.5	6	0.5	2.5	10	80	25	Y	I/O	MSOP, SOIC, SOT23, TSSOP	\$0.80
OPAy350	Excellent ADC Driver, Low Noise Good AC and DC Performance	1, 2, 4	2.7	5.5	7.5	38	22	0.5	4	10	76	5	Y	I/O	PDIP, MSOP, SOIC	\$0.85
OPA344	Low Power, RRIO, SS	1, 2, 4	2.7	5.5	0.25	1	1	0.5	2.5	10	80	32	Y	I/O	MSOP, DIP, SOIC	\$0.55
OPA363	1.8V, RRIO, High CMRR	1, 2	2.7	5.5	0.75	7	5	0.5	3	10	74	17	Y	I/O	MSOP, SOIC, SOT23	\$0.60
<b>OPAy365</b>	High-Speed, Zero-Crossover™, CMOS	1, 2	2.2	5.5	5	50	25	0.5	1	10	100	5	Y	IN	SOT23, SO-8	\$0.95
<b>OPAy380</b>	Precision, 80MHz, TIA	1, 2	2.7	5.5	1	90	80	0.025	0.1	50	100	5 at 1MHz	Y	Out	MSOP, SOIC, SSOP	\$1.95
<b>OPAy381</b>	Precision, 18MHz TIA	1, 2	2.7	5.5	1	18	12	0.025	0.1	50	1100	5 at 1MHz	Y	Out	MSOP, DFN	\$1.45
OPAy132	Wide Bandwidth, FET-Input	1, 2, 4	4.5	36	4.8	8	20	0.5	2	50	96	8	N	N	SOIC	\$1.45
OPAy735	12V, AutoZero, Precision Amp	1, 2	2.7	12	0.75	2	1.5	0.005	0.1	100	115	110	Y	Out	SOT23, SOIC	\$1.25
OPAy734	12V, Precision, SHDN	1, 2	2.7	12	0.75	2	1.5	0.005	0.1	100	115	110	Y	Out	SOT23, SOIC	\$1.25
TLC220x	Precision, Low Noise	1, 2	4.6	16	1.5	1.8	2.5	0.5	0.5	100	85	8	Y	Out	PDIP, SOIC	\$1.65
<b>OPA727/8</b>	20MHz e-trim™ Precision CMOS	1, 2, 4	4	12	4.3	20	30	0.15	0.3	100	86	23	N	N	MSOP, SON	\$0.95

\*Suggested resale price in U.S. dollars in quantities of 1,000.

New products are listed in bold red.



## Precision Operational Amplifiers

Single-Supply Operational Amplifiers ( $V_S(\min) \leq 2.7V$ )

Device	Description/Technology	Ch.	$V_S$ (V) (min)	$V_S$ (V) (max)	$I_O$ Per Ch. (mA) (max)	GBW (MHz) (typ)	Slew Rate (V/ $\mu$ s) (typ)	$V_{OS}$ (25°C) (mV) (max)	Offset Drift ( $\mu$ V/°C) (typ)	$I_B$ (pA) (max)	CMRR (dB) (min)	$V_N$ at 1kHz (nV/ $\sqrt$ Hz) (typ)	Rail- to- Rail	Package(s)	Price*
OPA349	1 $\mu$ A, Rail-to-Rail, CMOS	1, 2	1.8	5.5	0.002	0.07	0.02	10	10	15	52	—	I/O	SC70, SOT23, SOIC	\$0.75
OPAy363/4	High CMR,RRIO SHDN, CMOS	1, 2, 4	1.8	5.5	0.75	7	5	0.5	3	10	74	25	I/O	SOT23, SOIC	\$0.60
<b>OPA379</b>	1.8V, Ultra-Low Power, Low Offset, CMOS	1, 2, 4	1.8	5.5	0.0045	.09	0.03	1.5	2.7	50	100	80	I/O	SC70, SOT23, SOIC	\$0.75
TLV1078	Single 1.8V RRIO, 8MHz, w/SHDN, CMOS	1, 2, 4	1.4	1.6	0.017	0.085	0.032	0.45	111	800	50	68	0	SOT23, SOIC	\$2.30
<b>OPA333</b>	$\mu$ Power, Zero-Drift, CMOS	1, 2	1.8	5.5	0.025	0.35	0.16	0.01	0.05	200	106	130	I/O	SC70, SOT23, SOIC	\$0.95
OPA348	1MHz, 45 $\mu$ A, RRIO, CMOS	1, 2, 4	2.1	5.5	0.065	1	0.5	5	2	10	70	35	I/O	SC70, SOT23, SOIC	\$0.45
<b>OPAy365</b>	High-Speed, Zero-Crossover™, CMOS	1, 2	2.2	5.5	5	50	25	0.5	1	10	100	5	IN	SOT23, SO8	\$0.95
OPA336	$\mu$ Power, CMOS	1, 2, 4	2.3	5.5	0.032	0.1	0.03	0.125	1.5	10	80	40	Out	SOT23, SOIC	\$0.40
OPA347	Low Power, SC70, CMOS	1, 2, 4	2.3	5.5	0.034	0.35	0.17	6	2	10	70	60	I/O	SC70, SOT23, DIP, SOIC	\$0.48
OPA343	General Purpose, CMOS	1, 2, 4	2.5	5.5	1.25	5.5	6	8	3	10	74	25	I/O	SOT23, SOIC	\$0.60
TLV2770	Single 2.7V High Slew Rate, R/R Output, SHDN, CMOS	1, 2, 4	2.5	5.5	2	4.8	9	2.5	2	100	70	21	Out	MSOP, SOIC, DIP	\$0.70
OPA244	$\mu$ Power, Single-Supply, MicroAmplifier™ Series, Bipolar	1, 2, 4	2.6	36	0.05	0.43	0.1	1.5	4	25000	84	22	In	SOT23, SOIC, DIP	\$0.55
OPA237	Single-Supply, MicroAmplifier Series, Bipolar	1, 2, 4	2.7	36	0.35	1.4	0.5	0.75	2	40000	78	28	In	SOT23, SOIC	\$0.55
OPA241	Single-Supply, $\mu$ Power, Bipolar	1, 2, 4	2.7	36	0.03	0.035	0.01	0.25	0.4	20000	80	45	Out	SOIC, DIP	\$1.15
OPA300/1	High Speed, Low Noise, SS, CMOS	1	2.7	5.5	12	150	80	5	2.5	5	66	3	Out	SOT23, SOIC	\$1.25
OPA334/5	Zero Offset 0.05 $\mu$ V/°C (max), SHDN, CMOS	1, 2	2.7	5.5	0.35	2	1.6	0.005	0.02	200	110	50	Out	SOT23	\$1.00
OPA337	120dB $A_{OL}$ , FET input	1, 2	2.7	5.5	1	3	1.2	3	2	10	74	26	Out	SOT23, MSOP, SOIC, DIP	\$0.43
OPA338	Good Speed/Power, $G \geq 5$ , CMOS	1, 2	2.7	5.5	1	12.5	4.6	3	2	10	74	26	Out	SOT23, SOIC	\$0.43
OPA340	5.5MHz, CMOS	1, 2, 4	2.7	5.5	0.95	5.5	6	0.5	2.5	10	80	25	I/O	SOT23, SOIC, DIP	\$0.80
OPA341/2	Low Cost, Low Power, CMOS	1, 2, 4	2.7	5.5	1	5.5	6	6	2	10	74	32	I/O	SOT23, SOIC	\$0.75
OPA344	Low Power, Low Offset, CMOS	1, 2, 4	2.7	5.5	0.25	1	1	0.5	2.5	10	80	32	I/O	SOT23, SOIC, DIP	\$0.55
OPA345	Low Power, Single-Supply, R/R, MicroAmplifier Series, CMOS	1, 2, 4	2.7	5.5	0.25	4	4	0.5	2.5	10	80	32	I/O	SOT23, SOIC	\$0.55
OPA350	High-Speed, Single-Supply, R/R, CMOS	1, 2, 4	2.7	5.5	7.5	38	22	0.5	4	10	76	5	I/O	MSOP,SOIC, DIP	\$0.85
OPA353	Good ADC Driver, Low THD+N, CMOS	1, 2, 4	2.7	5.5	8	44	22	8	5	10	76	5	I/O	SOT23, SOIC	\$1.00
<b>OPA373/4</b>	6.5MHz, 585 $\mu$ A, Shutdown, CMOS	1	2.7	5.5	0.75	6.5	5	5	3	10	80	30	I/O	SOT23, SOIC	\$0.36
<b>THS4281</b>	High Speed, Low Power	1	2.7	15	1	40	35	3.5	7	10	92	12.5	I/O	SOT23, MSOP, SOIC	\$0.95

\*Suggested resale price in U.S. dollars in quantities of 1,000.

New products are listed in bold red.



## High-Speed Amplifiers

TI develops high-speed signal conditioning products using state-of-the-art processes that give leading-edge performance. Used in high-speed signal chains and analog-to-digital drive circuits, high-speed amps are broadly defined as any amplifier having at least 50MHz of bandwidth and at least 100V/ $\mu$ s slew rate. High-speed amps from TI come in several different types and supply voltage options.

### Design Considerations

**Voltage-feedback type**—the most commonly used amp and the basic building block of most analog signal chains such as gain blocks, filtering, level shifting, buffering, etc. Most voltage-feedback amps are unity-gain stable, though some are decompensated to provide wider bandwidth, faster slew rate and lower noise.

**Current-feedback type**—most commonly seen in video or DSL line driver applications, or designs where extremely fast slew rate is needed.

**Fully differential amplifier (FDA)**—the fully differential input and output topology has the primary benefit of reducing even order harmonics, thereby reducing total harmonic distortion. The FDA also rejects common-mode components in the signal and provides a larger output swing to the load relative to single-ended amplifiers. Fully differential amplifiers are well-suited to driving analog-to-digital converters. A  $V_{COM}$  pin sets the output common-mode voltage required by newer, single-supply, ADCs.

**FET-Input (or CMOS) amplifiers**—have higher input impedance than typical bipolar amps and are more useful to interfacing to high impedance sources, such as photodiodes in transimpedance circuits.

**Video amplifiers**—can be used in a number of different ways, but generally are in the signal path for amplifying, buffering, filtering or driving video lines. The specifications of most interest are differential gain and differential phase. Current-feedback amps are typically used in video applications, because of their combination of high slew rate and excellent output drive at low quiescent power.

**Fixed and variable gain**—these amps have either a fixed gain, or a variable gain that can be set either digitally with a few control pins, or linearly with a control voltage. Fixed-gain amplifiers are fixed internally with gain setting resistors. Variable gain amplifiers can have different gain ranges, and can also be differential input and/or output.

**Packaging**—high-speed amplifiers typically come in surface-mount packages, because parasitics of DIP packages can limit performance. Industry standard surface-mount packages (SOIC, MSOP, TSSOP, QFN and SOT23) handle the highest speed requirements. For bandwidths approaching 1GHz and higher, the QFN package decreases inductance and capacitance.

**Evaluation boards**—high-speed amps have an associated fully populated Evaluation Module (EVM) or an unpopulated printed circuit board (PCB). EVMs are a very important part of high-speed amplifier evaluation, since layout is critical to design success. To make layout simple, Gerber files for the EVMs are available. See page 101 for more information.

Voltage Feedback			Current Feedback
<b>High-Speed &lt; 500MHz (GBW Product)</b> — THS4001 — THS4011/4012 — THS4051/4052 — THS4081/4082 — THS4041/4042 — OPA820/OPA4820 — OPA2613 — OPA2614 — OPA842 — OPA2652 — OPA2822 — THS4271 — OPA690/2690/3690 — OPAy890	<b>FET or CMOS Input</b> — OPA656 — OPA657 (G > 7) — OPA355/2355/3355 — OPA356/2356 — OPA354/2354/4354 — OPA357/2357 — OPA358/OPA360/OPA361 — OPA300/OPA2300 — OPA301/OPA2301 — THS4631 — OPAy380/OPA2380	<b>Low Noise <math>\leq 3nV/\sqrt{Hz}</math></b> — THS4031/4032 (G $\geq 2$ ) — OPA2822 — THS4130/4131 — THS4271 — OPA300/OPA301 — OPA820/OPA4820 — OPA842 — OPA843 (G > 3) — OPA846/OPA2846 (G > 7) — OPA847 (G > 12) — OPA358 — OPA820/OPA4820	<b>General Purpose +5V to <math>\pm 5V</math> Operational</b> — OPA683/2683 — OPA684/2684/3684/4684 — OPA691/2691/3691 — OPA692/3692 (G = 2 or $\pm 1$ ) — OPA2677 — THS3201/02 — OPA694/OPA2694
<b>Fully Differential</b> — THS4120/4121 — THS4130/4131 — THS4140/4141 — THS4500/4501 — THS4502/4503 — THS4509 — THS4508 — THS4511 — THS4513 — THS4520	<b>Low Voltage <math>\leq 3.3V</math></b> — THS4120/21 — OPA355/2355/3355 — OPA356/2356 — THS4222/4226 — OPA354/2354/4354 — OPA357/2357 — OPA300/OPA2300 — OPA301/OPA2301 — OPA358/OPA360/OPA361 — OPA830/OPA2830 — OPA832/OPA2832	<b>Variable and Fixed Gain</b> — THS7530 — VCA2612/2613/2614/2616/2618 — VCA810 — VCA8613/VCA8617 — VCA2615/VCA2617 — OPA860 — OPA861 — BUF602 — BUF634 — OPA615	<b>General Purpose <math>\pm 5V</math> to <math>\pm 15V</math> Operational</b> — THS3112/15 — THS3122/25 — THS3110/11 — THS3120/1 — THS3091/95 — THS3092/96 — THS6184
<b>Very High-Speed &gt; 500MHz (GBW Products)</b> — OPA843 — OPA847 — OPA846/OPA2846 — THS4271 — THS4302	<b>Rail-to-Rail Input or Output</b> — OPA355/2355/3355 — OPA356/2356 — THS4222/4226 — OPA354/2354/4354 — OPA357/2357 — OPA358/OPA360 — OPA830/OPA2830/OPA4830 — OPA832/OPA2832	<b>Voltage Limiting Output</b> — OPA698 — OPA699 (G $\geq 4$ )	<b>Very High-Speed &gt; 500MHz</b> — OPA695 — THS3201/THS3202 — OPA694/OPA2694

High-speed amplifiers selection tree.

Preview devices appear in BLUE.  
New devices appear in RED.



## Wideband, Low-Noise, Low-Distortion, Fully Differential Amplifier

### THS4511

Get samples, datasheets, EVMs and app reports at: [www.ti.com/sc/device/THS4511](http://www.ti.com/sc/device/THS4511)

#### Key Features

- Fully differential architecture
- Minimum gain = 0dB
- Small signal bandwidth: 1600MHz (G = 0dB)
- Slew rate: 4900V/ $\mu$ s (2V step, G = 0dB)
- Settling time: 3.3ns (2V step, G = 0dB,  $R_L = 100\Omega$ , 0.1%)
- $HD_2$ : -72dBc at 100MHz (2Vpp, G = 0dB,  $R_L = 200\Omega$ )
- $HD_3$ : -87dBc at 100MHz (2Vpp, G = 0dB,  $R_L = 200\Omega$ )
- Input voltage noise: 2nV/ $\sqrt{Hz}$  (f > 10MHz)
- Output common-mode control
- +5V single-ended power supply
- Power-down capability: 0.65mA
- Offered in a QFN-16 package and characterized for operation over the full industrial temperature range of -40°C to +85°C.

The THS4511 is a high-performance, fully differential operational amplifier that has been optimized for use in 5V, single-supply data acquisition systems. Robust input supports signals below the negative rail.

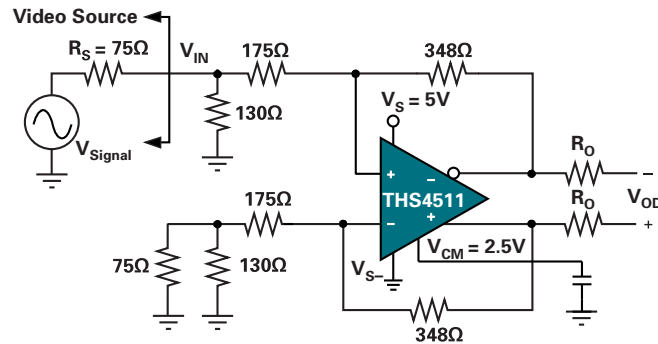

THS4511 in single-ended to differential video buffer application.

#### Applications

- 5V data acquisition systems
- High linearity ADC amplifier
- Medical imaging
- Wireless communication
- Test and measurement

## Dual-Port, Low-Power, Differential xDSL Line Driver Amplifier

### THS6184

Get samples, datasheets, EVMs and app reports at: [www.ti.com/sc/device/THS6184](http://www.ti.com/sc/device/THS6184)

#### Key Features

- Trimmed low power consumption:
  - 4.2/3.2/2.15mA/amp quiescent current
- Very low noise:
  - Voltage noise: 2.9nV/ $\sqrt{Hz}$
  - Inverting current noise: 5.7pA/ $\sqrt{Hz}$
- Low MTPR of -74dB for ADSL
- Low distortion: -83dB at 1MHz, 100 $\Omega$  diff.
- High output current: >410mA into 25 $\Omega$
- Wide power supply voltage: 5V to 33V
- Wide bandwidth: 45MHz at gain = 5V/V
- Packaging: QFN-24 and TSSOP PowerPAD™

High linearity with low power, low noise, high output current and high density make the THS6184 ideal for xDSL systems that must achieve high densities in ADSL central office rack applications by combining two ports, or four amplifiers into one package. The wide output swing of 44Vpp differentially with  $\pm 12$ V power supplies coupled with over 410mA current drive allow for wide dynamic headroom, keeping distortion minimized.

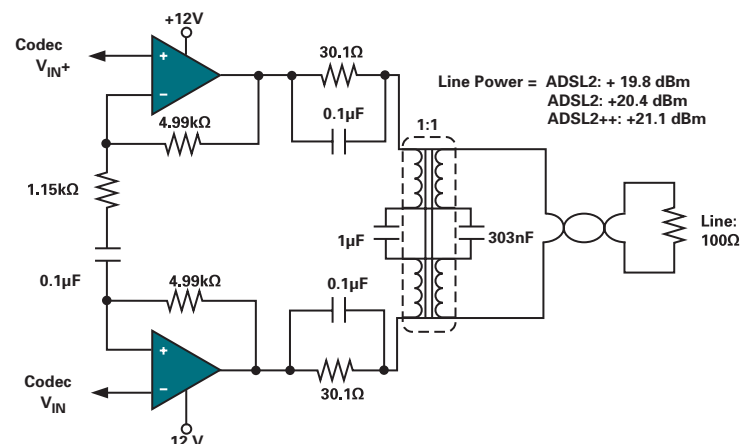

ADSL line driver utilizing one part of the THS6184.



High-Speed Amplifiers

High-Speed Amplifiers Selection Guide

Device	Ch.	SHDN	Supply Voltage (V)	A <sub>CL</sub> (min)	BW at A <sub>CL</sub> (MHz)	BW G = ±2 (MHz)	GBW Product (MHz)	Slew Rate (V/μs)	Settling Time 0.1% (ns)	THD 2V <sub>pp</sub> G = 1 1MHz (dB)	Distortion			V <sub>N</sub> (nV/√Hz) (typ)	V <sub>OS</sub> (mV) (max)	I <sub>B</sub> (μA) (max)	I <sub>O</sub> Per Ch. (mA) (typ)	I <sub>OUT</sub> (mA) (typ)	Package(s)	Price*
											1V <sub>pp</sub> , G = 2, 5MHz	HD <sub>2</sub> (dBc) (typ)	HD <sub>3</sub> (dBc) (typ)							
										Gain (%)	Phase (°)									
<b>Voltage Feedback (Sorted by Ascending Gain Bandwidth Product)</b>																				
THS4051/52	1, 2	N	±5, ±15	1	70	38	50	240	60	-82	-66	-79	0.01	14	10	6	8.5	100	SOIC, MSOP PowerPAD™	\$0.95
THS4011/12	1, 2	N	±5, ±15	1	290	50	100	310	37	-80	-65	-80	0.006	7.5	6	6	7.8	110	SOIC, MSOP PowerPAD	\$1.45
THS4081/82	1, 2	N	±5, ±15	1	175	70	100	230	43	-64	-67	-52	0.01	10	7	6	3.4	85	SOIC, MSOP PowerPAD	\$1.20
OPA4354/57	1, 2, 4	Y	2.5 to 5.5	1	250	90	100	150	30	—	-75	-83	0.02	6.5	8	50pA	4.9	100	SOT23, SOIC PowerPAD	\$0.75
OPA490	1, 2	N	5, ±5	1	275	92	120	400	10	-88	-82	-90	0.05	8	6	1.6	2.25	40	MSOP, SOIC	\$0.80
OPA4830	1, 2, 4	N	+3, +5, ±5	1	310	120	110	600	42	-82	-71	-77	0.07	9.5	1.5	10	4.25	150	SOT23, SOIC	\$0.75
THS4221/22	1, 2	N	3, 5, ±5, 15	1	230	100	120	975	25	-100	-79	-92	0.007	13	10	3	14	100	SOIC, MSOP PowerPAD	\$1.90
OPA2613	2	N	5, ±6	1	230	110	125	70	40	-94	—	—	—	1.8	1	10	6	350	SOIC, SOIC PowerPAD	\$1.55
OPA4300/301	1	Y	2.7 to 5.5	1	400	80	150	80	30	—	-74	-78	0.01	3	5	0.5	12	40	SOT23, SOIC	\$1.25
OPA842	1	N	±5	1	350	150	200	400	15	-107	-104	-104	0.003	2.6	1.2	35	20.2	100	SOT23, SOIC	\$1.55
OPA2652	2	N	±5	1	700	200	200	335	—	-100	-76	-66	0.05	8	7	15	5.5	140	SOT23, SOIC	\$1.15
OPA4355/356	1, 2, 3	Y	2.5 to 5.5	1	450	100	200	300	30	—	-81	-93	0.02	0.05	9	50pA	8.3	60	SOT23, SOIC, MSOP, TSSOP	\$4.90
OPA4356	1, 2	N	2.5 to 5.5	1	450	100	200	300	30	—	-81	-93	0.02	0.05	9	50pA	8.3	60	SOT23, SOIC, MSOP	\$0.85
THS4631	1	N	±15	1	325	105	210	1000	40	-74	-76	-94	—	7	0.26	100pA	11.5	98	SOIC, SOIC & MSOP PowerPAD	\$3.75
THS4031/32	1, 2	N	±5, ±15	1	275	100	220	100	60	-72	-77	-67	0.015	1.6	2	6	8.5	90	SOIC, MSOP PowerPAD	\$1.65
OPA2822	2	N	5, ±5	1	400	200	220	170	32	-96	-81	-91	0.02	2	1.2	12	4.8	150	SOIC, MSOP	\$1.35
OPA656	1	N	±5	1	400	185	240	290	8	-92	-80	-89	0.01	6	2	20pA	25	60	SOT23, SOIC	\$3.35
OPA688	1	N	5, ±5	1	450	215	250	1100	—	-93	-82	-88	0.012	5.6	5	10	15.5	120	SOIC	\$1.90
OPA4820	1, 4	N	5 to ±5	1	800	240	280	240	18	-84	-90	-110	0.01	7.5	0.75	17	5.6	110	SOIC, SOIC PowerPAD	\$0.90
OPA2614	2	N	5, ±6	2	180	180	290	145	35	-85	-72	-81	—	1.8	1	14.5	6.5	350	SOIC, SOIC PowerPAD	\$1.55
OPA4890	1, 2, 3	Y	5, ±5	1	500	220	300	1800	8	-91	-78	-78	0.06	5.5	4	8	5.5	190	SOT23, SOIC, SSOP	\$1.35
THS4271/75	1	Y	5, ±5, 15	1	1400	390	400	1000	25	-110	-100	-94	0.007	3	10	15	22	160	SOIC, MSOP PowerPAD	\$2.25
OPA843	1	N	±5	3	500	—	800	1000	7.5	-105	—	—	0.001	2	1.2	35	20.2	100	SOT23, SOIC	\$1.60
THS4304	1	N	3 to ±5	1	3000	1000	870	1000	5	-92	-92	-75	—	2.4	4	6	18	100	SOT23, SOIC, MSOP	\$1.75
OPA699	1	N	5, ±5	4	260	—	1000	1400	7	—	—	—	0.012	4.1	5	10	15.5	120	SOIC	\$1.95
OPA657	1	N	±5	7	350	—	1600	700	10	—	—	—	—	4.8	1.8	20pA	14	70	SOT23, SOIC	\$3.80
OPA4846	1, 2	N	±5	7	500	—	1750	625	10	—	—	—	0.02	1.2	0.6	19	12.6	80	SOT23, SOIC	\$1.70
OPA847	1	Y	±5	12	600	—	3800	950	10	—	—	—	—	0.85	0.5	39	18.1	75	SOT23, SOIC	\$2.00
<b>Current Feedback (Sorted by Ascending Gain of ±2 Bandwidth)</b>																				
THS3110/11	1	Y	±5, ±15	1	100	90	—	1300	27	-78	-60	-61	0.01	3	6	20	4.8	260	SOIC, MSOP PowerPAD	\$1.30
THS3112/15	2	Y	±5, ±15	1	110	110	—	1550	63	-78	-77	-80	0.01	2.2	8	23	4.9	270	SOIC, SOIC PowerPAD	\$2.00
THS3120/1	1	Y	±5, ±15	1	130	120	—	1500	11	-53	-65	-53	0.007	2.5	6	3	7	475	SOIC, MSOP PowerPAD	\$1.85
THS3122/25	2	Y	±5, ±15	1	160	128	—	1550	64	-78	-70	-77	0.01	2.2	6	23	8.4	440	SOIC, SOIC PowerPAD	\$2.95
OPA4683	1, 2	Y	5, ±5	1	200	150	—	540	—	-84	-70	-85	0.06	4.4	3.5	4	0.94	110	SOT23, SOIC	\$1.20
OPA4684	1, 2, 3, 4	Y	5, ±5	1	210	160	—	820	—	-77	-73	-77	0.04	3.7	3.5	35	1.7	120	SOT23, SOIC, TSSOP	\$1.35
OPA2677	2	N	5, ±6	1	220	200	—	2000	—	-87	-75	-85	0.03	2	4.54	30	9	500	SOIC, SOIC PowerPAD, QFN	\$1.65
THS3091/5	1	Y	±5, ±15	1	235	210	—	5000	42	-72	-79	-88	0.013	2	3	15	9.5	280	SOIC, SOIC PowerPAD	\$2.45

New products are listed in bold red. Preview products are listed in bold blue.

\*Suggested resale price in U.S. dollars in quantities of 1,000.



High-Speed Amplifiers



High-Speed Amplifiers Selection Guide

Device	Ch.	SHDN	Supply Voltage (V)	A <sub>CL</sub> (min)	BW at A <sub>CL</sub> (MHz)	BW G = +2 (MHz)	Product BW (MHz)	Slew Rate (V/μs)	Settling Time 0.1% (ns)	Distortion			V <sub>n</sub> (nV/√Hz) (typ)	V <sub>os</sub> (mV) (max)	I <sub>B</sub> (μA) (max)	I <sub>Q</sub> Per Ch. (mA) (typ)	I <sub>OUT</sub> (mA) (typ)	Package(s)	Price*		
										THD 2Vpp G = 1 1MHz (dB) (typ)	HD <sub>2</sub> (dBc) (typ)	HD <sub>3</sub> (dBc) (typ)									
<b>Current Feedback (Sorted by Ascending Gain of +2 Bandwidth) (Continued)</b>																					
<b>THS3092/6</b>	2	Y	+5, ±15	1	235	210	—	5000	42	-72	-79	-88	0.013	2	4	15	9.5	280	SOIC, SOIC PowerPAD™	\$3.90	
OPA2674	2	Y	5, ±6	1	250	225	—	2000	—	-87	-73	-82	0.03	2	4.5	30	9	500	SOIC, SOIC PowerPAD	\$1.70	
OPA4691	1, 2, 3	Y	5, ±5	1	280	225	—	2100	8	-93	-77	-79	0.07	1.7	2.5	35	5.1	190	SOT-23, SOIC, SSOP	\$1.45	
<b>OPA4694</b>	1, 2	N	+5	1	1500	690	—	1700	13	—	-92	-93	0.03	2.1	4.1	18	5.8	80	SOT-23, SOIC	\$1.25	
THS3201/02	1, 2	N	+5, ±7.5	1	1800	850	—	6200	20	-85	-85	-95	0.006	3	3	13	14	115	MSOP, SOT23, SOIC	\$1.60	
OPA695	1	Y	5, ±5	1	1700	1400	—	4300	—	-86	-88	-95	0.04	1.8	3	30	12.9	120	SOT23, SOIC	\$1.35	
<b>Fully Differential Amplifiers (Sorted by Ascending Gain Bandwidth Product)</b>																					
THS4130/31	1	Y	5, ±5, ±15	1	150	90	180	52	78	-97	-60	-75	—	1.3	2	6	12.3	85	SOIC, MSOP PowerPAD	\$2.80	
THS4502/03	1	Y	5, ±5	1	370	175	280	2800	6.3	-100	-83	-97	—	6	7	4.6	23	120	SOIC, MSOP PowerPAD	\$4.00	
<b>THS4520</b>	1	Y	3 to 5	1	550	430	1400	570	6.3	-100	—	—	—	1.6	—	—	14	110	QFN	\$2.45	
<b>THS4511</b>	1	Y	3, 5	1	1600	1400	2000	4900	3.3	-97	—	—	—	2	5.2	15.5	39.2	61	QFN	\$3.45	
<b>THS4513</b>	1	Y	3, 5	1	1600	1400	2000	5100	16	-97	—	—	—	2.2	5.2	13	37.7	96	QFN	\$3.25	
<b>THS4508</b>	1	Y	3, 5	2	2000	2000	3000	6400	2	-98	—	—	—	2.3	5	15.5	39.2	61	QFN	\$3.95	
<b>THS4509</b>	1	Y	3, 5	2	2000	2000	3000	6600	2	-98	—	—	—	1.9	5	13	37.7	96	QFN	\$3.75	
<b>Fixed and Variable Gain (Sorted by Ascending A<sub>CL</sub> Bandwidth)</b>																					
<b>VCA810</b>	1	N	+5	0.01	30	30	—	350	30	-35	-71	-35	—	2.4	0.25	10	20	60	SOIC	\$5.75	
OPA4832	1, 2	N	2.8 to ±5	1	90	80	—	350	45	-64	-66	-73	0.1	0.16	7	10	4.25	120	SOT23, SOIC	\$0.70	
BUF634	1	N	5, ±5, ±15	1	180	—	—	2000	200	—	—	—	—	4	100	20	15	250	SOIC	\$3.05	
OPA4692	1, 3	Y	5, ±5	1	280	225	—	2000	8	-93	-70	-74	0.07	1.7	2.5	35	5.1	190	SOT23, SOIC, SSOP	\$1.15	
THS7530	1	Y	5	4	300	—	—	1750	—	-51	-54	-50	—	1.27	—	30	35	20	TSSOP PowerPAD	\$3.85	
<b>BUF602</b>	1	N	3.3, 5, ±5	1	1200	—	—	8000	—	—	—	—	—	5.1	30	7	5.8	60	SOT23, SOIC	\$0.85	
OPA693	1	Y	5, ±5	1	1400	700	—	2500	12	-87	-74	-87	0.03	1.8	2	35	13	120	SOT23, SOIC	\$1.30	
THS4303	1	Y	3, 5	10	1800	—	—	5500	—	—	—	—	—	2.5	4.25	10	34	180	MSOP PowerPAD	\$2.10	
THS4302	1	Y	3, 5	5	2400	—	—	5500	—	—	—	—	—	2.8	4.25	10	37	180	MSOP PowerPAD	\$2.10	
<b>JFET-input and CMOS Amplifiers (Sorted by Ascending Gain Bandwidth Product)</b>																					
<b>OPA358</b>	1	Y	2.7 to 3.3	1	100	10	80	55	35	—	—	—	0.3	0.7	6	50pA	7.5	50	SC70	\$0.45	
<b>OPA4380</b>	1, 2	N	2.7 to 5.5	1	100	10	90	80	—	—	—	—	—	67	0.025	50pA	7.5	50	MSOP, SOIC	\$1.95	
OPA4354	1, 2, 4	N	2.5 to 5.5	1	250	90	100	150	30	—	-75	-83	0.02	0.09	8	50pA	4.9	100	SOT23, SOIC PowerPAD	\$0.67	
OPA4357	1, 2	Y	2.5 to 5.5	1	250	90	100	150	30	—	-75	-83	0.02	0.09	8	50pA	4.9	100	SOT23, SOIC PowerPAD	\$0.67	
<b>OPA4300/301</b>	1, 2	Y	2.7 to 5.5	1	—	80	150	80	30	—	-74	-78	0.01	0.1	3	5	5pA	12	40	SOT-23, SOIC	\$1.25
OPA4355	1, 2, 3	Y	2.5 to 5.5	1	450	100	200	300	30	—	-81	-93	0.02	0.05	5.8	9	50pA	8.3	60	MSOP	\$0.69
OPA4356	1, 2	N	2.5 to 5.5	1	450	100	200	300	30	—	-81	-93	0.02	0.05	5.8	9	50pA	8.3	60	SOT23, SOIC	\$0.69
<b>THS4631</b>	1	N	+15	1	325	105	210	1000	40	-74	-76	-94	—	7	0.26	100pA	11.5	98	SOP, MSOP, SOIC	\$3.75	
OPA656	1	N	+5	1	400	185	240	290	8	-92	-80	-89	0.01	6	2	2pA	25	60	SOT23, SOIC	\$3.35	
OPA657	1	N	+5	7	350	—	1600	700	10	-83	-73	-100	—	4.8	1.8	2pA	14	70	SOT23, SOIC	\$3.80	

\*Suggested resale price in U.S. dollars in quantities of 1,000.

New products are listed in bold red. Preview products are listed in bold blue.



## High-Speed Amplifiers

### High-Speed Amplifiers Selection Guide

Device	Ch.	SHDN	Supply Voltage (V)	A <sub>CL</sub> (min)	BW at A <sub>CL</sub> (MHz)	BW G = +2 (typ)	GBW Product (MHz)	Slew Rate (V/μs)	Settling Time 0.1% (ns)	Distortion			V <sub>N</sub> (nV/√Hz) (typ)	V <sub>OS</sub> (mV) (max)	I <sub>B</sub> (μA) (max)	I <sub>n</sub> Per Ch. (mA) (typ)	I <sub>OUT</sub> (mA) (typ)	Package(s)	Price*
										THD 2V <sub>pp</sub> G = 1 (dB) (typ)	1V <sub>pp</sub> G = 2, 5MHz (typ)	Differential							
										Gain (%)	Phase (°)								
												HD <sub>2</sub> (dBc) (typ)	HD <sub>3</sub> (dBc) (typ)						
<b>xDSL Drivers and Receivers (Sorted by Ascending Output Current)</b>																			
THS4032	2	N	+5, ±15	1	275	100	220	100	60	-72	-77	-67	1.6	2	6	8.5	90	SOIC, MSOP PowerPAD™	\$2.60
OPA4684	4	N	+5, ±6	1	250	170	—	750	—	-79	-80	-80	3.7	3.5	35	1.7	120	TSSOP, SOIC	\$3.30
OPA2822	2	N	5, ±5	1	400	200	220	170	32	-96	-81	-91	2	1.2	12	4.8	150	SOIC, MSOP	\$1.35
THS16092/93	2	Y	5, ±6	1	100	—	—	600	—	-72	—	—	2.1	16	10	6.7	240	SOIC, SOIC PowerPAD	\$2.15
THS8022	2	N	+5, ±15	1	210	200	—	1900	70	-75	-55	-58	1.7	5	9	7.2	250	TSSOP	\$2.75
OPA2613	2	N	5, ±6	1	230	110	125	70	40	-94	—	—	1.8	1	10	6	350	SOIC, SOIC PowerPAD	\$1.55
OPA2614	2	N	5, ±6	2	180	180	290	145	35	-75	92	110	1.8	1	14.5	6.5	350	SOIC, SOIC PowerPAD	\$1.55
THS8042/43	2	Y	+5, ±15	1	120	95	—	1000	—	-75	-40	-60	2.2	16	12	8.2	350	SOIC, SOIC PowerPAD, TSSOP	\$2.65
THS8184	4	Y	+5, ±16	1	50	—	—	400	—	-83	-83	-61	2.9	15	15	4.2	400	QFN, TSSOP	\$3.75
OPA2674	2	Y	5, ±6	1	260	—	—	2000	—	—	-82	-93	2	2	10	9	500	SOIC	\$1.70
OPA2677	2	N	5, ±6	1	220	200	—	2000	—	-87	-75	-85	2	4.5	30	9	500	SOIC, SOIC PowerPAD	\$1.65
THS8012	2	N	+5, ±15	1	140	120	—	1300	70	-79	-65	-65	1.7	5	9	11.5	500	SOIC PowerPAD, BGA <sup>1</sup>	\$3.75
THS8132	2	Y	+5, ±15	1	80	70	—	300	—	-83	-78	-70	3.5	1	1	6.4	500	QFN TQFP PowerPAD	\$3.95
THS8182	2	Y	+5, ±16	1	100	80	—	450	—	-88	-72	-70	3.2	20	15	11.5	600	QFN, SOIC PowerPAD	\$2.95
<b>Transimpedance Amplifiers (Sorted by Ascending Gain Bandwidth Product)</b>																			
OPA4380	1, 2	N	2.7, 5.0	1	90	45	90	80	2000	—	—	—	5.8	0.025	50pA	6.5	50	MSOP, SOIC	\$1.95
THS4631	1	N	+15	1	325	105	210	1000	40	-74	-76	-94	7	0.26	100pA	11.5	98	SOIC, MSOP & SOIC PowerPAD	\$3.75
OPA656	1	N	+5	1	400	185	240	290	8	-92	-80	-89	6	20pA	25	60	SOT23, SOIC	\$3.35	
OPA657	1	N	+5	7	350	—	1600	700	10	-83	-73	-100	4.8	1.8	20pA	14	70	SOT23, SOIC	\$3.80
OPA846	1, 2	N	+5	7	500	—	1750	625	10	-105	—	—	1.2	0.6	19	12.6	80	SOT23, SOIC	\$1.70
OPA847	1	Y	+5	12	600	—	3800	950	10	-110	—	—	0.85	0.5	39	18.1	75	SOT23, SOIC	\$2.00
<b>Multi-Channel Fixed Gain Preamps</b>																			
MPA4609	4	N	5	190	90	—	—	150	—	—	—	—	0.65	0.2	—	12.5	—	TQFP	\$3.95
<b>Voltage-Limiting Amplifiers</b>																			
OPA698	1	N	5, ±5	1	450	215	250	1100	—	-93	-82	-88	5.6	5	10	15.5	120	SOIC	\$1.90
OPA699	1	N	5, ±5	4	260	—	1000	1400	—	—	—	—	4.1	5	10	15.5	120	SOIC	\$1.95
<b>RF/IF Amplifiers</b>																			
THS9000/1	1	N	3, 5	5.8	500	—	—	—	—	—	—	—	0.6	—	—	Var	—	MicroMLP, SOT23	\$1.05
<b>DC Restoration (Sample/Hold Amplifier)</b>																			
OPA615	1	N	+5	1	710	—	—	2500	—	—	-62	-47	4.6	4	1	13	5	SOIC, MSOP	\$4.25
<b>Filtered Amplifiers</b>																			
THS7303	3	Y	2.7 to 5.5	—	—	9/16/35/190	—	40/75/155/320	—	-59/-62/-58/-60	—	—	—	35	—	6	70	TSSOP	\$1.65
THS7313	3	Y	2.7 to 5.5	—	—	8	—	35	—	-62	—	—	—	35	—	6	70	TSSOP	\$1.20
THS7353	3	Y	2.7 to 5.5	—	—	9/16/35/150	—	40/70/150/300	—	-64/-73/-70/-71	—	—	—	20	—	5.9	70	TSSOP	\$1.65
<b>Transconductance Amplifiers</b>																			
OPA660	1	N	+5	1	470	—	470	3500	—	—	-77	-79	2.4	—	5	11.2	15	SOIC	\$2.25
OPA661	1	N	+5	1	80	—	400	900	—	—	-68	-57	2.4	—	1	5.4	15	SOT23, SOIC	\$0.95

<sup>1</sup>MicroStar Junior™ BGA.

\*Suggested resale price in U.S. dollars in quantities of 1,000.

New products are listed in bold red.  
Preview products are listed in bold blue.

## Video Amplifiers



**Video amplifiers**—can be used in a number of different ways, but generally they are in the signal path for amplifying, buffering, filtering or driving video lines. The specifications of most interest for composite video signals, or CVBS, are differential gain and differential phase. For other video signals, such as YPbPr or RGB, bandwidth, both small signal and large signal, and slew rate are of most importance. Noise and DC accuracy are also considered important in some high-end applications.

The traditional voltage-feedback (VFB) amplifier is widely used, because of its ability to be configured for almost any situation. Many VFB amplifiers have the ability to accept input signals going to the negative rail (or ground), allowing use in many single-supply systems. Additionally, many VFB amplifiers offer rail-to-rail outputs offering the widest dynamic range possible on reduced supplies. Traditional VFB amplifiers (non-RRO) designed for video offer the ability to have very high slew rates, wide bandwidths, low noise, and very good DC characteristics. Current-feedback amps are commonly found in high-end video applications, because of their combination of high slew rate and excellent output drive at low quiescent power.

TI is bringing new technology to the market with the introduction of the THS7303, THS7313 and THS7353. These new three-channel devices are the first to offer full I<sup>2</sup>C programmability of all functions independently for each channel, which provides the designer the flexibility to configure a video system as required or on-the-fly, without the need for hardware upgrades or modifications. The devices are designed with integrated Butterworth filters to provide all the analog signal conditioning required in video applications such as set-top boxes, digital televisions, personal video recorders/DVD readers and portable USB devices. These highly integrated devices provide space savings as a result of the high levels of integration and advanced package technology.

**Portable video**—Successfully designing a high-performance video system into low voltage portable applications requires careful attention to many small details. Portable applications impose very challenging technical requirements beyond those required in typical video applications and demand particular trade-offs in performance, power consumption, printed circuit board space and cost. A DC-coupled solution with integrated gain, low-pass filter, level-shifter and shutdown solves these challenges while maintaining good video performance—and eliminates the need for large, expensive discrete components.

The strong combination of integrated features and optimized design make TI's OPA360 and OPA361 especially well suited for use in the TV-out function in portable designs. The lowest cost, highest performance and smallest total solution is achieved by using DC-coupled input and output, and fits into an area smaller than 5mm<sup>2</sup>. Internal gain resistors eliminate discrete components and the internal level shifter prevents clipping of the video sync signal by raising the signal into the amplifier output's linear operating range. A shutdown feature reduces power consumption to 2.5μA with TV output disabled.

OPA360 is a fully-integrated solution with on-chip Gain of 2, an integrated 2-pole filter, and an input level shift circuit. OPA360 is ideally suited for use with TI's TMS320DM270/275/320™ and other industry video processors. The new OPA361 is designed and tested to work flawlessly with TI's new OMAP2420 and DaVinci™ TMS320DM420™ processors and facilitates automatic TV detection for simplified end-user interface. For those interested in tuning their designs for specific characteristics with a standard video amp, OPA358 offers excellent, low-cost video performance in a small SC70 package.

## Video Amplifiers

Voltage Feedback	Current Feedback	Filtered Amplifiers	Special Functions
— OPAy354 (2.5V to 5.5V)	— OPAy694 (±5V)	— OPAy360 (2.7V to 3.3V)	— OPA615 (±5V)
— OPAy355 (2.5V to 5.5V)	— OPAy691 (5V, ±5V)	— OPAy361 (2.5V to 3.3V)	— BUF602 (±5V, +5V, +3.3V)
— OPAy356 (2.5V to 5.5V)	— OPAy684 (5V, ±5V)	— THS7303 (2.7V to 5.5V)	— OPA861 (±5V)
— OPAy357 (2.5V to 5.5V)	— OPAy683 (5V, ±5V)	— THS7313 (2.7V to 5.5V)	
— THS4281 (2.7, ±7.5V)	— OPA693 (5V, ±5V)	— THS7353 (2.7V to 5.5V)	
— OPAy358 (2.7V to 3.3V)	— OPAy692 (5V, ±5V)		
— OPA360 (2.7V to 3.3V)	— OPA695 (5V, ±5V)		
— OPA361 (2.7V to 3.3V)			
— OPAy830 (2.8V, ±5.0)			
— OPAy832 (2.8V, ±5)			
— OPAy690 (5V, ±5V)			
— OPA842 (5V, ±5V)			
— OPAy820 (5V, ±5V)			
— TIVy675 (±5V)			

*Preview devices appear in BLUE.*

## Video Amplifiers

### 3-Channel, Low-Power, Video Buffer with I<sup>2</sup>C Control

#### THS7353

Get samples, datasheets, EVMs and app reports at: [www.ti.com/sc/device/THS7353](http://www.ti.com/sc/device/THS7353)

#### Key Features

- Selectable 5th-order LPF at 9-/16-/35MHz and 150MHz bypass mode
- Single supply: 2.7V to 5V operation
- Low quiescent current: 16.2mA at 3.3V
- I<sup>2</sup>C allows individual channel configurations
- Selectable input modes including DC, DC + offset, AC-bias, or AC-sync tip clamp
- RRO allows DC or AC coupling
- 2:1 input MUX
- 0dB gain—ideal for buffering ADCs
- External gain-adjustment capable
- Packaging: TSSOP-20

#### Applications

- HDTV display input video buffering
- PVR/DVDR video buffering
- USB and portable video capture
- Projector video buffering

The THS7353 is a low-power, single-supply, 3-channel integrated video buffer incorporating a selectable 5th-order Butterworth anti-aliasing/DAC reconstruction filter to eliminate data converter images. Each channel of the THS7353 is individually I<sup>2</sup>C configurable for all functions, which makes it flexible for any video buffering application.

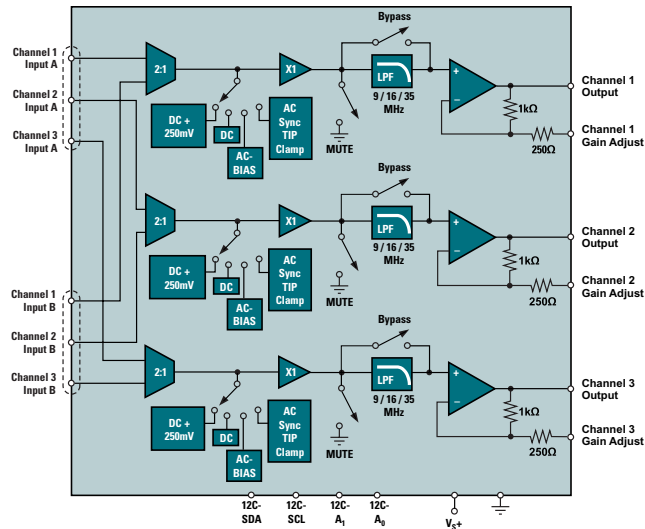

THS7353 functional block diagram.

### 3V Video Amplifier with Internal Gain and Filter, TV Detection

#### OPA361

Get samples, datasheets, EVMs and app reports at: [www.ti.com/sc/device/OPA361](http://www.ti.com/sc/device/OPA361)

#### Key Features

- Internal gain: 5.2V/V
- Compatible with 0.5Vpp video input
- Supports TV detection
- 2-pole reconstruction filter
- Input range includes ground
- Integrated level shifter
- Rail-to-rail output
- Shutdown current: 1.5μA
- Single supply: 2.5V to 3.3V
- Packaging: SC70-6, 2.0mm x 2.1mm

#### Applications

- Camera phones
- Digital still cameras
- Portable media players
- Set-top boxes
- Portable video

The OPA361 is optimized for battery-powered or low-voltage portable video applications. It is designed to be compatible with the video encoders embedded in TI's OMAP242x processors, DaVinci™ multimedia processors, or other application processors with 0.5Vpp video output. The TV-detection feature simplifies end-user interface by facilitating automatic start/stop of video transmission.

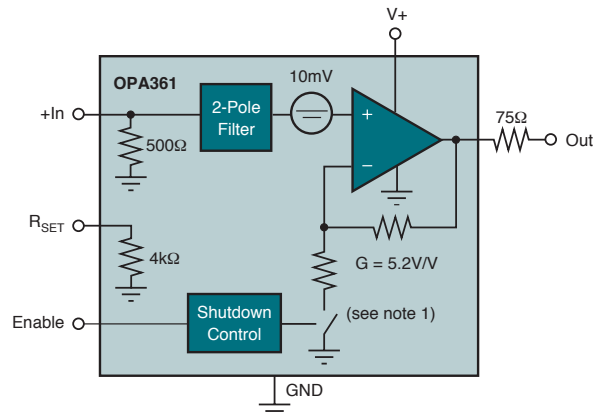

(1) Closed when enabled during normal operation; open when in shutdown.

OPA361 functional block diagram.



**Video Amplifiers (sorted by ascending G = +2 Bandwidth)**

Device	Description <sup>1</sup>	Ch.	SHDN	Supply Voltage (V)	-3dB at G = +2 Bandwidth (MHz)	0.1dB Gain Flatness (MHz)	Differential Gain (%)	Offset Phase (°)	Slew Rate (V/μs)	Offset Voltage (mV) (max)	I <sub>Q</sub> Per Ch. (mA) (typ)	Input Range (V)	RRO	Package(s)	Price*
<b>THS7313</b>	I <sup>2</sup> C, SD 5th-Order LPF, 6dB Gain, SAG	3	Y	2.7 to 5.5	8	4	0.07	0.12	35	35	6	0 to 2.4	Y	TSSOP-20	\$1.20
OPA358	Small Package, Low Cost	1	Y	2.7 to 3.3	40	12	0.3	0.7	55	6	5.2	GND -0.1 to (V+)-1	Y	SC-70	\$0.45
OPA360	G = 2, DC-Coupled, LPF, Use with DM270/275/320	1	Y	2.7 to 3.3	9MHz 2-Pole Filter	5	0.5	1	55	Level Shifter	6	GND to (V+)-1.5	Y	SC-70	\$0.49
<b>OPA361</b>	G = 5.22, DC-Coupled, LPF, TV detect, Use with OMAP2420/DM420	1	Y	2.5 to 3.3	9MHz 2-Pole Filter	5	0.5	1	55	Level Shifter	5.3	GND to 0.55	Y	SC-70	\$0.49
OPAy832	VFB <sup>1</sup> , Fixed Gain	1, 2	N	+2.8, ±5	80	—	0.1	0.16	350	7	4.25	-0.5 to 1.5	Y	SOT23, SOIC	\$0.70
OPAy354	VFB <sup>1</sup> , Low Cost	1, 2, 4	N	2.5 to 5.5	100	40	0.02	0.09	150	8	4.9	-0.1 to 5.4	Y	SOT23, SOIC, MSOP, TSSOP	\$0.67
OPAy357	VFB <sup>1</sup> , Low Cost, SHDN	1, 2	Y	2.5 to 5.5	100	40	0.02	0.09	150	8	4.9	-0.1 to 5.4	Y	SOT23, SOIC, MSOP	\$0.67
OPAy830	VFB <sup>1</sup>	1, 2, 4	N	+2.8, ±5.5	110	—	0.07	0.17	600	7	4.25	-0.45 to 1.2	Y	SO-8, SOT23	\$0.75
OPA842	VFB <sup>1</sup>	1	N	±5	150	56	0.003	0.008	400	1.2	20.2	±3.2	N	SOT23, SOIC	\$1.55
OPAy683	CFB <sup>1</sup>	1, 2	Y	±5, +5	150	37	0.06	0.03	540	1.5	0.9	±3.75	N	SOT23, SOIC	\$1.20
<b>THS7353</b>	I <sup>2</sup> C, Selectable SD/ED/HD/Bypass 5th-Order LPF, 0dB Gain	3	Y	2.7 to 5.5	9/16/35/150	5/9/20/25	0.15	0.3	40/70/150/300	20	5.9	0 to 3.4	Y	TSSOP-20	\$1.65
OPAy684	CFB <sup>1</sup>	1, 2, 3, 4	Y	±5, +5	160	19	0.04	0.02	820	3.5	1.7	±3.75	N	SOT23, SOIC	\$1.35
<b>THS7303</b>	I <sup>2</sup> C, Selectable SD/ED/HD/Bypass 5th-Order LPF, 6dB	3	Y	2.7 to 5.5	9/16/35/190	5/9.5/22/125	0.13	0.55	40/75/155/320	35	6	0 to 2.4	Y	TSSOP-20	\$1.65
OPAy355	VFB <sup>1</sup> , Low Cost, SHDN	1, 2, 3	Y	2.5 to 5.5	200	75	0.02	0.05	300	9	8.3	-0.1 to 3	Y	SOT23, SOIC, MSOP, TSSOP	\$0.69
OPAy356	VFB <sup>1</sup> , Low Cost	1, 2	N	2.5 to 5.5	200	75	0.02	0.05	300	9	8.3	-0.1 to 3	Y	SOT23, SOIC, MSOP	\$0.69
OPA656	VFB <sup>1</sup> , JFET-Input	1	N	±5	200	30	0.02	0.05	290	1.8	14	-4/+2.5	N	SOT23, SOIC	\$3.35
OPAy690	VFB <sup>1</sup>	1, 2, 3	Y	±5, +5	220	30	0.06	0.03	1800	4	5.5	±3.5	N	SOT23, SOIC	\$1.35
OPAy691	CFB <sup>1</sup>	1, 2, 3	Y	±5, +5	225	90	0.07	0.02	2100	2.5	5.1	±3.5	N	SOT23, SOIC	\$1.45
OPAy820	VFB <sup>1</sup>	1, 4	N	±.5, ±5	230	—	0.01	0.03	240	0.75	5.6	0.9 to 4.5	N	SOT23, SOIC	\$0.90
OPAy692	CFB <sup>1</sup> , Fixed Gain	1, 3	Y	±5, +5	240	120	0.07	0.02	2000	2.5	5.1	±3.5	N	SOT23, SOIC	\$1.15
<b>TIVy675</b>	Video Mux	1, 3	Y	+4, ±7	675, 600	200	0.04	0.013	2900, 2800	5	11	2.4	N	MSOP, SOIC, SSOP	\$1.20
OPAy694	CFB <sup>1</sup>	2	N	±5	690	—	0.03	0.015	1700	4.1	5	±2.5	N	SOT23, SOIC	\$1.25
OPA693	CFB <sup>1</sup> , Fixed Gain	1	Y	±5, +5	700	200	0.03	0.01	2500	2	13	±3.4	N	SOT23, SOIC	\$1.30
THS3201	CFB <sup>1</sup>	1	N	±5, +7.5	850	380	0.008	0.007	6200	3	14	±2.5	N	SOT23, SOIC, MSOP	\$1.60
THS3202	CFB <sup>1</sup>	2	N	±5, +7.5	975	380	0.008	0.03	4400	3	14	±2.6	N	SOIC, MSOP	\$2.90
OPA695	CFB <sup>1</sup>	1	Y	±5, +5	1400	320	0.04	0.007	4300	3	12.9	±3.3	N	SOT23, SOIC	\$1.35
<b>BUF602</b>	Closed-Loop Buffer >1GHz	1	N	±5, +3.3	N/A	240	0.15	0.04	8000	30	5.8	±4.0	N	SOT23, SOIC	\$0.85
<b>OPA615</b>	DC Restoration	1	N	±5	N/A	N/A	N/A	N/A	2500	N/A	13	±3.5	N	SO-14	\$4.25
<b>OPA861</b>	Transconductance	1	N	±5	N/A	N/A	—	—	900	12	5.4	±4.2	N	SOT23, SOIC	\$0.95

<sup>1</sup>VFB (Voltage Feedback), CFB (Current Feedback)

\* Suggested resale price in U.S. dollars in quantities of 1,000.

New products are listed in bold red.

Preview products are listed in bold blue.

## → Comparators

Comparator ICs are specialized op amps designed to compare two input voltages and provide a logic state output. They can be considered one-bit analog-to-digital converters.

The TI comparator portfolio consists of a variety of products with various performance characteristics, including: fast (ns) response time, wide input voltage ranges, extremely low quiescent current consumption and op amp and comparator combination ICs.

Comparator vs. Op Amp

	Comparator	Op Amp
Speed (Response time)	Yes	No
Logic Output	Yes	No
Wide Diff. Input Range	Yes	Yes
Low Offset Drift	No	Yes

In general, if a fast response time is required, use a comparator.

### Design Considerations

#### Output topology

- Open collector—connects to the logic supply through a pull-up resistor and allows comparators to interface to a variety of logic families.
- Push-pull—does not require a pull-up resistor. Because the output swings rail-to-rail, the logic level is dependent on the voltage supplies of the comparator.

**Response time (propagation delay)**—applications requiring “near real-time” signal response should consider comparators with nanosecond (ns) propagation delay. Note that as propagation delay decreases, supply current increases. Evaluate what mix of performance and power can be afforded. The TLV349x family offers a unique combination of speed/power with 5 $\mu$ s propagation delay on only 1 $\mu$ A of quiescent current.

**Combination comparator and op amp**—for input signals requiring DC level shifting and/or

gain prior to the comparator, consider the TLV230x (open drain) or TLV270x (push-pull) op amp and comparator combinations. These dual function devices save space and cost.

**Comparator and voltage reference**—comparators typically require a reference voltage to compare against. The TLV3011 is an integrated comparator and voltage reference combination in a space-saving SC70 package.

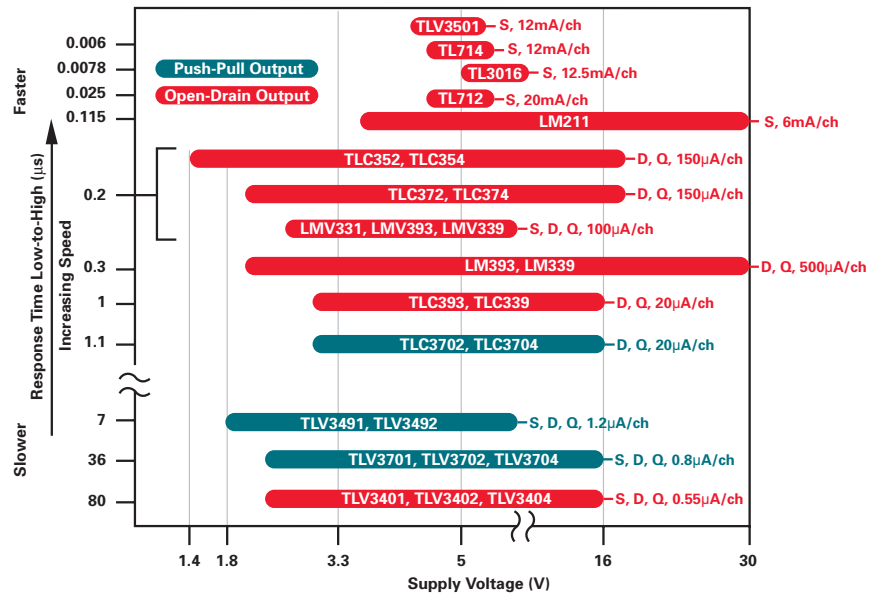

## High-Speed Comparator in SOT23

### TLV3501

Get samples and datasheets at: [www.ti.com/sc/device/TLV3501](http://www.ti.com/sc/device/TLV3501)

#### Key Features

- High speed: 4.5ns response at 20mV overdrive
- Beyond-the-rail common-mode input range
- Rail-to-rail, push-pull output
- Single-supply operation: 2.7V to 5.5V
- Packaging: SOT23

#### Applications

- Test and measurement
- Power supply monitoring
- Base stations

The TLV3501 is a high-speed comparator in a small SOT23 package. Designed for a variety of applications, TLV3501 offers very fast response relative to power consumption. It is specified over the extended temperature range of  $-40^{\circ}\text{C}$  to  $+125^{\circ}\text{C}$ .

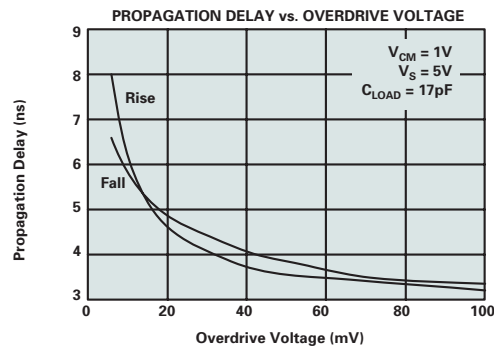

*TLV3501 performance characteristics.*



## Low-Power Comparators with Integrated Voltage Reference

### TLV3011, TLV3012

Get samples and datasheets at: [www.ti.com/sc/device/TLV3011](http://www.ti.com/sc/device/TLV3011) and [www.ti.com/sc/device/TLV3012](http://www.ti.com/sc/device/TLV3012)

#### Key Features

- Comparator with voltage reference:
  - TLV3011: open-drain output
  - TLV3012: push-pull output
- Integrated voltage reference: 1.2V
  - 1% initial accuracy, 40ppm/°C drift
- Low quiescent current: 5µA max
- Wide input common-mode range: 200mV beyond rails
- Propagation delay: 6µs
- Very low voltage operation: 1.8V to 5.5V
- Packaging: SC-70 and SOT23

#### Applications

- Battery voltage monitoring
- Power good function
- Low signal/voltage detection
- Relaxation oscillator

The TLV3011 is a low-power, open-drain output comparator; the TLV3012 is a push-pull output comparator. The integrated 1.242V series voltage reference offers low 100ppm/°C (max) drift, is stable with up to 10nF capacitive load and can provide up to 0.5mA (typ) of output current.

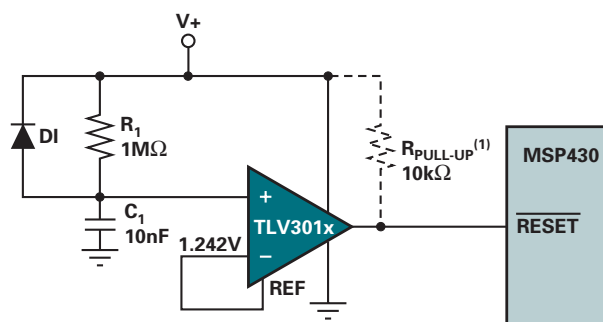

NOTE: (1) Use  $R_{PULL-UP}$  with the TLV3011 only.

*TLV3011 or TLV3012 configured to power-up reset for MSP430.*

## Comparators Selection Guide

Device	Description	Ch.	$I_Q$ Per Ch. (mA)	Output Current (mA)	$t_{RESP}$ Low-to-High (µs)	$V_S$ (min) (V)	$V_S$ (max) (V)	$V_{OS}$ (25°C) (mV)	Output Type	Package(s)	Price*
<b>High Speed, <math>t_{RESP} \leq 0.1\mu s</math></b>											
<b>TLV3501</b>	Ultra-High Speed, Low Power	1, 2	5	20	0.004	2.7	5.5	5	Push-Pull	SOT23	\$1.50
TL714	High Speed, 10mV (typ) Hysteresis	1	12	16	0.006	4.75	5.25	10	Push-Pull	PDIP, SOIC	\$2.16
TL3016	High Speed, Low Offset	1	12.5	—	0.0078	5	10	3	Open-Drain/Collector	SOIC, TSSOP	\$0.95
TL3116	Ultra Fast, Low Power, Precision	1	14.7	—	0.0099	5	10	3	Open-Drain/Collector	SOIC, TSSOP	\$0.95
TL712	Single, High Speed	1	20	16	0.025	4.75	5.25	5	Push-Pull	PDIP, SOIC, SOP	\$0.83
LM306	Single, Strobed, General Purpose	1	6.8	100	0.028	-6	12	5	Push-Pull	PDIP, SOIC	\$0.42
LM211	Single, High Speed, Strobed	1	6	—	0.115	3.5	30	3	Open-Drain/Collector	PDIP, SOIC	\$0.20
LM311	Single, High Speed, Strobed, Differential	1	7.5	—	0.115	3.5	30	7.5	Open-Drain/Collector	PDIP, SOIC, SOP, TSSOP	\$0.18
LM111	Single, Strobed, Differential	1	6	—	0.165	3.5	30	3	Open-Drain/Collector	CDIP, LCCC	\$1.37
<b>Low Power, <math>I_Q &lt; 0.5mA</math></b>											
TLV3401	Nanopower, Open-Drain, RRIO	1, 2, 4	0.00055	—	80	2.5	16	3.6	Open-Drain/Collector	MSOP, PDIP, SOIC, SOT23, TSSOP	\$0.60
TLV3701	Nanopower, Push-Pull, RRIO	1, 2, 4	0.0008	—	36	2.5	16	5	Push-Pull	MSOP, PDIP, SOIC, SOT23, TSSOP	\$0.60
TLV3491	Low Voltage, Excellent Speed/Power	1, 2	0.0012	—	< 0.1	1.8	5.5	15	Push-Pull	SOT23, SOIC, TSSOP	\$0.42
TLV2302	Sub-µPower, Op Amp and Comparator, RRIO	1, 2	0.0017	—	55	2.5	16	5	Open-Drain/Collector	MSOP, PDIP, SOIC, TSSOP	\$0.90
TLV2702	Sub-µPower, Op Amp and Comparator, RRIO	1, 2	0.0019	—	36	2.5	16	5	Push-Pull	MSOP, PDIP, SOIC, TSSOP	\$0.90
TLC3702	Dual and Quad, µPower	2, 4	0.02	4	1.1	3	16	5	Push-Pull	PDIP, SOIC, TSSOP	\$0.34
TLC393	Low Power, LM393 Replacement	2	0.02	6	1.1	3	16	5	Open-Drain/Collector	PDIP, SOIC, SOP, TSSOP	\$0.37

\*Suggested resale price in U.S. dollars in quantities of 1,000.

New products are listed in bold red.



## Comparators Selection Guide (Continued)

Device	Description	Ch.	I <sub>Q</sub> Per Ch. (mA) (max)	Output Current (mA) (min)	t <sub>RESP</sub> Low-to-High (μs)	V <sub>S</sub> (V) (min)	V <sub>S</sub> (V) (max)	V <sub>OS</sub> (25°C) (mV) (max)	Output Type	Package(s)	Price*
<b>Low Power, I<sub>Q</sub> &lt; 0.5mA (Continued)</b>											
TLC339	Quad, Low Power	4	0.02	6	1	3	16	5	Open-Drain/Collector	PDIP, SOIC, TSSOP	\$0.44
LP2901	Quad, Low Power, General Purpose	4	0.025	—	1.3	5	30	5	Open-Drain/Collector	PDIP, SOIC	\$0.56
LP339	Quad, Low Power, General Purpose	4	0.025	—	1.3	5	30	5	Open-Drain/Collector	PDIP, SOIC	\$0.49
LMV393	Dual, Low Voltage	2	0.1	10	0.2	2.7	5.5	7	Open-Drain/Collector	SOIC, TSSOP	\$0.34
LMV339	Quad, Low Voltage	4	0.1	—	0.2	2.7	5.5	7	Open-Drain/Collector	SOIC, TSSOP	\$0.36
LMV331	Single, Low Voltage	1	0.12	10	0.2	2.7	5.5	7	Open-Drain/Collector	SC70, SOT23	\$0.34
TLC372	Fast, Low Power	2, 4	0.15	6	0.2	2	18	5	Open-Drain/Collector	PDIP, SOIC, TSSOP	\$0.33
TLM3302	Quad, General Purpose	4	0.2	6	0.3	2	28	20	Open-Drain/Collector	PDIP, SOIC	\$0.46
LP211	Single, Strobed, Low Power	1	0.3	—	1.2	3.5	30	7.5	Open-Drain/Collector	SOIC	\$0.50
LP311	Single, Strobed, Low Power	1	0.3	1.6	1.2	3.5	30	7.5	Open-Drain/Collector	PDIP, SOIC, SOP	\$0.46
<b>Low Voltage, V<sub>S</sub> ≤ 2.7V (min)</b>											
TLC352	1.4V	2, 4	0.15	6	0.2	1.4	18	5	Open-Drain/Collector	PDIP, SOIC, TSSOP	\$0.40
TLV3491	Low Voltage, Excellent Speed/Power	1, 2, 4	0.0012	—	< 0.1	1.8	5.5	15	Push-Pull	SOT23, SOIC, TSSOP	\$0.42
TLV2352	Low Voltage	2, 4	0.125	6	0.2	2	8	5	Open-Drain/Collector	PDIP, SOIC, TSSOP	\$0.90
TLC372	Fast, Low Power	2	0.15	6	0.2	2	18	5	Open-Drain/Collector	PDIP, SOIC, TSSOP	\$0.33
LM3302	Quad, General Purpose	4	0.2	6	0.3	2	28	20	Open-Drain/Collector	PDIP, SOIC	\$0.46
LM2903	Dual, General Purpose	2	0.5	6	0.3	2	30	7	Open-Drain/Collector	PDIP, SOIC, SOP, TSSOP	\$0.22
LM293	Dual, General Purpose	2	0.5	6	0.3	2	30	5	Open-Drain/Collector	PDIP, SOIC	\$0.28
LM293A	Dual, General Purpose	2	0.5	6	0.3	2	30	3	Open-Drain/Collector	SOIC	\$0.36
LM393	Dual, General Purpose	2	0.5	6	0.3	2	30	5	Open-Drain/Collector	PDIP, SOIC, SOP, TSSOP	\$0.18
LM393A	Dual, General Purpose	2	0.5	6	0.3	2	30	3	Open-Drain/Collector	PDIP, SOIC, SOP, TSSOP	\$0.27
LM239	Quad, General Purpose	4	0.5	6	0.3	2	30	5	Open-Drain/Collector	PDIP, SOIC	\$0.28
LM239A	Quad, General Purpose	4	0.5	6	0.3	2	30	2	Open-Drain/Collector	SOIC	\$0.91
LM2901	Quad, General Purpose	4	0.625	6	0.3	2	30	3	Open-Drain/Collector	PDIP, SOIC, SOP, TSSOP	\$0.22
LM339	Quad, General Purpose	4	0.5	6	0.3	2	30	5	Open-Drain/Collector	PDIP, SOIC, SOP, SSOP, TSSOP	\$0.18
LM339A	Quad, General Purpose	4	0.5	6	0.3	2	30	3	Open-Drain/Collector	PDIP, SOIC, SOP	\$0.27
TL331	Single, Differential	1	0.7	6	0.3	2	36	5	Open-Drain/Collector	SOT23	\$0.28
LM139	Quad	4	0.5	6	0.3	2	36	5	Open-Drain/Collector	SOIC	\$0.54
LM139A	Quad	4	0.5	6	0.3	2	36	2	Open-Drain/Collector	SOIC	\$0.94
LM193	Dual	4	0.5	6	0.3	2	36	5	Open-Drain/Collector	SOIC	\$0.30
TLV3401	Nanopower, RRIO	1, 2, 4	0.00055	—	80	2.5	16	3.6	Open-Drain/Collector	MSOP, PDIP, SOIC, SOT23, TSSOP	\$0.60
TLV3701	Nanopower, RRIO	1, 2, 4	0.0008	—	36	2.5	16	5	Push-Pull	MSOP, PDIP, SOIC, SOT23, TSSOP	\$0.60
LMV331	Single, Low Voltage	1	0.12	10	0.2	2.7	5.5	7	Open-Drain/Collector	SC70, SOT23	\$0.34
LMV393	Dual, Low Voltage	2	0.1	10	0.2	2.7	5.5	7	Open-Drain/Collector	SOIC, TSSOP	\$0.34
LMV339	Quad Low-Voltage Comparators	4	0.1	—	0.2	2.7	5.5	7	Open-Drain/Collector	SOIC, TSSOP	\$0.36
<b>Combination Comparators and Op Amps</b>											
TLV2302	Sub-μPower, Op Amp and Comparator, RRIO	2	0.0017	—	55	2.5	16	5	Open-Drain/Collector	MSOP, PDIP, SOIC, TSSOP	\$0.90
TLV2702	Sub-μPower, Op Amp and Comparator, RRIO	2, 4	0.0019	—	36	2.5	16	5	Push-Pull	MSOP, PDIP, SOIC, TSSOP	\$0.90
<b>Comparator and Voltage Reference</b>											
TLV3011	μPower, Comparator with 1.242V Reference	1	0.003	5	6	1.8	5.5	15	Open-Drain/Collector	SC-70, SOT23	\$0.75
TLV3012	μPower, Comparator with 1.242V Reference	1	0.003	5	6	1.8	5.5	15	Push-Pull	SC-70, SOT23	\$0.75

\*Suggested resale price in U.S. dollars in quantities of 1,000.



The difference amplifier is a moderate input impedance, closed-loop, fixed-gain block that allows the acquisition of signals in the presence of ground loops and noise. These devices can be used in a variety of circuit applications—precision, general-purpose, audio, low-power, high-speed and high-common-mode voltage applications.

### Difference Amplifier

The basic difference amplifier employs an op amp and four on-chip, precision, laser trimmed resistors. The INA132, for example, operates on 2.7V to 36V supplies and consumes only 160 $\mu$ A. It has a differential gain of 1 and high common-mode rejection. The output signal can be offset by applying a voltage to the Ref pin. The output sense pin can be connected directly at the load to reduce gain error. Because the resistor network divides down the input voltages, difference amplifiers can operate with input signals that exceed the power supplies.

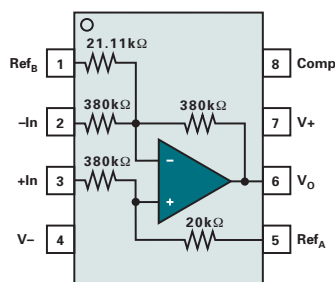

INA132 functional block diagram.

### High Common-Mode Voltage Difference Amplifier Topology

A five-resistor version of the simple difference amplifier results in a device that can operate with very high levels of common-mode voltage—far beyond its power supply rails. For example, the INA117 can sense differential signals in the presence of common-mode voltages as high as  $\pm 200$ V while being powered from  $\pm 15$ V. This device is very useful in measuring current from a high-voltage power supply through a high-side shunt resistor.

### Should I Use a Difference Amplifier or Instrumentation Amplifier?

**Difference amplifiers** excel when measuring signals with common-mode voltages greater than the power supply rails, when there is a low power requirement, when a small package is needed, when the source impedance is low or when a low-cost differential amp is required. The difference amp is a building block of the instrumentation amp.

**Instrumentation amplifiers** are designed to amplify low-level differential signals where the maximum common-mode voltage is within the supply rails. Generally, using an adjustable gain block, they are well-suited to single-supply applications. The three-op-amp topology works well down to Gain = 1, with a performance advantage in AC CMR. The two-op-amp topology is appropriate for tasks requiring a small package footprint and a gain of 5 or greater. It is the best choice for low-voltage, single-supply applications.

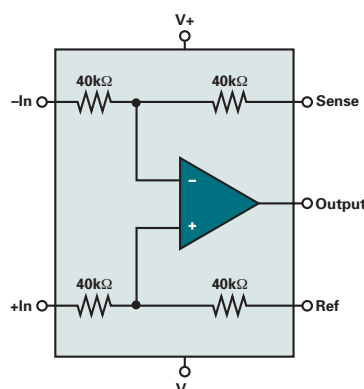

INA132 functional block diagram.

### Design Considerations

**Power supply**—common-mode voltage is always a function of the supply voltage. The INA103 instrumentation amplifier is designed to operate on voltage supplies up to  $\pm 25$ V, while the INA122 difference amp can be operated from a 2.2V supply.

**Output voltage swing**—lower supply voltage often drives the need to maximize dynamic range by swinging close to the rails.

**Common-mode input voltage range**—selection of the most suitable difference amp begins with an understanding of the input voltage range. Some offer resistor networks that divide down the input voltages, allowing operation with input signals that exceed the power supplies. A five-resistor version of the simple difference amplifier results in a device that can operate with very high levels of common-mode voltage—far beyond the supply rails.

**Gain**—signal amplification needed for desired circuit function must be considered. With the uncommitted on-chip op amp, the INA145 and the INA146 can be configured for gains of 0.1 to 1000.

**Sensor impedance**—should be  $< 0.001$  of difference amp input impedance to retain CMR and gain accuracy. In other words, the amp input impedance should be 1,000 times higher than the source impedance.

**Offset voltage drift ( $\mu$ V/ $^{\circ}$ C)**—input offset voltage changes over temperature. This is more critical in applications with changing ambient temperature.

**Quiescent current**—often of high importance in battery-powered applications, where amplifier power consumption can greatly influence battery life.

**Slew rate**—if the signal is reporting a temperature, force or pressure, slew rate is not generally of great concern. If the signal is for an electronic event, (e.g., current, power output) a fast transition may be needed.

**Common-mode rejection**—a measure of unwanted signal rejection and the amp's ability to extract a signal from surrounding DC, power line or other electrical noise.



## → Difference Amplifiers

### High-Speed, Precision, Level Translation Difference Amplifier

#### INA159

NEW

Get samples and datasheets at: [www.ti.com/sc/device/INA159](http://www.ti.com/sc/device/INA159)

#### Key Features

- Gain of 0.2 interface between  $\pm 10\text{V}$  signals and low-voltage, single-supply ADCs
- Wide bandwidth: 1.5MHz
- High slew rate:  $8\text{V}/\mu\text{s}$
- Low offset voltage:  $100\mu\text{V}$
- Low offset drift:  $\pm 2\mu\text{V}/^\circ\text{C}$
- Linearity: 0.01% FSR
- Single supply:  $+2.7\text{V}$  to  $+5.5\text{V}$

#### Applications

- Industrial process control
- Instrumentation
- Differential-to-single-ended conversion
- Audio line receiver

The INA159 is a level translation difference amplifier. It acts as a translator between  $\pm 10\text{V}$  levels and the input of single-supply ADCs typically operating at 5V. The INA159 accomplishes this with a gain of 0.2 along with a convenient voltage-divider reference input simplifying the biasing of the INA159's quiescent output to the optimum point for the ADC. The INA159 has a robust output stage, excellent frequency response and high slew rate.

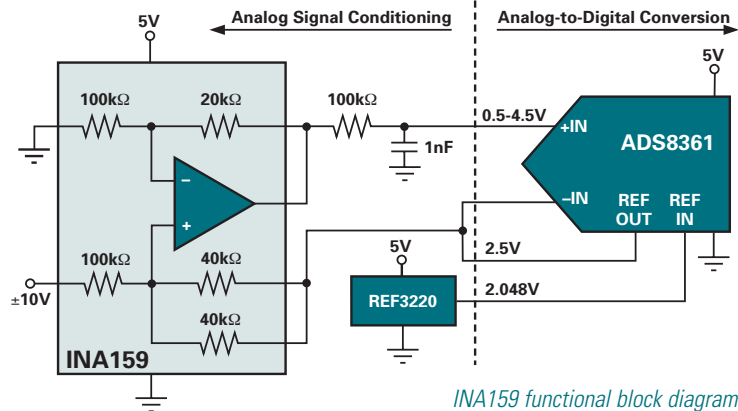

INA159 functional block diagram.

### Difference Amplifiers Selection Guide

Device	Description	Ch.	Gain	Offset ( $\mu\text{V}$ ) (max)	Offset Drift ( $\mu\text{V}/^\circ\text{C}$ ) (max)	CMRR (dB) (min)	BW (MHz) (typ)	Output Voltage Swing (V) (min)	Power Supply (V)	$I_0$ Per Ch. (mA) (max)	Package(s)	Price*
<b>General Purpose</b>												
INA105	Precision, Unity-Gain	1	1	250	10	86	1	(V+) -5 to (V-) +5	$\pm 5$ to $\pm 18$	2	SOIC8	\$2.80
INA106	Precision, Fixed G=10	1	10	200	0.2	86	5	(V+) -5 to (V-) +5	$\pm 5$ to $\pm 18$	2	SOIC-8	\$5.00
INA132	$\mu$ Power, Single Supply, High Precision	1	1	250	5	76	0.3	(V+) -1 to (V-) +0.5	$+2.7$ to $+36$	0.185	DIP, SO	\$1.05
INA2132	Dual INA132	2	1	250	5	76	0.3	(V+) -1 to (V-) +0.5	$+2.7$ to $+36$	0.185	DIP, SO	\$1.80
INA133	High Speed, Precision	1	1	450	5	80	1.5	(V+) -1.5 to (V-) +1	$\pm 2.25$ to $\pm 18$	1.2	SOIC-8	\$1.05
INA2133	Dual INA133	2	1	450	5	80	1.5	(V+) -1.5 to (V-) +1	$\pm 2.25$ to $\pm 18$	1.2	SOIC-14	\$1.80
INA143	High Speed, Precision, G = 10 or 1/10	1	10, 1/10	250	3	80	0.15	(V+) -1.5 to (V-) +1	$\pm 2.25$ to $\pm 18$	1.2	SOIC-8	\$1.05
INA2143	Dual INA143	2	10, 1/10	250	3	86	0.15	(V+) -1.5 to (V-) +1	$\pm 2.25$ to $\pm 18$	1.2	SOIC-14	\$1.70
INA145	Resistor Programmable Gain	1	1 to 500	1000	10	76	0.5	(V+) -1 to (V-) +0.5	$\pm 2.25$ to $\pm 18$	0.7	SOIC-8	\$1.50
INA152	$\mu$ Power, High Precision	1	1	1500	15	80	0.8	(V+) -0.35 to (V-) +0.3	$+2.7$ to $+20$	0.65	MSOP-8	\$1.20
INA154	High Speed, Precision	1	1	750	20	80	3.1	(V+) -2 to (V-) +2	$\pm 4$ to $\pm 18$	2.9	SOIC-8	\$1.05
INA157	High Speed, Precision, G = 2 or 1/2	1	2, 1/2	500	20	86	4	(V+) -2 to (V-) +2	$\pm 4$ to $\pm 18$	2.9	SOIC-8	\$1.05
<b>INA159</b>	High Speed, Precision, Level Shift, G = 0.2	1	—	500	1.5	86	4	(V+) -0.1 to (V-) +0.048	1.8 to 5.5	1.4	MSOP-8	\$1.60
<b>Audio</b>												
INA134	Low Distortion, Audio Line Receiver, 0dB	1	1	1000	2	74	3.1	(V+) -2 to (V-) +2	$\pm 4$ to $\pm 18$	2.9	SOIC-8	\$1.05
INA2134	Dual INA134	2	1	1000	2	74	3.1	(V+) -2 to (V-) +2	$\pm 4$ to $\pm 18$	2.9	SOIC-14	\$1.70
INA137	Low Distortion, Audio Line Receiver, 6dB	1	2, 1/2	1000	2	74	4	(V+) -2 to (V-) +2	$\pm 4$ to $\pm 18$	2.9	SOIC-8	\$1.05
INA2137	Dual INA137	2	2, 1/2	1000	2	74	4	(V+) -2 to (V-) +2	$\pm 4$ to $\pm 18$	2.9	SOIC-14	\$1.70
DRV134	Audio Balanced Line Driver	1	2	10000	10 typ	46	1.5	(V+) -3 to (V-) +2	$\pm 4.5$ to $\pm 18$	5.5	SOIC16	\$1.95
DRV135	Audio Balanced Line Driver	1	2	10000	10 typ	46	1.5	(V+) -3 to (V-) +2	$\pm 4.5$ to $\pm 18$	5.5	SOIC-8	\$1.95
<b>High Common-Mode Voltage</b>												
INA117	$\pm 200\text{V}$ CM Range	1	1	1000	20	86	0.2	(V+) -5 to (V-) +5	$\pm 5$ to $\pm 18$	2	SOIC-8	\$2.70
INA146	$\pm 100\text{V}$ CM Range, Prog. Gain	1	0.1 to 100	5000	100	70	0.5	(V+) -1 to (V-) +0.15	$\pm 2.25$ to $\pm 18$	0.75	SOIC-8	\$1.70
INA148	$\pm 200\text{V}$ CM Range, $1\text{M}\Omega$ Input	1	1	5000	10 typ	70	0.1	(V+) -1 to (V-) +0.25	$\pm 1.35$ to $\pm 18$	0.3	SOIC-8	\$2.10

\*Suggested resale price in U.S. dollars in quantities of 1,000.

New products are listed in bold red.

## Analog Current Shunt Monitors



Current shunt monitors are a unique class of high common-mode voltage difference amplifiers that have the ability to operate on single, low-voltage supplies.

Current shunt monitors have a common-mode voltage range that is independent of power supply (as opposed to classical difference amplifiers where the common-mode voltage range is proportional to power supply voltage). Unlike most high common-mode voltage difference amplifiers, current sense shunt monitors have gains for sensing low differential voltages (50-100mV).

Current sensing can be done on either low-side (ground) or high-side (power supply). Low-side sensing is simple and requires no special components, but it often cannot be used because it either disturbs ground or requires additional wiring. Current shunt monitors are intended to make it easy to implement high-side current sensing. Discrete solutions to high-side sensing are difficult and costly to implement.

### Common-Mode Voltage

The common-mode voltage range is typically the first parameter to be considered and this breaks down into two basic categories of current shunt monitors: families that handle only positive common-mode voltages above +2.7V (with a choice of upper limits up to 75V); and a family that handles -16V to +80V. The ability to sense common-mode voltages at ground and below is required when the power supply that the current is being sensed from could get shorted out, or if the shunt resistor is in an inductive load that could be exposed to inductive kickback. In addition, a common-mode range to -16V allows the current shunt monitor to be used to sense current in -12V to -15V power supplies. Lastly, it easily withstands battery reversals in 12V automotive applications.

### Current Output vs. Voltage Output

Another broad category is the type of output. The current output families enable the gain to be set by selecting the value of an external load resistor. The fastest current shunt monitor is the INA139 or INA169. The only bi-directional offering is the current output INA170, and current output devices have a minimum common-mode voltage of +2.7V, with a maximum up to +75V.

Voltage output current shunt monitors have the advantage of a buffered voltage output which eliminates the need for an additional op amp in many applications. These devices are available in fixed gains of 20, 50 and 100. The voltage output current shunt monitors (INA193-INA198) all have a common-mode range of -16 to +80V.

**See Page 79 for a complete selection of digital output current shunt monitors**

## -16V to +80V Current Sense Monitor INA19x

Get samples, datasheets, and app reports at: [www.ti.com/INA19x](http://www.ti.com/INA19x)

### Key Features

- Common mode range: -16V to +80V
- Specified supply range: 2.7V to 18V
- Three transfer functions: 20V/V, 50V/V, 100V/V
- Only 3% (max) error over -40°C to +125°C
- Bandwidth: 500kHz
- Quiescent current: 700µA
- Packaging: SOT23

### Applications

- Fault detection
- Power supplies
- Motor control
- Industrial automation
- White goods
- Test and measurement
- Automotive systems
- E-meter: reverse current sense

The INA19x voltage output high-side current shunt monitor features -16V to +80V of common-mode voltage range making it capable of withstanding shorts and voltage reversals typical of demanding automotive applications. Available in three gain ranges of 20V/V, 50V/V and 100V/V, the INA19x offers flexible performance in a SOT23 package.

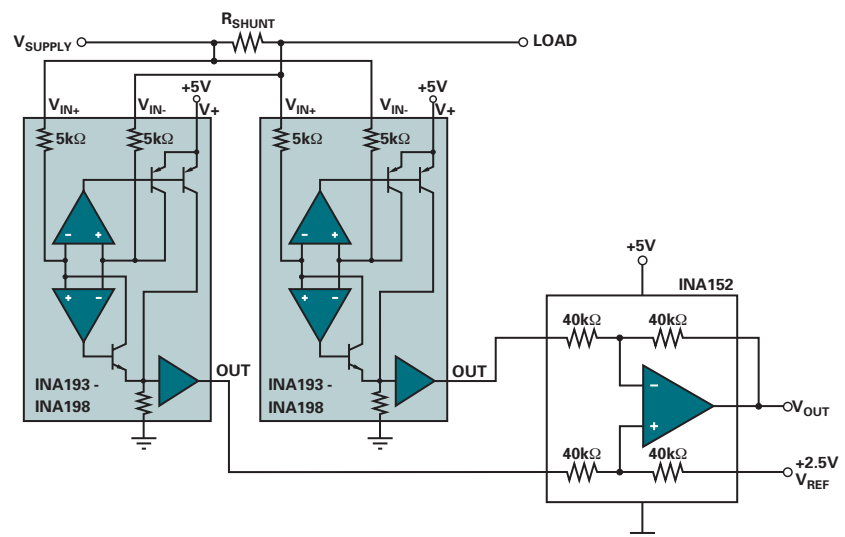

INA19x used for bi-directional current shunt monitoring.

## ➔ Analog Current Shunt Monitors

### –16V to +80V, High-Side Current Shunt Monitors with Integrated Dual Comparators INA206, INA207, INA208

**PREVIEW\***

Get samples, datasheets, and app reports at: [www.ti.com/sc/device/INA206](http://www.ti.com/sc/device/INA206), [www.ti.com/sc/device/INA207](http://www.ti.com/sc/device/INA207) and [www.ti.com/sc/device/INA208](http://www.ti.com/sc/device/INA208)

#### Key Features

- Extended common mode input range: –16V to +80V
- Integrated dual open drain comparators
- 1.2V reference
- Low offset: 2mV
- Rail-to-rail output voltage
- Single supply: 2.7V to 18V
- Packaging: MSOP, SO-14, TSSOP

#### Applications

- Notebook computers
- Cell phones
- Telecom equipment
- Power management
- Battery chargers

The INA206/207/208 feature dual comparators and 1.2V reference. These devices are ideal for multilevel watchdog systems, window comparators, or power good detection. Convenient default trip points are provided at each comparator of 0.6V, which can be overridden by external inputs if desired. One of the comparators has a latching capability, while the other comparator has a provision for a programmable delay by using a single external capacitor.

The current shunt amplifiers of the INA206/207/208 feature a common-mode range of –16V to +80V independent of supply voltage, and are powered by single-supply voltages from +2.7V to +18V. The INA20x provides a fully buffered voltage output available in three gains: INA206 = 20; INA207 = 50; INA208 = 100.

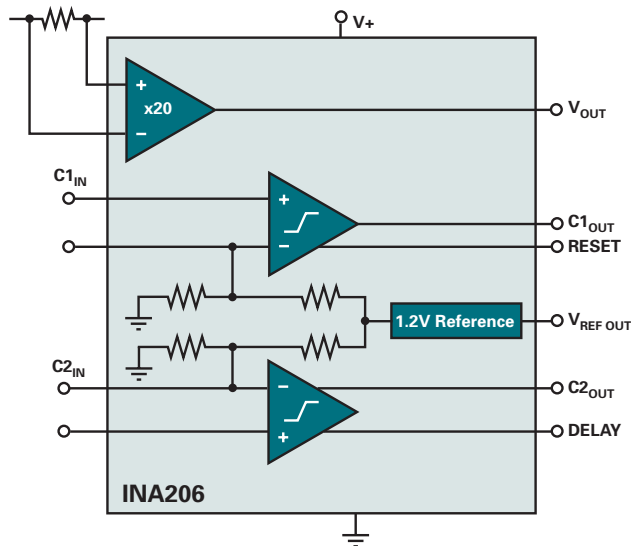

INA206/207/208 functional block diagram. \*Expected Release Date 3Q 2006

### Current Shunt Monitors Selection Guide

Device	Description	Ch.	Gain	Offset ( $\mu$ V) (max)	Offset Drift ( $\mu$ V/ $^{\circ}$ C) (max)	CMRR (dB) (typ)	BW (MHz) (typ)	Output Voltage Swing (V) (min)	Power Supply (V)	$I_0$ Per Ch. (mA) (max)	Package	Price*
<b>Voltage-Output, High-Side Current Shunt Monitors</b>												
INA19x	–16 to +80V CMV	1	20, 50, 100V/V	2000	1	100	0.5	V(+)-0.1 to V(-)+0.05	+2.7 to 18	0.9	SOT23-5	\$0.80
INA20x	Dual Comparator, $V_{REF}$	1	20, 50, 100V/V	2000	1	100	0.5	V(+)-0.1 to V(-)+0.05	+2.7 to 18	0.9	SOT23-5	\$0.80
<b>Current-Output, High-Side Current Shunt Monitor</b>												
INA138	36V (max)	1	200mA/V	1000	1	120	0.8	0 to V(+)-0.8	+2.7 to 36	0.045	SOT23-5	\$0.95
INA168	60V (max)	1	200mA/V	1000	1	120	0.8	0 to V(+)-0.8	+2.7 to 60	0.045	SOT23-5	\$1.25
INA139	High Speed, 40V (max)	1	1000mA/V	1000	1	100	0.44	0 to V(+)-1.2	+2.7 to 40	0.125	SOT23-5	\$0.99
INA169	High Speed, 60V (max)	1	1000mA/V	1000	1	100	0.44	0 to V(+)-1.2	+2.7 to 60	0.125	SOT23-5	\$1.25
<b>Bidirectional Current Shunt Monitor</b>												
INA170	60V (max)	1	1 to 100mA/V	1000	1	100	0.4	0 to V(+)-1.2	+2.7 to 40	0.125	VSSOP-8	\$1.25

\*Suggested resale price in U.S. dollars in quantities of 1,000.

New products are listed in **bold red**.  
Preview products are listed in **bold blue**.

## Instrumentation Amplifiers



The instrumentation amplifier (IA) is a high input impedance, closed-loop, fixed- or adjustable-gain block that allows for the amplification of low-level signals in the presence of common-mode errors and noise. TI offers many types of instrumentation amplifiers including single-supply, low-power, high-speed and low-noise devices. These instrumentation amplifiers are available in either the traditional three-op-amp or in the cost-effective two-op-amp topology.

### Three-Op-Amp Version

The three-op-amp topology is the benchmark for instrumentation amplifier performance. These devices provide a wide gain range (down to  $G = 1$ ) and generally offer the highest performance. Symmetrical inverting and non-inverting gain paths provide better common-mode rejection at high frequencies. Some types use current-feedback-type input op amps which maintain excellent bandwidth in high gain.

### Two-Op-Amp Version

The two-op-amp topology can provide wider common-mode voltage range, especially in low-voltage, single-supply applications. Their simpler internal circuitry allows lower cost, lower quiescent current and smaller package sizes. This topology, however, does not lend itself to gains less than four (INA125) or five (all others).

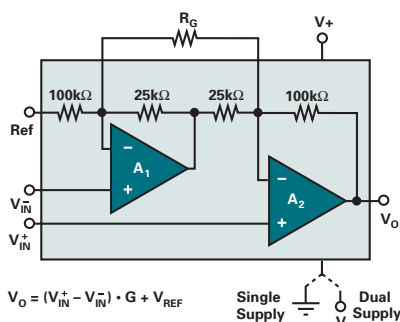

$V_O = (V_{IN-} - V_{IN+}) \cdot G + V_{REF}$

Two-op-amp topology provides wider common-mode range in low-voltage, single-supply applications.

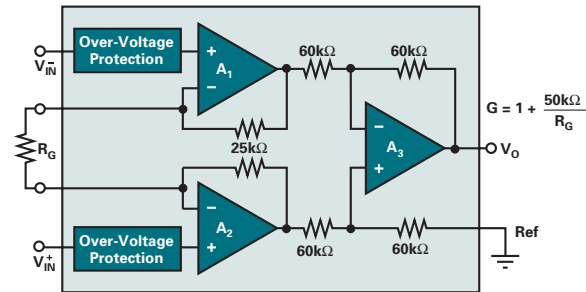

The three-op-amp topology is the benchmark for instrumentation amplifier performance.

### Design Considerations

**Supply voltage**—TI has developed a series of low-voltage, single-supply, rail-to-rail instrumentation amps suitable for a wide variety of applications requiring maximum dynamic signal range.

**Gain requirement**—for high-gain applications consider a low total noise device, because drift, input bias current and voltage offset all contribute to error.

**Common-mode voltage range**—the voltage input range over which the amplifier can operate and the differential pair behaves as a linear amplifier for differential signals.

**Input bias current**—can be an important factor in many applications, especially those sensing a low current or where the sensor impedance is very high. The INA116 requires only 3fA typical of input bias current.

**Offset voltage and drift**—IAs are generally used in high-gain applications, where any amp errors are amplified by the circuit gain. This can become a significant portion of the overall signal unless  $V_{OS}$  and drift are taken into account. Bipolar amps excel in limiting voltage errors related to offset and drift in low source impedance applications.

**Current-feedback vs. voltage-feedback input stage**—appropriate for designers needing higher bandwidth or a more consistent 3dB rolloff frequency over various gain settings. The INA128 and INA129 provide a significantly higher 3dB rolloff frequency than

voltage-feedback input stage instrumentation amps and have a 3dB rolloff at essentially the same frequency in both  $G = 1$  and  $G = 10$  configurations.

### Technical Information

IAs output the difference accurately between the input signals providing Common-Mode Rejection (CMR). It is the key parameter and main purpose for using this type of device. CMR measures the device's ability to reject signals that are common to both inputs.

IAs are often used to amplify the differential output of a bridge sensor, amplifying the tiny bridge output signals while rejecting the large common-mode voltage. They provide excellent accuracy and performance, yet require minimal quiescent current. Gain is usually set with a single external resistor.

In some applications unwanted common-mode signals may be less conspicuous. Real-world ground interconnections are not perfect. What may, at first, seem to be a viable single-ended amplifier application can become an accumulation of errors. Error voltages caused by currents flowing in ground loops sum with the desired input signal and are amplified by a single-ended input amp. Even very low impedance grounds can have induced voltages from stray magnetic fields. As accuracy requirements increase, it becomes more difficult to design accurate circuits with a single-ended input amplifier. The differential input instrumentation amplifier is the answer.

## Instrumentation Amplifiers

### Single-Supply, RRIO, Low-Offset, Low-Drift Instrumentation Amplifiers INA326, INA327 (Shutdown Version)

Get samples, datasheets and app reports at: [www.ti.com/sc/device/INA326](http://www.ti.com/sc/device/INA326) and [www.ti.com/sc/device/INA327](http://www.ti.com/sc/device/INA327)

#### Key Features

- Low offset: 100 $\mu$ V (max)
- Low offset drift: 0.4 $\mu$ V/ $^{\circ}$ C (max)
- Excellent long-term stability
- Very-low 1/f noise
- True rail-to-rail I/O
- Input common-mode range:
  - 20mV below negative rail
  - 100mV above positive rail
- Wide output swing: within 10mV of rails
- Single supply range: +2.7V to +5.5V
- Temp range:  $-40^{\circ}$ C to  $+125^{\circ}$ C (INA327)
- Packaging: MSOP-8, MSOP-10

#### Applications

- Low-level transducer amplifier for bridges, load cells, thermocouples
- Wide dynamic range sensor measurements
- High-resolution test systems
- Weigh scales
- Multi-channel data acquisition systems
- Medical instrumentation

The INA326 uses a new, unique internal circuit topology that provides true rail-to-rail input. Unlike other instrumentation amplifiers, it can linearly process inputs to 20mV below the negative power supply rail, and 100mV above the positive power supply rail. Conventional instrumentation amplifier input topologies cannot deliver such wide dynamic performance.

In most instrumentation amplifiers, the ability to reject common-mode signals is derived through a combination of input amplifier CMR and accurately matched resistor ratios. The INA326 converts the input voltage to a current, allowing the input amplifiers to accurately match and reject common-mode input voltage and power supply variation without the use of resistors.

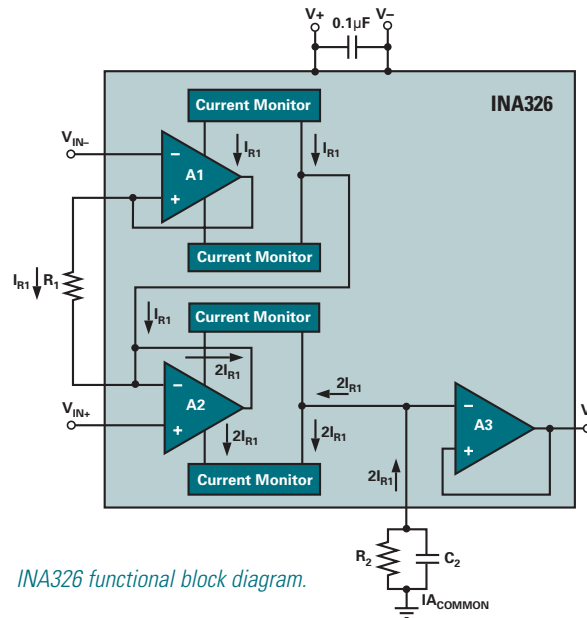

INA326 functional block diagram.

### 2MHz Bandwidth, Rail-to-Rail Output, Single-Supply Instrumentation Amplifiers INA332, INA2332

Get samples, datasheets, and app reports at: [www.ti.com/sc/device/INA332](http://www.ti.com/sc/device/INA332) and [www.ti.com/sc/device/INA2332](http://www.ti.com/sc/device/INA2332)

#### Key Features

- High gain accuracy:  $G = 5$ , 0.07%, 2ppm/ $^{\circ}$ C
- High CMRR: 73dB DC, 50dB at 45kHz
- Low bias current: 0.05pA
- Bandwidth: 2MHz
- Slew rate: 5V/ $\mu$ s
- Rail-to-rail output swing:  $(V_+) - 0.02V$
- Low quiescent current: 490 $\mu$ A max/ch
- Packaging: MSOP-8 single, SSOP-14 dual

#### Applications

- Industrial sensors:
  - Bridge, RTD, thermocouple, position
- Physiological amplifiers: ECG, EEG, EMG
- Field utility meters
- PCMCIA cards
- Test equipment
- Automotive instrumentation

The INA332 and INA2332 are rail-to-rail output, low-power, gain = 5, CMOS instrumentation amplifiers that operate on 2.7V to 5.5V supplies. They offer excellent speed/power ratio with 2MHz bandwidth and 490 $\mu$ A/channel supply current. Available shutdown/enable function adds additional power savings by reducing current to 0.01 $\mu$ A.

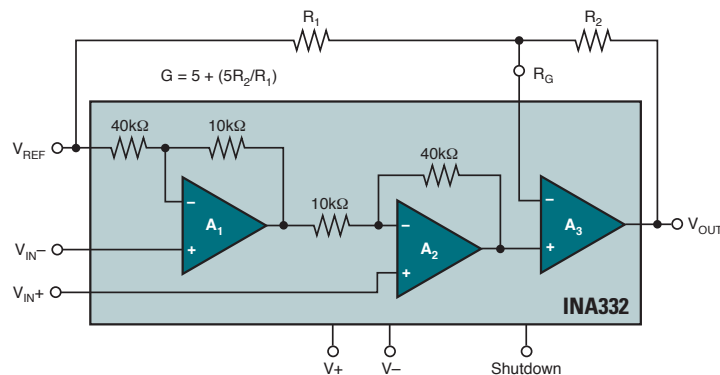

INA332 functional block diagram.



## Single-Supply Instrumentation Amplifiers



## Single-Supply Instrumentation Amplifiers Selection Guide

Device	Description	Gain	Non Linearity (%) (max)	Input Bias Current (nA) (max)	Offset at G = 100 ( $\mu$ V) (max)	Offset Drift ( $\mu$ V/ $^{\circ}$ C) (max)	CMRR at G = 100 (dB) (min)	BW at G = 100 (kHz) (min)	Noise 1kHz (nV/ $\sqrt$ Hz) (typ)	Power Supply (V)	$I_q$ Per Amp (mA) (max)	Package(s)	Price*
<b>Single-Supply, Low Power, <math>I_q &lt; 525\mu</math>A per Instrumentation Amp</b>													
INA321	RRO, SHDN, Low Offset, Gain Error, Wide Temp	5 to 1000	0.01	0.01	1000	7 <sup>1</sup>	90	50	100	2.7 to 5.5	0.06	MSOP-8	\$1.10
INA2321	Dual INA321	5 to 1000	0.01	0.01	1000	7 <sup>1</sup>	90	50	100	2.7 to 5.5	0.06	TSSOP-14	\$1.75
INA322	RRO, SHDN, Wide Temp, Low Cost	5 to 1000	0.01	0.01	10000	7	60	50	100	2.7 to 5.5	0.06	MSOP-8	\$0.95
INA2322	Dual INA322	5 to 1000	0.01	0.01	10000	7	60	50	100	2.7 to 5.5	0.06	TSSOP-14	\$1.50
INA122	$\mu$ Power, RRO, CM to GND	5 to 10000	0.012	25	250	3	90	5	60	2.2 to 36	0.085	DIP-8, SOIC-8	\$2.10
INA332	RRO, Wide BW, SHDN, Wide Temp, Low Cost	5 to 1000	0.01	0.01	10000	7 <sup>1</sup>	60	500	100	2.7 to 5.5	0.1	MSOP-8	\$0.85
INA2332	Dual INA332	5 to 1000	0.01	0.01	10000	7 <sup>1</sup>	60	500	100	2.7 to 5.5	0.1	MSOP-8	\$1.35
INA126	$\mu$ Power, $< 1V V_{SAT}$ , Low Cost	5 to 10000	0.012	25	250	3	83	9	35	2.7 to 36	0.2	DIP/SO/MSOP-8	\$1.05
INA2126	Dual INA126	5 to 10000	0.012	25	250	3	83	9	35	2.7 to 36	0.2	DIP/SO/MSOP-16	\$1.70
INA118	Precision, Low Drift, Low Power <sup>2</sup>	1 to 10000	0.002	5	55	0.7	107	70	10	2.7 to 36	0.385	DIP-8, SOIC-8	\$4.15
INA331	RRO, Wide BW, SHDN, Wide Temp	5 to 1000	0.01	0.01	500	5 <sup>1</sup>	90	2000	46	2.7 to 5.5	0.5	MSOP-8	\$1.10
INA2331	Dual INA331	5 to 1000	0.01	0.01	1000	5 <sup>1</sup>	80	2000	46	2.7 to 5.5	0.5	TSSOP-14	\$1.80
INA125	Internal Ref, Sleep Mode <sup>2</sup>	4 to 10000	0.01	25	250	2	100	4.5	38	2.7 to 36	0.525	DIP-8, SOIC-16	\$2.05
<b>Single-Supply, Low Input Bias Current, <math>I_B &lt; 50\mu</math>A</b>													
INA155	Low Offset, RRO, Wide Temp, SR = 6.5V/ $\mu$ s	10, 50	0.015	0.01	1000	5 <sup>1</sup>	86	110	40	2.7 to 5.5	2.1	MSOP-8	\$1.10
INA156	Low Offset, RRO, Low Cost, Wide Temp, SR = 6.5V/ $\mu$ s	10, 50	0.015	0.01	8000	5 <sup>1</sup>	86	110	40	2.7 to 5.5	2.1	SOIC-8, MSOP-8	\$0.95
INA321	RRO, SHDN, Low Offset, Gain Error, Wide Temp	5 to 1000	0.01	0.01	1000	7 <sup>1</sup>	90	50	100	2.7 to 5.5	0.06	MSOP-8	\$1.10
INA2321	Dual INA321	5 to 1000	0.01	0.01	1000	7 <sup>1</sup>	90	50	100	2.7 to 5.5	0.06	TSSOP-14	\$1.75
INA322	RRO, SHDN, Wide Temp, Low Cost	5 to 1000	0.01	0.01	10000	7	60	50	100	2.7 to 5.5	0.06	MSOP-8	\$0.95
INA2322	Dual INA322	5 to 1000	0.01	0.01	10000	7	60	50	100	2.7 to 5.5	0.06	TSSOP-14	\$1.50
INA331	RRO, Wide BW, SHDN, Wide Temp	5 to 1000	0.01	0.01	500	5 <sup>1</sup>	90	2000	46	2.7 to 5.5	0.5	MSOP-8	\$1.10
INA2331	Dual INA331	5 to 1000	0.01	0.01	1000	5 <sup>1</sup>	80	2000	46	2.7 to 5.5	0.5	TSSOP-14	\$1.80
INA332	RRO, Wide BW, SHDN, Wide Temp, Low Cost	5 to 1000	0.01	0.01	10000	7 <sup>1</sup>	60	500	100	2.7 to 5.5	0.1	MSOP-8	\$0.85
INA2332	Dual INA332	5 to 1000	0.01	0.01	10000	7 <sup>1</sup>	60	500	100	2.7 to 5.5	0.1	TSSOP-14	\$1.35
<b>Single-Supply, Precision, <math>V_{OS} &lt; 300\mu</math>V, Low <math>V_{OS}</math> Drift</b>													
INA118	Precision, Low Drift, Low Power <sup>2</sup>	1 to 10000	0.002	5	55	0.7	107	70	10	2.7 to 36	0.385	DIP-8, SOIC-8	\$4.15
<b>INA326</b>	RRIO, Auto-Zero, CM $>$ Supply, Low Drift	0.1 to 10000	0.01	2	100	0.4	100	1	33	2.7 to 5.5	3.4	MSOP-8	\$1.80
INA327	RRIO, Auto-Zero, SHDN, CM $>$ Supply, Low Drift	0.1 to 10000	0.01	2	100	0.4	100	1	33	2.7 to 5.5	3.4	MSOP-10	\$1.95
INA337	RRIO, Auto-Zero, Low Drift, CM $>$ Supply, Wide Temp	0.1 to 10000	0.01	2	100	0.4	106	1	33	2.7 to 5.5	3.4	MSOP-8	\$1.80
INA338	RRIO, Auto-Zero, Low Drift, CM $>$ Supply, SHDN, Wide Temp	0.1 to 10000	0.01	2	100	0.4	106	1	33	2.7 to 5.5	3.4	MSOP-10	\$1.95
INA122	$\mu$ Power, RRO, CM to GND	5 to 10000	0.012	25	250	3	90	5	60	2.2 to 36	0.085	DIP-8, SOIC-8	\$2.10
INA125	Internal Ref, Sleep Mode <sup>2</sup>	4 to 10000	0.01	25	250	2	100	4.5	38	2.7 to 36	0.525	DIP-8, SOIC-16	\$2.05
INA126	$\mu$ Power, $< 1V V_{SAT}$ , Low Cost	5 to 10000	0.012	25	250	3	83	9	35	2.7 to 36	0.2	DIP/SO/MSOP-8	\$1.05
INA2126	Dual INA126	5 to 10000	0.012	25	250	3	83	9	35	2.7 to 36	0.2	DIP/SO/MSOP-16	\$1.70
<b>Signal Amplifiers for Temperature Control</b>													
INA330	Optimized for Precision 10k $\Omega$ Thermistor Applications	—	—	0.23	—	0.009 $^{\circ}$ C <sup>1</sup>	—	1	0.0001 $^{\circ}$ C pp <sup>1</sup>	2.7 to 5.5	3.6	MSOP-10	\$1.55

<sup>1</sup> Typical<sup>2</sup> Internal +40V input protection<sup>3</sup> -40 $^{\circ}$ C to +85 $^{\circ}$ C

\*Suggested resale price in U.S. dollars in quantities of 1,000.

New products are listed in bold red.

## → Dual-Supply Instrumentation Amplifiers

### Dual-Supply Instrumentation Amplifiers Selection Guide

Device	Description	Gain	Non Linearity (%) (max)	Input Bias Current (nA) (max)	Offset at G = 100 (μV) (max)	Offset Drift (μV/°C) (max)	CMRR at G = 100 (dB) (min)	BW at G = 100 (kHz) (min)	Noise 1kHz (nV/√Hz) (typ)	Power Supply (V)	I <sub>Q</sub> Per Amp (mA) (max)	Package(s)	Price*
<b>Dual-Supply, Low-Power, I<sub>Q</sub> &lt; 850μA per Instrumentation Amp</b>													
INA122	μPower, RRO, CM to GND	5 to 10000	0.012	25	250	3	90	5	60	±1.3 to ±18	0.085	DIP-8, SOIC-8	\$2.10
INA126 <sup>2</sup>	μPower, < 1V VSAT, Low Cost	5 to 10000	0.012	25	250	3	83	9	35	±1.35 to ±18	0.2	DIP/SO/MSOP-8	\$1.05
INA118	Precision, Low Drift, Low Power <sup>1</sup>	1 to 10000	0.002	5	55	0.7	107	70	10	±1.35 to ±18	0.385	DIP-8, SOIC-8	\$4.15
INA121	Low Bias, Precision, Low Power <sup>1</sup>	1 to 10000	0.005	0.05	500	5	100	50	20	±2.25 to ±18	0.525	DIP-8, SO-8	\$2.50
INA125	Internal Ref, Sleep Mode <sup>1</sup>	4 to 10000	0.01	25	250	2	100	4.5	38	±1.35 to ±18	0.525	DIP-8, SOIC-16	\$2.05
INA128 <sup>2</sup>	Precision, Low Noise, Low Drift <sup>1</sup>	1 to 10000	0.002	5	60	0.7	120	200	8	±2.25 to ±18	0.8	DIP-8, SOIC-8	\$3.05
INA129	Precision, Low Noise, Low Drift, AD620 Second Source <sup>1</sup>	1 to 10000	0.002	5	60	0.7	120	200	8	±2.25 to ±18	0.8	DIP-8, SOIC-8	\$3.05
INA141 <sup>2</sup>	Precision, Low Noise, Low Power, Pin Compatible with AD6212 <sup>1</sup>	10, 100	0.002	5	50	0.5	110	200	8	±2.25 to ±18	0.8	DIP-8, SOIC-8	\$3.55
<b>Dual-Supply, Low Input Bias Current, I<sub>B</sub> &lt; 50pA</b>													
INA110	Fast Settle, Low Noise, Wide BW	1, 10, 100, 200, 500	0.01	0.05	280	2.5	106	470	10	±6 to ±18	4.5	DIP-16, SOIC-16	\$7.00
INA121	Precision, Low Power <sup>1</sup>	1 to 10000	0.005	0.05	500	5	100	50	20	±2.25 to ±18	0.525	DIP-8, SO-8	\$2.50
INA111	Fast Settle, Low Noise, Wide BW	1 to 1000	0.005	0.02	520	6	106	450	10	±6 to ±18	4.5	DIP-8, SO-16	\$4.20
INA116	Ultra Low I <sub>B</sub> 3fA (typ), with Buffered Guard Drive Pins <sup>1</sup>	1 to 1000	0.01	0.0001	5000	40	80	70	28	±4.5 to ±18	1.4	DIP-16, SO-16	\$4.20
<b>Dual-Supply, Precision V<sub>OS</sub> &lt; 300μV, Low V<sub>OS</sub> Drift</b>													
INA114	Precision, Low Drift <sup>1</sup>	1 to 10000	0.002	2	50	0.25	110	10	11	±2.25 to ±18	3	DIP-8, SO-16	\$4.20
INA115	Precision, Low Drift, w/Gain Sense Pins <sup>1</sup>	1 to 10000	0.002	2	50	0.25	120	10	11	±2.25 to ±18	3	SO-16	\$4.20
INA131	Low Noise, Low Drift <sup>1</sup>	100	0.002	2	50	0.25	110	70	12	±2.25 to ±18	3	DIP-8	\$3.80
INA141 <sup>2</sup>	Precision, Low Noise, Low Power, Pin Compatible with AD6212 <sup>1</sup>	10, 100	0.002	5	50	0.5	110	200	8	±2.25 to ±18	0.8	DIP-8, SOIC-8	\$3.55
INA118	Precision, Low Drift, Low Power <sup>1</sup>	1 to 10000	0.002	5	55	0.7	107	70	10	±1.35 to ±18	0.385	DIP-8, SOIC-8	\$4.15
INA128 <sup>2</sup>	Precision, Low Noise, Low Drift <sup>1</sup>	1 to 10000	0.002	5	60	0.7	120	200	8	±2.25 to ±18	0.8	DIP-8, SOIC-8	\$3.05
INA129	Precision, Low Noise, Low Drift, AD620 Second Source <sup>1</sup>	1 to 10000	0.002	5	60	0.7	120	200	8	±2.25 to ±18	0.8	DIP-8, SOIC-8	\$3.05
INA122	μPower, RRO, CM to GND	5 to 10000	0.012	25	250	3	90	5	60	±1.3 to ±18	0.085	DIP-8, SOIC-8	\$2.10
INA125	Internal Ref, Sleep Mode <sup>1</sup>	4 to 10000	0.01	25	250	2	100	4.5	38	±1.35 to ±18	0.525	DIP-8, SOIC-16	\$2.05
INA126 <sup>2</sup>	μPower, < 1V VSAT, Low Cost	5 to 10000	0.012	25	250	3	83	9	35	±1.35 to ±18	0.2	DIP/SO/MSOP-8	\$1.05
INA101	Low Noise, Wide BW, Gain Sense Pins, Wide Temp	1 to 1000	0.002	30	250	0.25	100	25	13	±5 to ±20	8.5	PDIP-14, SO-16	\$7.95
INA110	Fast Settle, Low Noise, Low Bias, Wide BW	1, 10, 100, 200, 500	0.01	0.05	280	2.5	106	470	10	±6 to ±18	4.5	CDIP-16	\$7.00
<b>Dual-Supply, Lowest Noise</b>													
INA103	Precision, Fast Settle, Low Drift, Audio, Mic Pre Amp, THD+N = 0.0009%	1, 100	0.00063	12000	255	1.2 <sup>3</sup>	100	800	1	±9 to ±25	13	DIP-16, SO-16	\$5.00
INA163	Precision, Fast Settle, Low Drift, Audio, Mic Pre Amp, THD+N = 0.002%	1 to 10000	0.00063	12000	300	1.2 <sup>3</sup>	100	800	1	±4.5 to ±18	12	SOIC-14	\$2.50
INA166	Precision, Fast Settle, Low Drift, Audio, Mic Pre Amp, THD+N = 0.09%	2000	0.005	12000	300	2.5 <sup>3</sup>	100	450	1.3	±4.5 to ±18	12	SO-14 Narrow	\$5.95
INA217	Precision, Low Drift, Audio, Mic Pre Amp, THD+N = 0.09% SSM2017 Replacement	1 to 10000	0.00063	12000	300	1.2 <sup>3</sup>	100	800	1.3	±4.5 to ±18	12	DIP-8, SO-16	\$2.50

<sup>1</sup> Internal +40V input protection.

<sup>2</sup> Parts also available in dual version.

<sup>3</sup> Typical.

\* Suggested resale price in U.S. dollars in quantities of 1,000.

Programmable gain instrumentation amplifiers (PGAs) are extremely versatile data acquisition input amplifiers that provide digital control of gain for improved accuracy and extended dynamic range. Many have inputs that are protected to  $\pm 40V$  even with the power supply off. A single input amplifier type can be connected to a variety of sensors or signals. Under processor control, the switched gain extends the dynamic range of the system.

All PGA-series amps have TTL- or CMOS-compatible inputs for easy microprocessor interface. Inputs are laser trimmed for low offset voltage and low drift to allow use without the need of external components.

### Design Considerations

#### Primary

**Digitally-selected gain required**—two pins allow the selection of up to four different gain states. A PGA202 and PGA203 can be put in series for greater gain selection.

**Non-linearity (accuracy)**—depends heavily on what is being driven. A 16-bit converter will require significantly better accuracy (i.e., lower non-linearity) than a 10-bit converter.

#### Secondary

**Gain error and drift**—for higher gain, high-precision applications will require closer attention to drift and gain error.

**Input bias current**—high source impedance applications often require FET-input amps to minimize bias current errors.

#### Technical Information

The PGA206 provides binary gain steps of 1, 2, 4 and 8V/V, selected by CMOS- or TTL-compatible inputs. The PGA207 has gains of 1, 2, 5 and 10V/V, adding a full decade to the system dynamic range. The low input bias current, FET-input stage assures that series resistance of the multiplexer does not introduce errors. Fast settling time (3.5 $\mu$ s to 0.01%) allows fast polling of many channels.

## Programmable Gain Amplifiers



The PGA204 and PGA205 have precision bipolar input stages especially well suited to low-level signals. The PGA205 has gain steps of 1, 2, 4 and 8.

#### Typical Applications

- Data acquisition
- Auto-ranging circuits
- Remote instrumentation
- Test equipment
- Medical/physiological instrumentation
- General analog interface boards

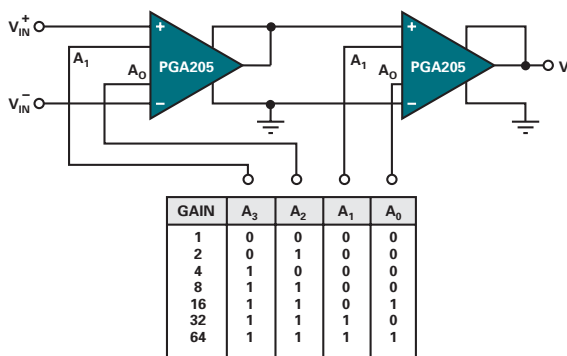

Connecting two programmable gain amps can provide binary gain steps  $G = 1$  to  $G = 64$ .

## Digitally Programmable Gain Amplifiers Selection Guide

Device	Description	Gain	Non Linearity at G = 100 (%) (max)	Offset (μV) (max)	Offset Drift (μV/°C) (max)	CMRR at G = 100 (dB) (min)	BW at G = 100 (kHz) (typ)	Noise at 1kHz (nV/√Hz) (typ)	Power Supply (V)	I <sub>Q</sub> (mA) (max)	Package(s)	Price*
PGA103	Precision, Single-Ended Input	1, 10, 100	0.01	500	2 (typ)	—	250	11	$\pm 4.5$ to $\pm 18$	3.5	SOIC-8	\$4.35
PGA202	High Speed, FET-Input, 50pA I <sub>B</sub>	1, 10, 100, 1000	0.012	1000	12	92	1000	12	$\pm 4.5$ to $\pm 18$	6.5	DIP-14	\$7.75
PGA203	High Speed, FET-Input, 50pA I <sub>B</sub>	1, 2, 4, 8	0.012	1000	12	92	1000	12	$\pm 4.5$ to $\pm 18$	6.5	DIP-14	\$7.75
PGA204	High Precision, Gain Error: 0.25%	1, 10, 100, 1000	0.002	50	0.25	110	10	13	$\pm 4.5$ to $\pm 18$	6.5	SOIC-16, PDIP-16	\$7.25
PGA205	Gain Drift: 0.024ppm/°C	1, 2, 4, 8	0.002	50	0.25	95	100	15	$\pm 4.5$ to $\pm 18$	6.5	SOIC-16, PDIP-16	\$7.25
PGA206	High Speed, FET-Input, 100pA I <sub>B</sub>	1, 2, 4, 8	0.002	1500	2 (typ)	95	600	18	$\pm 4.5$ to $\pm 18$	13.5	DIP-16, SOIC-16	\$10.80
PGA207	High Speed, FET-Input, 100pA I <sub>B</sub>	1, 2, 5, 10	0.002	1500	2 (typ)	95	600	18	$\pm 4.5$ to $\pm 18$	13.5	DIP-16, SOIC-16	\$11.85
<b>PGA309</b>	0.1% Digitally Calibrated Bridge Sensor Conditioner, Voltage Output	8 to 11	0.01	3000	5 (typ)	20	60	210	+2.7 to +5.5	1.6	TSSOP-16	\$2.95

\*Suggested resale price in U.S. dollars in quantities of 1,000.

New products are listed in bold red.

## → Voltage-Controlled Gain Amplifiers

The voltage-controlled gain amplifier (VCA) provides linear dB gain and gain-range control with high impedance inputs. Available in single, dual and octal configurations, the VCA series is designed to be used as a flexible gain-control element in a variety of electronic systems. With a broad gain-control range, both gain and attenuation control are provided for maximum flexibility.

### Design Considerations

#### Primary

- Input frequency
- Noise ( $nV/\sqrt{Hz}$ )
- Variable gain range

#### Secondary

- Number of channels
- Distortion—low second harmonic and third harmonic distortion
- Level of integration
- Per channel power consumption

### Technical Information

The broad attenuation range can be used for gradual or controlled channel turn-on or turn-off where abrupt gain changes can create artifacts and other errors.

### Typical Applications

- Ultrasound systems
- Medical and industrial
- Test equipment

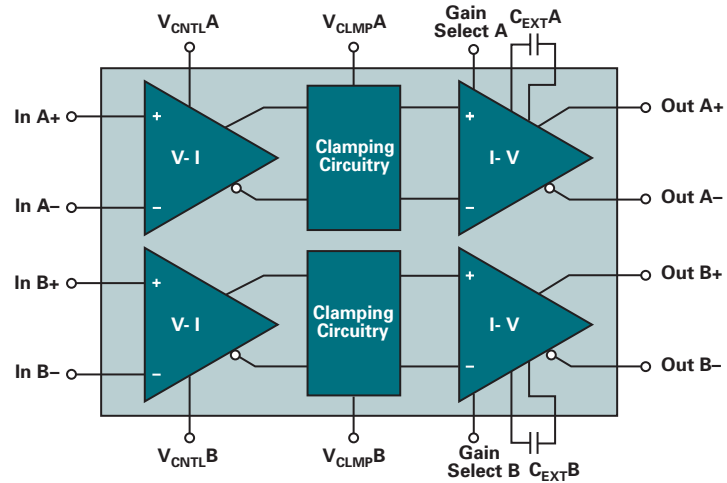

VCA2617 functional block diagram.

## Two-Channel Variable Gain Amplifier

### VCA2615

Get samples, datasheets, EVMs and app reports at: [www.ti.com/sc/device/VCA2615](http://www.ti.com/sc/device/VCA2615)

### Key Features

- Ultra-low noise LNP:  $0.7nV/\sqrt{Hz}$
- Programmable LNP gains
- Buffered LNP outputs for CW
- VGA gain control range: 52dB
- Linear control response: 22dB/V
- Adjustable output clipping
- Bandwidth: 42MHz
- Single supply: 5V
- Packaging: Small QFN-48 (7x7)

The VCA2615 is a two-channel variable gain amplifier well suited to high-end ultrasound systems. Excellent performance enables use in high-performance applications. Each channel consists of a programmable low noise preamplifier (LNP) and a variable gain amplifier (VGA).

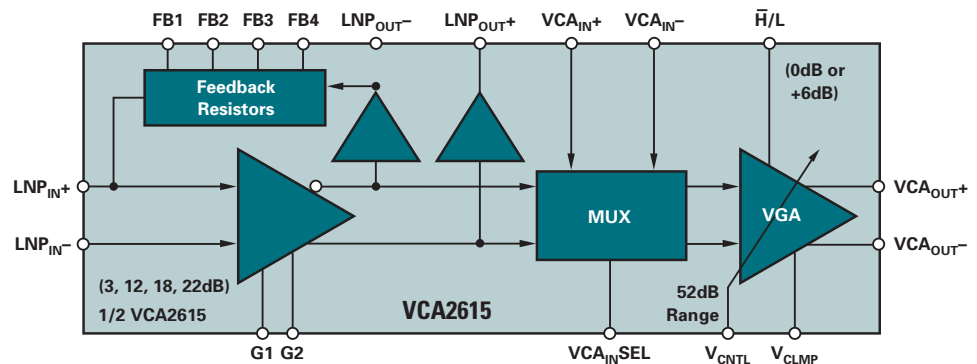

VCA2615 functional block diagram.



## 8-Channel Variable Gain Amplifier

### VCA8617

Get samples, datasheets, EMVs and app reports at: [www.ti.com/sc/device/VCA8617](http://www.ti.com/sc/device/VCA8617)

#### Key Features

- Low noise LNA:  $1.0\text{nV}/\sqrt{\text{Hz}}$
- Low-power:  $103\text{mW}/\text{channel}$
- Integrated input clamp diodes
- Integrated continuous wave (CW) switch matrix
- Programmable gain and attenuator settings
- Serial data port
- Integrated 2-pole low-pass filter
- Differential outputs
- Single supply:  $3\text{V}$

The VCA8617 is an 8-channel LNA and VCA with integrated CW switch matrix circuitry and low-pass filtering. This high level of integration reduces cost and lessens the need for external circuitry.

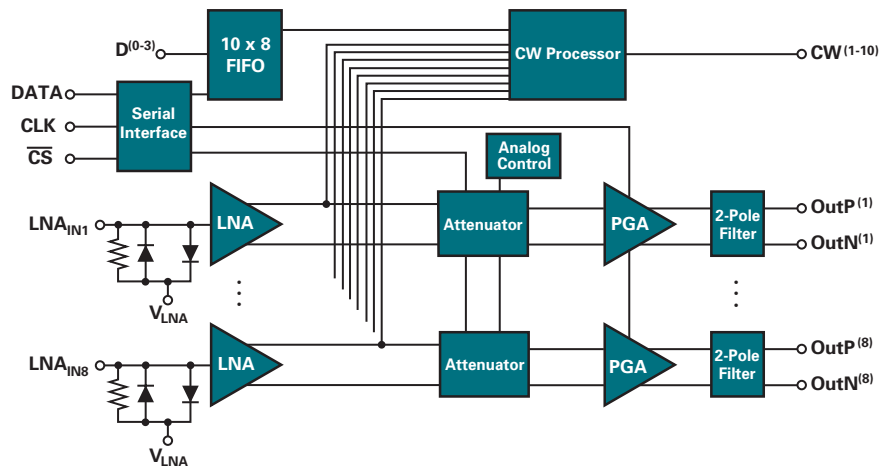

The VCA8617 is an 8-channel variable gain amplifier well suited for portable ultrasound applications.

## Voltage-Controlled Gain Amplifiers Selection Guide

Device	$V_N$ ( $\text{nV}/\sqrt{\text{Hz}}$ )	Bandwidth (MHz) (typ)	Specified at $V_S$ (V)	Number of Channels	Variable Gain Range (dB)	Package	Price*
VCA2612	1.25	40	5	2	45	TQFP-48	\$12.50
VCA2613	1	40	5	2	45	TQFP-48	\$10.25
VCA2614	4.8	40	5	2	40	TQFP-32	\$8.35
VCA2616/2611	1	40	5	2	45	TQFP-48	\$10.25
VCA810	2.4	30	$\pm 5\text{V}$	1	80	SO-8	\$5.75
VCA2618	5.5	40	5	2	45	TQFP-32	\$8.40
THS7530	1.27	300	5	1	46	HTSSOP-14	\$3.65
VCA8613	1.2	14	3	8	40	TQFP-64	\$25.40
VCA2619	5.9	40	5	2	50	TQFP-32	\$8.40
<b>VCA2615</b>	0.7	42	5	2	52	QFN-48	\$10.25
<b>VCA2617</b>	3.8	50	5	2	48	QFN-32	\$8.40
VCA8617	1	15	3	8	40	TQFP-64	\$24.00

\*Suggested resale price in U.S. dollars in quantities of 1,000.

New products are listed in bold red.





## Audio Amplifiers

Consumers are enjoying new ways to listen to music, books and news, while demanding more flexibility, better quality and multifunctional products. There is an ever-increasing demand for high-end entertainment for the everyday consumer. The market expects the best listening experience from any audio format and source, mobile or stationary and at a competitive price.

By offering flexible, cost-efficient, end-to-end audio solutions, TI provides OEMs and ODMs with faster time-to-market and one-stop shopping. TI's complete audio solutions include best-in-class silicon, systems expertise, software and support. By leveraging the programmability, performance headroom and design flexibility of TI's leading DSP and analog technologies, customers have the ability to build audio products with more functionality that offer a true, lifelike sound experience at a lower overall system cost.

### Design Considerations

#### Primary

**Output power**—supply voltage and load impedance limit the level of output power (i.e., volume) an audio power amp (APA) can drive. Always verify that the desired output power is theoretically possible with the equation: where  $V_O$  is the RMS voltage of the output signal and  $R_L$  is the load impedance.

$$P_O = \frac{V_O^2}{R_L}$$

**Output configuration**—there are two types of output configurations, single-ended (SE) and bridge-tied load (BTL). An SE configuration is where one end of the load is connected to the APA and the other end of the load is connected to ground. Used primarily in headphone applications or where the audio power amplifier and speaker are in different enclosures. A BTL configuration is where both ends of the load are connected to an APA. This configuration effectively quadruples the output power capability of the system

### TI's New Audio Quick Search Tools!

On TI's Audio Home Page, we have added a great new feature! Our Audio Quick Search Tool allows you to easily find the Audio device based on your design specifications. It's easy to use, just go to [www.ti.com/audio](http://www.ti.com/audio) and select one of the available tools, such as Audio Amplifiers, Converters or CODECs. Select your options and the suggested device will take you directly to the product folder.

[www.ti.com/audio](http://www.ti.com/audio)

and is used primarily in applications that are space constrained and where the APA and speaker are in the same enclosure.

**Total Harmonic Distortion + Noise (THD+N)**—harmonic distortion is distortion at frequencies that are whole number multiples of the test tone frequency. THD+N is typically specified for rated output power at 1kHz. Values below 0.5 percent to 0.3 percent are negligible to the untrained ear.

**Amplifier technology (Class-D and Class-AB)**—Class-D and Class-AB are the most common APAs in consumer electronics, because of their great performance and low cost. Class-D amps are very efficient and provide the longest battery life and lowest heat dissipation. Class-AB amps offer the greatest selection of features (e.g., digital volume control and bass boost).

#### Secondary

**Digital volume control**—this input changes the gain of the APA when digital high or low pulses are applied to the UP and DOWN pins of the device.

**DC volume control**—internal gain settings that are controlled by DC voltage applied to the VOLUME pin of the IC.

**Integrated gain settings**—the internal gain settings are controlled via the input pins, GAIN<sub>0</sub> and GAIN<sub>1</sub>, of the IC.

**DEPOP**—circuitry internal to the APA. It minimizes voltage spikes when the APA turns on, off, or transitions in or out of shutdown mode.

**MUX**—allows two different audio sources to the APA that are controlled independently of the amplifier configuration.

**Shutdown**—circuitry that places the APA in a very low power consumption standby state.

#### Technical Information

TI APAs are easy to design with, requiring only a few external components.

**Power supply capacitors**— $C_{VDD}$  minimizes THD by filtering off the low frequency noise and the high frequency transients.

**Input capacitors**—in the typical application,  $C_{IN}$  is required to allow the amplifier to bias the input signal to the proper dc level for optimum operation.  $C_{IN}$  is usually in the 0.1µF to 10µF range for good low-frequency response.

**Bypass capacitor**— $C_{BYPASS}$  controls the start up time and helps to reduce the THD. Typically, this capacitor is ten times larger than the input decoupling capacitors ( $C_{IN}$ ).

**Layout**—by respecting basic rules, Class-D amplifiers layout can be made easy. Decoupling caps must be close to the device, the output loop must be small to avoid the use of a filter and the differential input traces must be kept together to limit the RF rectification. Analog  $V_{DD}$  and switching  $V_{DD}$  need to be separated back to supply source.

**Migration path**—APA products are in a constant evolution moving from Class-AB mono speaker drivers to optimized stereo Class-D amplifiers with advanced features. The latest generation is the most cost effective for the application.

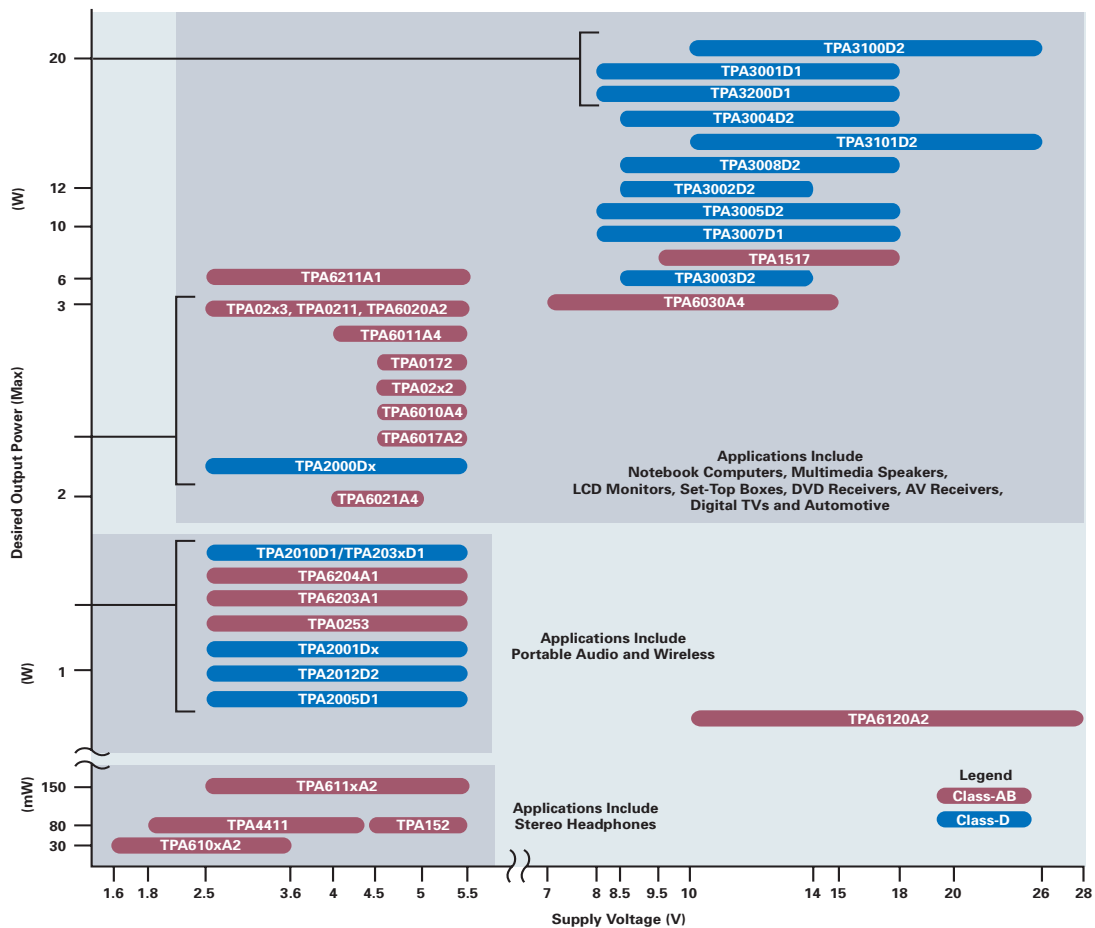
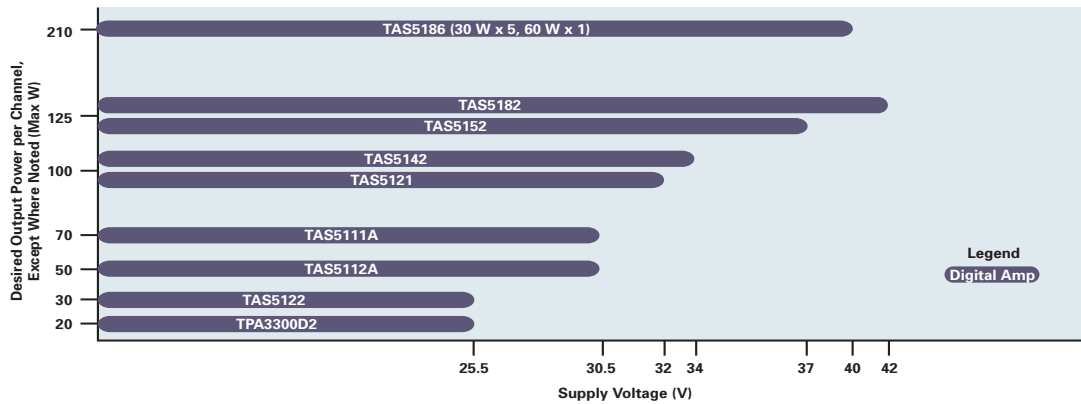

### Audio Power Amplifiers – Packaging

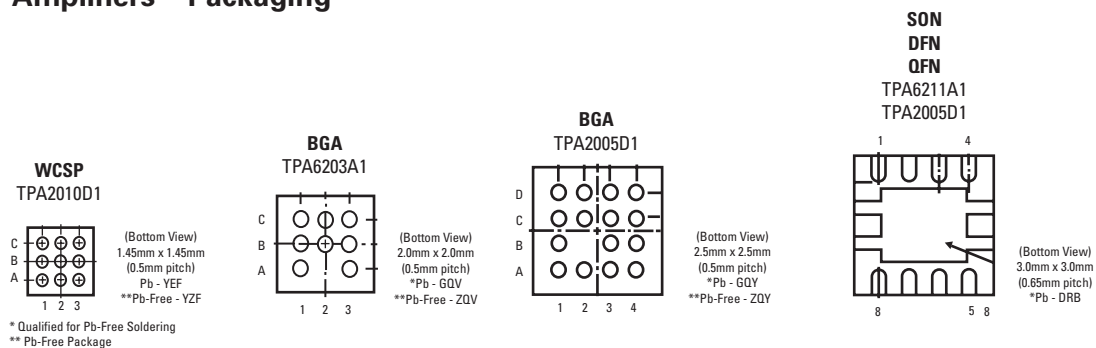

## → Audio Amplifiers

### Audio Power Amplifiers

Device	Description	Stereo/ Mono Speaker Drive	Stereo/ Mono Head- phone Drive	Output Power (W)	Power Supply (min) & (max) (V)	Half Power THD+N at 1kHz (%)	PSRR (dB)	I <sub>Q</sub> Per Channel (typ) (mA)	I <sub>SD</sub> (μA)	Min. Load Impe- dance (Ω)	Depop	Mute	Shut- down (Active Low/ High)	Internal Gain	DC Volume Control	Package(s)	Package Symbolization	Price*
<b>Class-D Stereo</b>																		
TPA3004D2	Stereo, High Power, Class-D with Volume Control	S	—	12	8.5 18	0.1	80	8.0	1	4	✓	—	L	—	✓	QFP	TPA3004D2	\$3.25
TPA3005D2	Stereo, Medium Power, Class-D	S	—	6	8 18	0.1	80	10.0	1	8	✓	—	L	✓	—	QFP	TPA3005D2	\$2.95
TPA3003D2	Stereo, Low Power, Class-D	S	—	3	8.5 14	0.2	80	10.0	1	8	✓	—	L	—	✓	QFP	TPA3003D2	\$3.00
TPA2008D2	Stereo, High Power, 5V, Filter-Free Class-D with Volume Control	S	—	3	4.5 5.5	0.05	70	7.0	0.05	3	✓	—	L	—	✓	TSSOP	TPA2008D2	\$1.80
TPA3002D2	Stereo, Medium Power Class-D with Volume Control	S	—	9	8.5 14	0.06	80	10.0	1	8	✓	—	L	—	✓	QFP	TPA3002D2	\$3.30
TPA2000D4	Stereo Filter-Free Class-D with Stereo Class-AB Headphone Drive	S	S	2.5	3.7 5.5	0.1	70	4.5	0.05	4	✓	—	L	✓	—	TSSOP	TPA2000D4	\$1.65
TPA2000D2	Stereo Filter-Free Class-D	S	—	2.5	4.5 5.5	0.05	77	4.0	1	3	✓	—	L	✓	—	TSSOP	TPA2000D2	\$1.45
TPA2001D2	Stereo Filter-Free Class-D	S	—	1.25	4.5 5.5	0.08	77	4.0	1	8	✓	—	L	✓	—	TSSOP	TPA2001D2	\$1.20
TPA2012D2	Stereo, Class-D Amplifier	S	—	2.1	2.5 5.5	0.2	75	2.5	0.5	4	✓	—	L	✓	—	WCSP QFN	AKR AKS	\$1.05 \$0.95
TPA3008D2	Stereo, Class-D Amplifier	S	—	10	8.5 18	0.1	80	11	1.6	8	✓	—	L	✓	—	HTQFP	TPA3008D2	\$3.10
<b>TPA3100D2</b>	20W Stereo, Wide Supply Voltage, Class-D Audio	S	—	20	10 26	0.1	70	11	180	4	✓	✓	L	✓	—	HTQFP	TPA3100D2	\$3.50
<b>TPA3101D2</b>	10W Stereo, Wide Supply Voltage Class-D Audio	S	—	10	10 26	0.1	70	11	300	4	✓	✓	L	✓	—	QFN, QFP	TPA3101D2	\$3.10
<b>Class-D Mono</b>																		
TPA3001D1	Mono, High Power, Class-D	M	—	20	8 18	0.06	73	8.0	1	4	✓	—	L	✓	—	TSSOP	TPA3001D1	\$2.50
TPA3007D1	Mono, Medium Power, Class-D	M	—	6.5	8 18	0.2	73	8.0	1	7	✓	—	L	✓	—	TSSOP	TPA3007D1	\$1.95
TPA2010D1	Mono, Fully Differential, Filter-Free Class-D in WCSP	M	—	2.5	2.5 5.5	0.2	75	2.8	0.5	4	✓	—	L	—	—	WCSP	AJZ(Pb), AKO(Pb-Free)	\$0.55
<b>TPA2032D1</b>	Mono, Fully Differential, Filter-Free Fixed Gain of 2V/V	M	—	2.1	2.5 5.5	0.2	75	3.0	0.5	4	✓	—	L	✓	—	WCSP	2032 = BPX, 2033 = BPY, 2034 = BPZ (all Pb-Free)	\$0.60
<b>TPA2033D1</b>	Mono, Fully Differential, Filter-Free Fixed Gain of 3V/V																	
<b>TPA2034D1</b>	Mono, Fully Differential, Filter-Free Fixed Gain of 4V/V																	
TPA2000D1	Mono Filter-Free Class-D	M	—	2.7	2.7 5.5	0.08	77	4.0	0.05	4	✓	—	L	✓	—	TSSOP	TPA2000D1	\$1.05
TPA2005D1	Mono, Fully Differential, Filter-Free Class-D	M	—	1.4	2.5 5.5	0.2	75	2.8	0.5	8	✓	—	L	—	—	MicroStar Jr.™ BGA QFN, MSOP	PB051 (Pb) AAFI (Pb-Free) BIQ, BAL	\$0.49
TPA2001D1	Mono Filter-Free Class-D	M	—	1.25	2.7 5.5	0.2	72	4.0	0.05	8	✓	—	L	✓	—	TSSOP	TPA2001D1	\$0.75
TPA3200D1	Mono, High Power, Digital Input, Class-D Audio Amplifier	M	—	20	8 18	0.1	73	8	1	4	✓	✓	L	✓	—	TSSOP	TPA3200D1	\$2.95
<b>Class-AB Stereo</b>																		
TPA1517	Stereo, Medium Power, Class-AB	S	—	6	9.5 18	0.15	65	22.5	7	4	✓	✓	—	✓	—	SOIC, DIP	TPA1517	\$0.85
TPA6030A4	Wide Supply Voltage, Low Power, Class-AB	S	S	3	7 15	0.06	60	18	1	16	✓	—	L	—	✓	TSSOP	TPA6030A4	\$1.40
TPA6017A2	Stereo, Cost-Effective, Class-AB	S	—	2.6	4.5 5.5	0.1	77	3.0	150	3	✓	—	L	✓	—	TSSOP	TPA6017A2	\$0.99
TPA6011A4	Stereo, Class-AB with Volume Control & Stereo Headphone Drive	S	S	2.6	4.0 5.5	0.06	70	3.8	1	3	✓	—	L	—	✓	TSSOP	TPA6011A4	\$1.20
TPA6010A4	Stereo Class-AB with Stereo Headphone Drive, Volume Control and Bass Boost	S	S	2.6	4.5 5.5	0.06	67	6.0	60	3	✓	—	L	—	✓	TSSOP	TPA6010A4	\$2.25
TPA0252	Stereo Class-AB with Stereo Headphone Drive, Volume Control Memory	S	S	2.8	4.5 5.5	0.06	67	4.5	150	3	✓	—	L	—	✓	TSSOP	TPA0252	\$1.80
TPA0212	Stereo Class-AB with Stereo Headphone Drive and Integrated Gain	S	S	2.6	4.5 5.5	0.15	77	3.0	150	3	✓	—	L	✓	—	TSSOP	TPA0212	\$1.10

\*Suggested resale price in U.S. dollars in quantities of 1,000.

New products are listed in bold red. Preview products are listed in bold blue.



## Audio Power Amplifiers

Device	Description	Stereo/ Mono Speaker Drive	Stereo/ Mono Head- phone Drive	Output Power (W)	V <sub>CC</sub> / V <sub>DD</sub> (min) & (max) (V)	Half Power THD+N at 1kHz (%)	PSRR (dB)	I <sub>Q</sub> Per Channel (typ) (mA)	I <sub>SD</sub> (μA)	Min. Load Impe- dance (Ω)	Depop	Mute	Shut- down (Active Low/ High)	Internal Gain	DC Volume Control	Package(s)	Package Symbolization	Price <sup>*</sup>
<b>Class-AB Stereo (Continued)</b>																		
TPA0172 <sup>1</sup>	Stereo Class-AB with Stereo Headphone Drive & I <sup>2</sup> C Control	S	S	2.0	4.5 5.5	0.08	75	4.0	15	4	✓	✓	L	✓	—	TSSOP	TPA0172	\$2.45
TPA6112A2	Stereo, Differential Input, Headphone	—	S	0.15	2.5 5.5	0.25	83	0.75	10	8	✓	—	H	—	—	MSOP	APD	\$0.39
TPA6111A2	Stereo Headphone, Pin Compatible with LM4880 and LM4881	—	S	0.15	2.5 5.5	0.25	83	0.75	1	8	✓	—	H	—	—	SOIC MSOP	TPA6111A2 AJA	\$0.29
TPA6110A2	Stereo Headphone, Pin Compatible with LM4881	—	S	0.15	2.5 5.5	0.25	83	0.75	10	8	✓	—	H	—	—	MSOP	AIZ	\$0.39
TPA152	Hi-Fi, Stereo Headphone	—	S	0.075	4.5 5.5	0.007	81	2.8	—	32	✓	✓	—	—	—	SOIC	TPA152	\$0.55
TPA6102A2	Ultra Low Voltage, Stereo Headphone with Fixed Gain (14dB)	—	S	0.05	1.6 3.6	0.1	72	0.32	0.05	16	✓	—	L	✓	—	SOIC MSOP	TPA6102A2 AJN	\$0.35
TPA6101A2	Ultra Low Voltage, Stereo Headphone with Fixed Gain (2dB)	—	S	0.05	1.6 3.6	0.1	72	0.32	0.05	16	✓	—	L	✓	—	SOIC MSOP	TPA6101A2 AJM	\$0.35
TPA6100A2	Ultra Low Voltage Stereo Headphone	—	S	0.05	1.6 3.6	0.1	72	0.38	0.05	16	✓	—	L	—	—	SOIC MSOP	TPA6100A2 AJL	\$0.35
TPA4411	Cap-Free Stereo Headphone Amplifier	—	S	0.08	1.8 4.5	0.08	80	3.5	0.1	16	✓	—	L	✓	—	WCSP QFN	AKT AKQ	\$0.70
TPA6120A2	High-Fidelity Stereo Headphone Driver	—	S	1.5	10 30	0.0005	75	11.5	—	32	—	—	—	—	—	HSOP	TPA6120A2	\$1.90
TPA6021A4	Stereo, Class-AB Audio Amplifier with Volume Control and Stereo Headphone Drive	S	S	2	4 5.5	0.19	70	7.5	1	4	✓	—	L	—	✓	PDIP	TPA6021A4	\$1.00
TPA6020A2	Stereo, Fully Differential Class-AB Audio Amplifier	S	—	2.8	2.5 5.5	0.05	85	8	0.05	3	✓	—	L	—	—	QFN	TPA6020A2	\$1.15
<b>Class-AB Mono</b>																		
TPA6211A1	High Power, 5V Mono, Class-AB, Fully Differential	M	—	3.1	2.5 5.5	0.05	85	4.0	0.01	3	✓	—	L	—	—	MSOP QFN	AYK AYN	\$0.55
TPA0233	Mono Class-AB with Stereo Headphone Drive—Summed Inputs	M	S	2.7	2.5 5.5	0.06	75	3.3	1	4	✓	—	L	—	—	MSOP	AEJ	\$1.15
TPA0213	Mono Class-AB with Stereo Headphone Drive—Separate Inputs	M	S	2.7	2.5 5.5	0.06	75	3.6	1	4	✓	—	L	—	—	MSOP	AEH	\$1.15
TPA0211	Mono Class-AB with Mono Headphone Drive	M	M	2.7	2.5 5.5	0.06	75	4.0	1	4	✓	—	L	—	—	MSOP	AEG	\$0.70
TPA6203A1	Mono, Fully Differential, Class-AB	M	—	1.5	2.5 5.5	0.06	85	1.7	0.01	8	✓	—	L	—	—	MicroStar Jr.™ BGA	AADI (Pb) AAEI (Pb-Free)	\$0.45
TPA0253	Mono, Low Power, Class-AB with Stereo Headphone Drive—Summing Inputs	M	S	1.25	2.5 5.5	0.1	75	2.7	1	8	✓	—	L	—	—	MSOP	AEL	\$0.60
TPA751	Mono, Differential Input, Class-AB with Active Low Shutdown	M	—	0.9	2.5 5.5	0.15	78	1.25	0.0015	8	—	—	L	—	—	SOIC MSOP	TPA751 ATC	\$0.35
TPA741	Mono, Differential Input, Class-AB with Active High Shutdown and Depop	M	—	0.9	2.5 5.5	0.15	85	1.35	7	8	✓	—	H	—	—	SOIC MSOP	TPA741 AJD	\$0.35
TPA731	Mono, Differential Input, Class-AB with Active High Shutdown	M	—	0.9	2.5 5.5	0.15	78	1.25	0.0015	8	—	—	H	—	—	SOIC MSOP	TPA731 AJC	\$0.35
TPA721	Mono Class-AB with Active High Shutdown	M	—	0.9	2.5 5.5	0.15	85	1.25	7	8	✓	—	H	✓	—	SOIC MSOP	TPA721 ABC	\$0.35
TPA711	Mono Class-AB with Mono Headphone Drive	M	M	0.9	2.5 5.5	0.15	85	1.25	7	8	✓	—	H	—	—	SOIC MSOP	TPA711 ABB	\$0.35
TPA6204A1	Mono Class-AB Amplifier	M	—	1.7	2.5 5.5	0.05	85	4.0	0.01	8	✓	—	L	—	—	QFN	AYJ	\$0.50

<sup>1</sup>Includes digital volume control. \*Suggested resale price in U.S. dollars in quantities of 1,000.



## Audio Amplifiers

### PurePath Digital™ PWM Processors

Device	Channels	Sampling Frequency	Dynamic Range	Audio Controls	THD+N (% System Performance)	Bits	Package	Price*
TAS5010	2	32 to 192	96	Modulator Only	< 0.08	16, 20, 24	QFP	\$3.00
TAS5012	2	32 to 192	102	Modulator Only	< 0.08	16, 20, 24	QFP	\$3.50
TAS5504A	4	32 to 192	102	Volume, Audio Filters	< 0.1	16, 20, 24	QFP	\$4.30
TAS5508B	8	32 to 192	100	Volume, Audio Filters	< 0.1	16, 20, 24	QFP	\$5.00
TAS5086	6	32 to 192	100	Volume, Bass Mgmt., Audio Filters	< 0.1	16, 20, 24	TSSOP	\$1.60
TAS5518	8	32 to 192	110	Volume, Bass Mgmt.	< 0.1	16, 20, 24	QFP	\$7.95

### PurePath Digital™ Power Stages

Device	Output Power	Power Supply (V)		Channels	THD+N at 1W	Package(s)	Price*
		(min)	(max)				
TAS5111A	70W (4Ω)	16	30.5	1	0.025	32 PowerPAD™, TSSOP	\$2.40
TAS5112A	50W (6Ω)	16	30.5	2	0.025	56 PowerPAD, TSSOP	\$4.00
TAS5121	100W (4Ω)	10.8	32	1	0.05	36 PSOP, SSOP	\$3.00
TAS5122	30W (6Ω)	16	25.5	2	0.05	56 PowerPAD, TSSOP	\$3.15
TAS5142	100W (4Ω)	10.8	34	2	0.1	36 SSOP	\$3.30
TAS5152	125W (4Ω)	10.8	37	2	0.1	36 SSOP, TSSOP	\$4.30
TAS5182	100W (6Ω)	9	42	2	0.15	56 PowerPAD, TSSOP	\$5.30
TAS5186A	30/60W (6/3Ω)	10.8	40	6	0.07	44 PowerPAD, 36 PSOP	\$5.10

### Microphone Preamplifiers

Device	Description	Gain Range (dB)	Noise ( $E_{IN}$ , G = 30dB)	THD+N with Gain = 30dB (%)	Power Supply (V)	Package(s)	Price*
PGA2500	Digitally Controlled Mic Preamp	0dB, and 10dB to 65dB in 1dB steps	-128dBu	0.0004	±5	SSOP-28	\$9.95

\*Suggested resale price in U.S. dollars in quantities of 1,000.

## Digitally Controlled Microphone Preamplifier

### PGA2500

Get samples and datasheets at: [www.ti.com/sc/device/PGA2500](http://www.ti.com/sc/device/PGA2500)

#### Key Features

- 0dB, 10dB to 65dB in 1dB steps
- Fully differential I/O
- Dynamic performance
  - Equivalent input noise of -128dBu with  $Z_S = 150\Omega$ ; Gain = 30dB
  - THD+N of 0.0004% with Gain = 30dB
- Includes DC servo
- Common-mode servo improves CMRR
- Four general-purpose digital outputs
- Serial interface
- ±5V supply
- Packaging: 28-lead SSOP

#### Applications

- Microphone preamplifiers and mixers
- Digital mixers and recorders

The PGA2500 is a digitally controlled, analog microphone preamplifier designed for use as a front end for high-performance audio ADCs. The PGA2500 features include low noise, wide dynamic range and a differential signal path. An on-chip DC servo loop is employed to minimize DC offset, while a common-mode servo function may be used to enhance common-mode rejection.

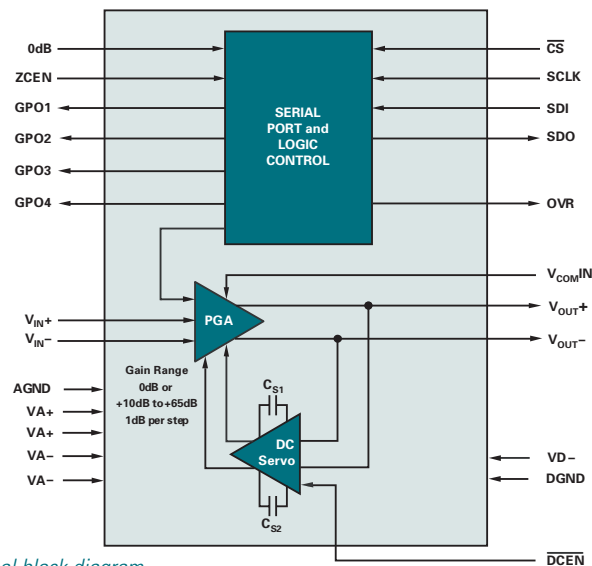

PGA2500 functional block diagram.



## Power Amplifiers and Buffers



TI power amplifiers solve tough high-voltage and high-current design problems in applications requiring up to 80V and 10A output current. Most are internally protected against thermal and current overload, and some offer user-defined current limiting. The unity-gain buffer amplifier series provides slew rates up to 3600V/ $\mu$ s and output current to 250mA.

### Design Considerations

**Power dissipation**—determines the appropriate package type as well as the size of the required heat sink. Always stay within the specified operating range to maintain reliability of the power amps. Some power amps are internally protected against overheating and overcurrent. The thermally-enhanced PowerPAD™ package provides greater design flexibility and increased thermal efficiency in a standard size IC

package. PowerPAD provides an extremely low thermal resistance path to a ground plane or special heatsink structure.

**Full-power bandwidth**—or large-signal bandwidth, high FPBW is achieved by using power amps with high slew rate.

**Current limit**—be aware of the specified operating area, which defines the relationship between supply voltage and current output. Both power supply and load must be appropriately selected to avoid thermal and current limits.

**Thermal shutdown**—the incorporation of internal thermal sensing and shut-off will automatically shut-off the amplifier should the internal temperature reach a specified value.

### Technical Information Power Amps

Unlike other designs using a power resistor in series with the output current path, the OPA547, OPA548 and OPA549 power amps sense current internally. This allows the current limit to be adjusted from near 0A to the upper limit with a control signal or a low-power resistor. This feature is included in the OPA56x series. The new 2A OPA567 comes in the tiny QFN package.

### Buffer

The BUF634 can be used inside the feedback loop to increase output current, eliminate thermal feedback and improve capacitive load drive. When connected inside the feedback loop, the offset voltage and other errors are corrected by the feedback of the op amp.

## Function-Integrated, Rail-to-Rail I/O Power Amplifier

### OPA569

**NEW**

Get samples and datasheets at: [www.ti.com/sc/device/OPA569](http://www.ti.com/sc/device/OPA569)

### Key Features

- High output drive: 2A
- Rail-to-rail input/output
- Single-supply operation: 2.7V to 5.5V
- Thermal protection, temperature warning flag
- Current limit, current monitor pin
- Shutdown with output disable
- Packaging: SO-20

### Applications

- Laser diode pump driver
- Valve, actuator driver
- Synchro, servo driver
- Transducer excitation
- General linear power booster for op amps
- Paralleling option for higher current applications

The OPA569 integrates a single-supply, high-current operational amplifier design with internally integrated thermal and current monitoring functions. The OPA569 output can swing within 150mV of supply rails while driving 2A of continuous output current, and maintains excellent performance under heavy loading. Integrated features include a unique output topology designed for parallel output, enabling the two OPA569 devices to drive up to 4A of current on a single supply. Additional monitoring features include current monitor pin and resistor-set current limit, as well as an over temperature threshold pin. The OPA569 is specified from  $-40^{\circ}\text{C}$  to  $+85^{\circ}\text{C}$  and is packaged in a small SO-20 PowerPAD™ package.

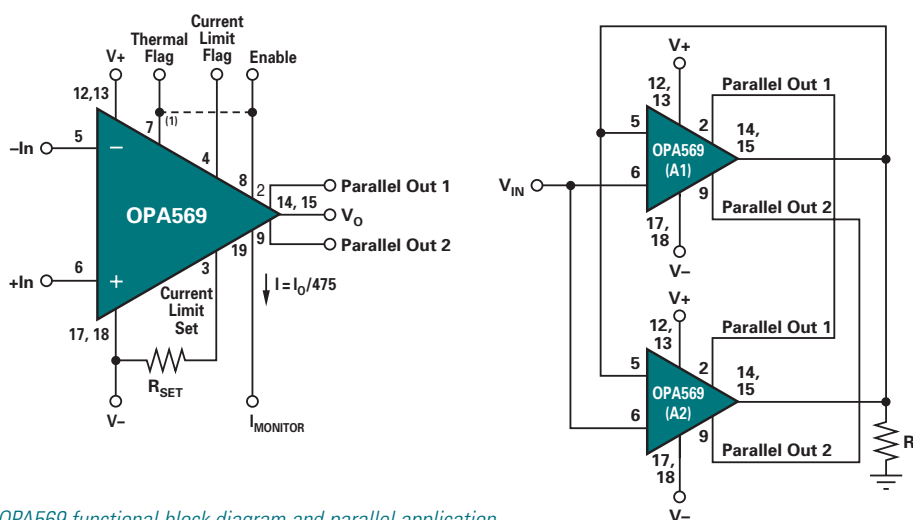

OPA569 functional block diagram and parallel application.

## Power Amplifiers and Buffers

### High-Performance, Closed-Loop, Wideband, Unity Gain Buffer

#### BUF602

NEW

Get samples, datasheets and app reports at: [www.ti.com/sc/device/BUF602](http://www.ti.com/sc/device/BUF602)

#### Key Features

- Small signal bandwidth: 1000MHz
- Very high slew rate: 8000V/ $\mu$ s
- High FPBW: 880MHz for 5Vpp
- Low supply current: 5.8mA
- Closed-loop design
- Low output impedance (1.4 $\Omega$  typ)
- Flexible supply range:
  - $\pm 1.4$ V to  $\pm 6.3$ V dual supply
  - +2.8V to +12.6V single supply

#### Applications

- High CMRR ADC drivers
- Negative impedance converter filters
- Simple, wideband video buffers
- Flexible diode drivers
- Medical imaging

By using a closed-loop design, the BUF602 provides a very low output impedance through high frequencies using a low 5.8mA quiescent current. An optional feature has been added to benefit single-supply operation. A second very low power buffer takes a mid-supply reference developed through two 50k $\Omega$  resistors and drives this reference out through an internal 200 $\Omega$  resistor. This feature provides an approximate mid-supply DC operating point for the high-speed buffer in AC-coupled, single-supply applications.

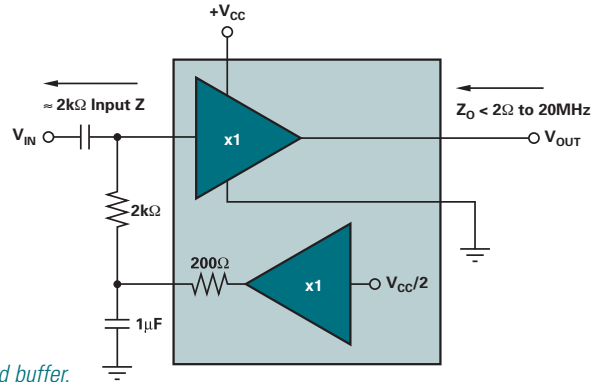

Single-supply, wideband buffer.

### Power Amplifiers Selection Guide

Device	I <sub>OUT</sub> (A)	V <sub>S</sub> (V)	Bandwidth (MHz)	Slew Rate (V/ $\mu$ s)	I <sub>Q</sub> (mA) (max)	V <sub>OS</sub> (mV) (max)	V <sub>OS</sub> Drift ( $\mu$ V/ $^{\circ}$ C) (max)	I <sub>B</sub> (nA) (max)	Package(s)	Price*
OPA445/B	0.015	20 to 90	2	15	4.7	5	10	0.1	DIP8, SO8	\$4.75
OPA452	0.05	20 to 80	1.8	8	6.5	3	5	0.1	TO220-7, DDPak-7	\$2.55
OPA453	0.05	20 to 80	7.5	20	6.5	3	5	0.1	TO220-7, DDPak-7	\$2.55
OPA541	10	20 to 80	0.055	6	25	10	40	0.05	ZIP-11	\$11.10
OPA544	4	20 to 70	1.4	8	15	5	10	0.1	TO220-5, DDPak-5	\$6.85
OPA2544	2	20 to 70	1.4	8	15	5	10	0.1	ZIP11	\$12.00
THS3041	1.25	10 to 30	210	7300	10.5	3	10	20 $\mu$ A	SOIC, SOIC PowerPAD™	\$2.45
OPA547	0.5	8 to 60	1	6	15	5	25	500	TO220-7, DDPak-7	\$4.35
OPA548	3	8 to 60	1	10	20	10	30	500	TO220-7, DDPak-7	\$6.00
OPA549	8	8 to 60	0.9	9	35	5	20	500	ZIP11	\$12.00
OPA551	0.2	8 to 60	3	15	7	3	7	0.1	DIP8, SO8, DDPak-7	\$1.75
OPA552	0.2	8 to 60	12	24	7	3	7	0.1	DIP8, SO8, DDPak-7	\$1.75
OPA561	1.2	7 to 16	17	50	70	20	50	0.1	HTSSOP-20	\$2.65
<b>OPA567</b>	2.4	2.7 to 5.5	1.2	1.2	6	2	1.3	0.01	QFN-12 PowerPAD	\$1.85
<b>OPA569</b>	2.4	2.7 to 5.5	1.2	1.2	6	2	1.3	0.01	SO-20, PowerPAD	\$3.10

\*Suggested resale price in U.S. dollars in quantities of 1,000.

New products are listed in bold red.

### Buffers Selection Guide (Sorted by Ascending BW at A<sub>CL</sub>)

Device	V <sub>S</sub> $\pm 15$ (V)	V <sub>S</sub> $\pm 5$ (V)	V <sub>S</sub> 3.3 (V)	V <sub>S</sub> 5 (V)	A <sub>CL</sub> (min) Stable Gain (V/V)	BW at A <sub>CL</sub> (MHz)	Slew Rate (V/ $\mu$ s)	Settling Time 0.01% (ns) (typ)	I <sub>Q</sub> (mA) (typ)	THD (FC = 1MHz) (dB) (typ)	Diff Gain (%)	Diff Phase ( $^{\circ}$ )	V <sub>N</sub> at Flatband (nV/ $\sqrt$ Hz) (typ)	V <sub>OS</sub> (mV) (max)	I <sub>B</sub> ( $\mu$ A) (max)	Package(s)	Price*
OPA692	—	Yes	—	Yes	1	280	2000	12 [0.02%]	5.8	-78	0.07	0.02	1.7	2.5	45	SOT23, SOIC	\$1.45
OPA832	—	Yes	Yes	Yes	1	92	350	45 [0.1%]	5.9	-84	0.1	0.16	9.3	5	0.01	SOT23, SOIC	\$0.70
BUF634	Yes	Yes	—	Yes	1	180	2000	200	20	—	0.4	0.1	4	100	20	DIP, SOIC, TO220-5, DDPak-5	\$3.05
OPA633	Yes	Yes	—	—	1	260	2500	50	30	—	—	0.1	—	15	35	DIP	\$5.45
OPA693	No	Yes	No	Yes	1	1400	2500	12 (0.1%)	—	-84	0.03	0.01	1.8	2	45	SOT23, SOIC	\$1.30
<b>BUF602</b>	No	Yes	Yes	Yes	1	1200	8000	6 (0.05%)	5.8	—	0.15	0.04	4.8	16	7	SOT23, SOIC	\$0.85

\*Suggested resale price in U.S. dollars in quantities of 1,000.

New products are listed in bold red.

## Pulse Width Modulation Power Drivers



TI's pulse width modulation (PWM) power drivers are specifically designed for applications requiring high current at low to moderately high voltages, ranging from 5V to 60V. Loads include electromechanical loads, such as solenoids, coils, actuators, and relays, as well as heaters, lamps, thermoelectric coolers and laser diode pumps.

These products feature integrated power transistors, which save considerable circuit board area compared to discrete implementations. Unlike the operation of linear drivers, PWM operation offers efficiencies as great as 90%, resulting in less power wasted as heat and reduced demand on the power supply. The DRV10x operates from +8V to +60V and has a single low-side or high-side power switch. The devices in the DRV59x family may be analog or digitally controlled and operate from 0% to 100% duty cycles. The DRV59x operates on +2.8V to +5.5V and has internal H-bridge output switches in series with the load, allowing for bi-directional current flow from a single power supply.

### Design Considerations

**Supply voltage**—selection begins with the power supply voltages available in the system. TI's families of PWM power drivers operate from 2.8V to 5.5V for the DRV59x family and from 2.8 to 60V for the DRV10x family.

**Output current and output voltage**—the load to be connected to the power driver will also help determine the proper PWM power driver

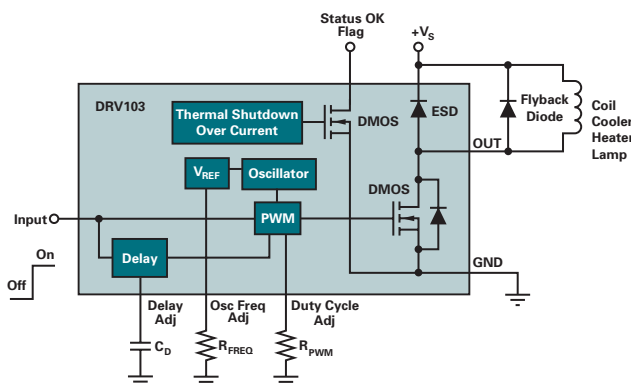

DRV103 low-side PWM driver block diagram.

solution. The maximum output current required by the load should be known. The maximum output voltage capability of the driver may be calculated as follows:

$$V_O (\text{max}) = V_S - [I_O (\text{max}) \cdot 2 \cdot R_{DS(ON)}]$$

**Efficiency**—a lower on-resistance ( $R_{ON}$ ) of the output power transistors will yield greater efficiency. Typically,  $R_{DS(ON)}$  is specified per transistor. In an H-bridge output configuration, two output transistors are in series with the load. To quickly estimate the efficiency, use the following equation:

$$\text{Efficiency} = R_L / [R_L + (2 \cdot R_{DS(ON)})]$$

**Analog or digital control**—TI offers both H-bridge and single-sided drivers. The DRV590, DRV591, DRV593 and DRV594 each accept a DC voltage input signal, either from an analog control loop (i.e., PID controller) or from a DAC, while the DRV592 accepts a PWM input signal.

**Output filter**—in some applications, a low-pass filter is placed between each output of the PWM driver and the load to remove the switching frequency components. A second-order filter consisting of an inductor and capacitor is commonly used, with the cut-off frequency of the filter typically chosen to be at least an order of magnitude lower than the switching frequency. For example, a DRV593 switching at 500kHz can have a 15.9kHz cut-off frequency. The component values are calculated using the following formula:

$$FC = 1 / [2 \cdot \pi \cdot (\sqrt{L \cdot C})]$$

The inductor value is typically chosen to be as large as possible, and is then used to calculate the required capacitor value for the desired cut-off frequency.

### PWM Power Drivers Selection Guide

Device	Description	Supply Voltage (V)	Output Current (A) typ	Saturation Voltage (V)	$R_{ON}$ ( $\Omega$ )	Frequency (kHz)	Package(s)	Price*
<b>Single Switch</b>								
DRV101	Low-Side with Internal Monitoring	9 to 60	2.3	1	0.8	25	T0-220, DDPAK	\$3.85
DRV102	High-Side with Internal Monitoring	8 to 60	2.7	2.2	0.95	25	T0-220, DDPAK	\$3.85
DRV103	Low-Side with Internal Monitoring	8 to 32	3	0.6	0.9	0.5 - 100 <sup>1</sup>	SO-8, SO-8 PowerPAD™	\$1.60
DRV104	High-Side with Internal Monitoring	8 to 32	2	0.65	0.45	0.5 - 100 <sup>1</sup>	HTSSOP-14 PowerPAD	\$1.60
<b>Bridge</b>								
DRV590	High-Efficiency PWM Power Driver	2.7 to 5.5	1.2	0.48	0.4	250/500	SO-PowerPAD, 4x4mm MicroStar Junior™	\$7.30
DRV591	±3A, High-Efficiency PWM Power Driver	2.8 to 5.5	3	0.195	0.065	100/500	9x9 PowerPAD QFP	\$6.30
DRV592	±3A, High-Efficiency H-Bridge	2.8 to 5.5	3	0.195	0.065	1000	9x9 PowerPAD QFP	\$12.50
DRV593	±3A, High-Efficiency H-Bridge	2.8 to 5.5	3	0.195	0.065	100/500	9x9 PowerPAD QFP	\$5.90
DRV594	±3A, High-Efficiency H-Bridge	2.8 to 5.5	3	0.195	0.065	100/500	9x9 PowerPAD QFP	\$5.90

<sup>1</sup>Adjustable internal oscillator frequency

\*Suggested resale price in U.S. dollars in quantities of 1,000.

## → Sensor Conditioners and 4-20mA Transmitters

The PGA309 is a complete voltage output bridge sensor conditioner that eliminates potentiometers and sensor trims. Span and Offset are digitally calibrated with temperature coefficients stored in a low-cost, SOT23-5, external EEPROM. Excitation voltage linearization, internal/external temperature monitoring and selection of internal/external voltage references including supply are provided. Over/Under scale limits are settable and fault detection circuitry is included.

The 4-20mA transmitter provides a versatile instrumentation amplifier (IA) input with a current-loop output, allowing analog signals to be sent over long distances without loss of accuracy. Many of these devices also include scaling, offsetting, sensor excitation and linearization circuitry. The XTR108 provides a digitally controlled analog signal path for RTD signal conditioning. The XTR108 allows for digital calibration of sensor and transmitter errors via a standard digital serial interface, eliminating expensive

potentiometers or circuit value changes. Calibration settings can be stored in an inexpensive external EEPROM for easy retrieval during routine operation.

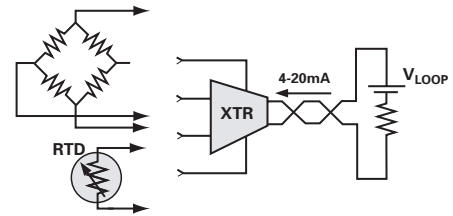

4-20mA transmitter design solutions.

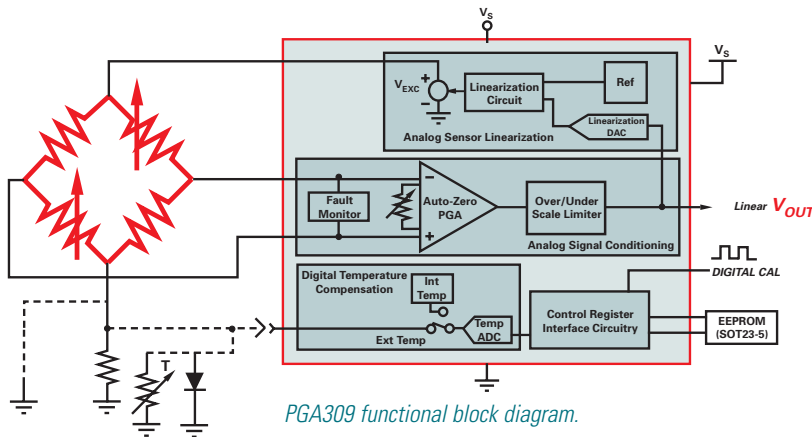

PGA309 functional block diagram.

### PGA309 Key Features

- Voltage output: ratiometric or absolute
- Digital calibration: no potentiometers, no sensor trim
- Sensor compensation: span and span drift, offset and offset drift
- <0.1% post-cal accuracy
- 2.7V to 5.5V operation
- Packaging: TSSOP-16

**See Page 33 for a Complete Listing of Digitally Programmable Gain Amplifiers**

## 4-20mA Transmitters and Receiver Selection Guide

Device	Description	Sensor Excitation	Loop Voltage (V)	Full-Scale Input Range	Output Range (mA)	Additional Power Available (V at mA)	Package(s)	Price*
<b>2-Wire 4-20mA Transmitters</b>								
XTR105	100Ω RTD Conditioner with Linearization	Two 800μA	7.5 to 36	5mV to 1V	4-20	5.1 at 1	DIP-14, SOIC-14	\$4.00
XTR106	Bridge Conditioner with Linearization	5V and 2.5V	7.5 to 36	5mV to 1V	4-20	5.1 at 1	DIP-14, SOIC-14	\$4.00
XTR108	10Ω to 10kΩ RTD Conditioner, 6-Channel Input Mux, Extra Op Amp Can Convert to Voltage Sensor Excitation, Calibration Stored in External EEPROM	Two 500μA	7.5 to 24	5mV to 320mV	4-20	5.1 at 2.1	SSOP-24	\$3.35
XTR112	1kΩ RTD Conditioner with Linearization	Two 250μA	7.5 to 36	5mV to 1V	4-20	5.1 at 1	DIP-14, SOIC-14	\$4.00
XTR114	10kΩ RTD Conditioner with Linearization	Two 100μA	7.5 to 36	5mV to 1V	4-20	5.1 at 1	DIP-14, SOIC-14	\$4.00
XTR115	I <sub>IN</sub> to I <sub>OUT</sub> Converter, External Resistor Scales V <sub>IN</sub> to I <sub>IN</sub>	V <sub>REF</sub> = 2.5V	7.5 to 36	40μA to 200μA	4-20	5.0 at 3.7	SOIC-8	\$1.05
XTR116	I <sub>IN</sub> to I <sub>OUT</sub> Converter, External Resistor Scales V <sub>IN</sub> to I <sub>IN</sub>	V <sub>REF</sub> = 4.096V	7.5 to 36	40μA to 200μA	4-20	5.0 at 3.7	SOIC-8	\$1.05
<b>Bridge Conditioner with Digital Calibration for Linearization, Span and Offset over Temperature</b>								
PGA309	Complete Digitally Calibrated Bridge Sensor Conditioner, Voltage Output, Calibration Stored in External EEPROM, One-Wire/Two-Wire Interface	V <sub>EXC</sub> = V <sub>S</sub> , 2.5V 4.096V	2.7 to 5.5	1mV/V to 245mV/V	0.1V to 4.9V at V <sub>S</sub> = +5V	—	TSSOP-16	\$3.40
<b>Industrial Current/Voltage Drivers</b>								
XTR110	0-20mA, 4-20mA Current Driver	V <sub>REF</sub> = 10V	13.5 to 40	0V to 5V, 0V to 10V	4-20, 0-20, 5-25	—	DIP-16	\$7.10
<b>XTR300</b>	Industrial Analog Current/Voltage Output Driver	—	<34	V <sub>CC</sub> +3 to V <sub>CC</sub> -3 Dig. selected V <sub>O</sub> ≤	±17V or I <sub>O</sub> ±24mA	—	5x5 QFN-20	\$2.45
<b>4-20mA Current Loop Receiver</b>								
RVC420	4-20mA Input, 0V to 5V Output, 1.5V Loop Drop	V <sub>REF</sub> = 10V	+11.5/-5 to ±18	4-20mA	0V to 5V	—	DIP-16	\$3.55

\*Suggested resale price in U.S. dollars in quantities of 1,000.

New products are listed in bold red.

## Sensor Conditioners and 4-20mA Transmitters



## Industrial Analog Voltage/ Current Driver XTR300

NEW

Get samples and datasheets at: [www.ti.com/sc/device/XTR300](http://www.ti.com/sc/device/XTR300)

The XTR300 is a complete output driver for industrial and process control applications. The output can be selected as current or voltage by the digital I/V select pin, error flags allow for convenient fault detection. Separate driver and receiver channels are provided for added flexibility. The integrated instrumentation amplifier (INA) can be used for remote voltage sensing or as a high-voltage, high-impedance measurement channel. For additional protection, maximum output current limit and thermal protection is provided.

### Key Features

- Pin select I or V output or input
- Pin select for output enable/disable (OE)
- Gain or transconductance set by external resistors
  - Output voltage swing:  $\pm 16$  at  $V_S = \pm 19V$
  - Output current:  $\pm 24mA$  (linear range)
- Packaging: 5mm x 5mm QFN-20

### Applications

- Analog interface between industrial high-voltage and low-voltage signal processing: PLC – I/O, Field Bus I/O

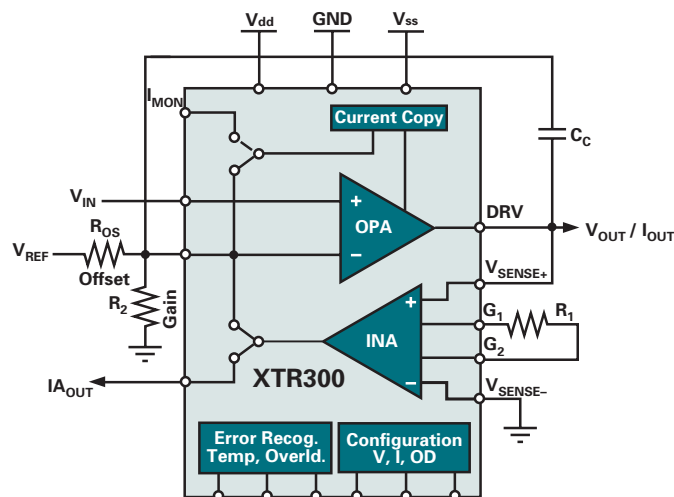

XTR300 functional block diagram.

## Programmable 4-20mA Transmitter with Programmable Signal Conditioning XTR108

Get samples, datasheets and app reports at:

[www.ti.com/sc/device/XTR108](http://www.ti.com/sc/device/XTR108)

The XTR108 is a new-generation programmable 4-20mA current loop transmitter. Its basic function is similar to TI's all-analog types, but the XTR108 has a digitally adjustable analog signal path that provides improved accuracy and lower cost. Digital calibration avoids potentiometers, component substitution and other expensive adjustment methods that are often difficult to calibrate manually. The XTR108 is designed for RTD temperature sensors, but it can be used with many other sensor types including metal and silicon pressure bridges. It incorporates an input and excitation multiplexer, auto-zeroed programmable-gain amplifier (PGA), current and voltage references, linearization circuitry and a voltage-to-current converter output stage.

### Key Features

- Complete 4-20mA transmitter function
- Voltage output pin for intermediate conditioning
- No potentiometers or manual trimming
- Serial SPI bus interface
- Uncommitted op amp for 4-wire RTD connections
- 5V sub-regulator for powering external circuitry
- Packaging: SSOP-24

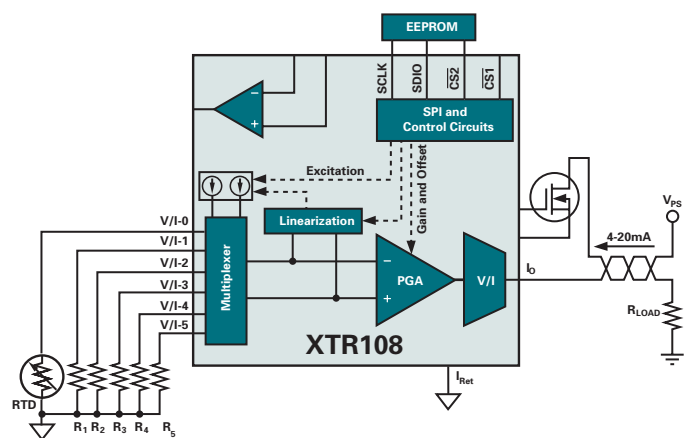

XTR108 functional block diagram.



## → Logarithmic Amplifiers

TI has achieved significant advancement in log amp technology. The logarithmic amplifier is a versatile integrated circuit that computes the logarithm of an input current relative to a reference current or the log of the ratio of two input currents. Logarithmic amplifiers can compress an extremely wide input dynamic range (up to 8 decades) into an easily measured output voltage. Accurate matched bipolar transistors provide excellent logarithmic conformity over a wide input current range. On-chip compensation achieves accurate scaling over a wide operating temperature range.

TI log amplifiers are designed for optical networking, photodiode signal compression, analog signal compression and logarithmic

computation for instrumentation. Some log amps, such as the LOG102, feature additional uncommitted op amps for use in a variety of functions including gain scaling, inverting, filtering, offsetting and level comparison to detect loss of signal. The LOG2112 is a dual version of the LOG112 and includes two log amps, two uncommitted output amps and a single shared internal voltage reference.

### Design Considerations

**Output scaling**—amplifier output is 0.32V, 0.5V or 1.0V per decade and is the equivalent of the gain setting in a voltage input amp.

**Quiescent current**—lowest in LOG101 and LOG104.

**Conformity error**—measured with 1nA to 1mA input current converted to 5V output. More than 16-bits of dynamic range are achievable.

**Auxiliary op amps**—some log amps have additional uncommitted op amps that can be used to offset and scale the output signal to suit application requirements.

### Technical Information

Log amplifiers provide a very wide dynamic range (up to 160dB), extremely good DC accuracy and excellent performance over the full temperature range.

### LOG112 Key Features

- Easy-to-use complete function
- Output scaling amplifier
- On-chip 2.5V voltage reference
- High accuracy: 0.2% FSO over 5 decades
- Wide input dynamic range: 7.5 decades, 100pA to 3.5mA
- Low quiescent current: 1.75mA
- Wide supply range: ±4.5V to ±18V
- Packaging: SO-14 (narrow) and SO-16

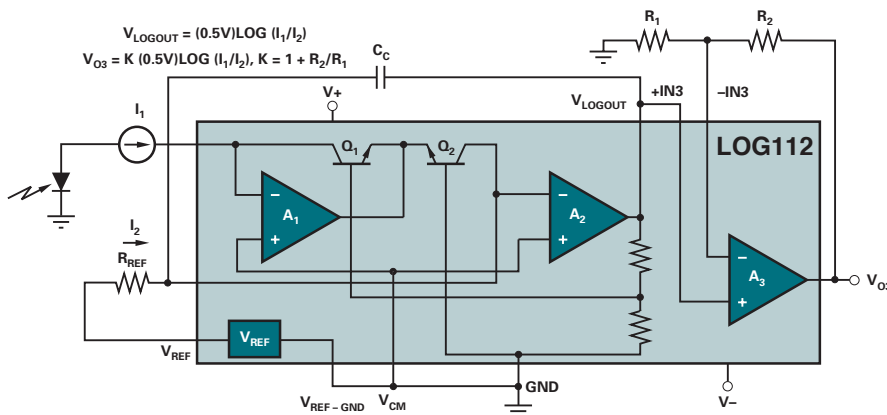

NOTE: Internal resistors are used to compensate gain change over temperature. The  $V_{CM}$  pin is internally connected to GND in the LOG2112.

LOG112 functional block diagram.

## Logarithmic Amplifiers Selection Guide

Device	Scale Factor (V/Decade)	Input Current Range (nA) (min) (max)	Input Current Range (mA) (min) (max)	Conformity Error (Initial 5 Decades) (%) (max)	Conformity Error (Initial 5 Decades) (%/°C) (typ/temp)	Offset Voltage Input Amplifiers (mV) (max)	$V_S$ (V) (min)	$V_S$ (V) (max)	$I_Q$ Per Ch. (mA) (max)	Reference Type	Auxiliary Op Amps	Package(s)	Price*
LOG101	1	0.1	3.5	0.2	0.0001	1.5	±4.5	±18	1.5	External	—	SO-8	\$6.95
LOG102	1	1	1	0.3	0.0002	1.5	±4.5	±18	2	External	2	SO-14	\$7.25
LOG104	0.5	0.1	3.5	0.2	0.0001	1.5	±4.5	±18	1.5	External	—	SO-8	\$6.95
LOG112	0.5	0.1	3.5	0.2	0.00001	1.5	±4.5	±18	1.75	2.5V Internal	1	SO-14	\$7.90
LOG2112	0.5	0.1	3.5	0.2	0.00001	1.5	±4.5	±18	1.75	2.5V Internal	1/Ch.	SO-16	\$11.35
LOG114	0.32	0.01V	1V	—	—	—	±6	±8	5.75	—	—	DIP/SOP-16	\$3.24
TL441 <sup>1</sup>	0.32	0.01V	1V	—	—	—	±6	±8	5.75	—	—	DIP/SOP-16	\$3.24

<sup>1</sup>80dB, 40MHz log amplifier  $I_F$  video applications. \*Suggested resale price in U.S. dollars in quantities of 1,000.

## Integrating Amplifiers



Integrating amplifiers provide a precision, lower noise alternative to conventional transimpedance op amp circuits which require a very high value feedback resistor. Designed to measure input currents over an extremely wide dynamic range, integrating amplifiers incorporate a FET op amp, integrating capacitors, and low-leakage FET switches. Integrating low-level input current for a user-defined period, the resulting voltage is stored on the integrating capacitor, held for accurate measurement and then reset. Input leakage of the IVC102 is only 750fA. It can also measure bipolar input currents.

The ACF2101 two-channel integrator offers extremely low bias current, low noise, an extremely wide dynamic range and excellent channel isolation. Included on each of the two integrators are precision 100pF integration capacitors, hold and reset switches and output multiplexers. As a complete circuit on a chip, leakage current and noise pickup errors are eliminated. An output capacitor can be used in addition to (or instead of) the internal capacitor depending on design requirements.

### Design Considerations

**Supply voltage**—while single-supply operation is feasible, bipolar-supply operation is most common and will offer the best performance in terms of precision and dynamic range.

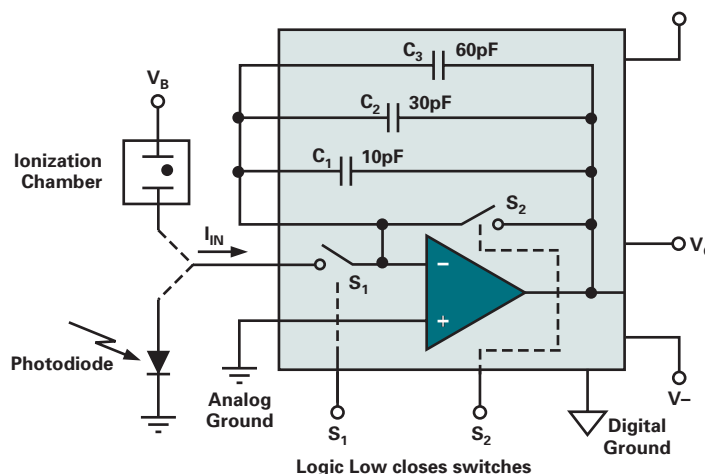

IVC102 functional block diagram.

**Number of channels**—IVC102 offers a single integrator, while the ACF2101 is a dual.

**Integration direction**—either into or out of the device. IVC102 is a bipolar input current integrator and will integrate both positive and negative signals. ACF2101 is a unipolar current integrator, with the output voltage integrating negatively.

**Input bias (leakage) current**—often sets a lower limit to the minimum detectable signal input current. Leakage can be subtracted from measurements to achieve extremely low-level current detection (<10fA). Circuit board leakage currents can also degrade the minimum detectable signal.

**Sampling rate and dynamic range**—the switched integrator is a sampled system controlled by the sampling frequency (fs),

which is usually dominated by the integration time. Input signals above the Nyquist frequency (fs/2) create errors by being aliased into the sampling frequency bandwidth.

### Technical Information

Although these devices use relatively slow op amps, they may be used to measure very fast current pulses. Photodiode or sensor capacitance can store a pulse charge temporarily, the charge is then slowly integrated during the next cycle.

See the OPT101 data sheet for monolithic photodiode and transimpedance amplifier. The OPT101 converts light directly into a voltage output, with low leakage current errors, minimal noise pick-up and low gain peaking due to stray capacitance.

## Integrating Amplifiers Selection Guide

Device	Description	Input	Noise at	Switching	Useful	Input	Power	I <sub>Q</sub>	Package(s)	Price*
		Bias Current (fA) (max)	1kHz (nV/√Hz) (typ)	Time (μs) (typ)	Sampling Rate (kHz)	Current Range (μA)	Supply (V)	(mA) (max)		
IVC102	Precision, Low Noise, Bipolar Input Current	±750	10	100	10	0.01 to 100	+4.75 to +18 -10 to -18	5.5 -2.2	S0-14	\$4.55
ACF2101	Dual, Unipolar	1000	—	200	10	0.01 to 100	+4.75 to +18 -10 to -18	15 5.2	S0-24	\$15.55
Monolithic Photodiode and Transimpedance Amplifier										
OPT101	Monolithic Photodiode with Built-In Transimpedance Amplifier	165	—	—	14	—	+2.7 to +36	0.24	PDIP-8, SOP-8	\$2.75

\*Suggested resale price in U.S. dollars in quantities of 1,000.

## → Isolation Amplifiers

There are many applications where it is desirable, even essential, that a sensor not have a direct (galvanic) electrical connection with the system to which it is supplying data in order to avoid either dangerous voltages or currents from one half of the system from damaging the other half. Such a system is said to be "isolated", and the area which passes a signal without galvanic connections is known as an "isolation barrier".

Isolation barrier protection works in both directions, and may be needed in either half of the system, sometimes both. Common applications requiring isolation protection are

those where sensors may accidentally encounter high voltages and the system it is driving must be protected. Or a sensor may need to be isolated from accidental high voltages arising downstream in order to protect its environment: examples include prevention of explosive gas ignition caused by sparks at sensor locations or protecting patients from electric shock by ECG, EEG and EMG test and monitoring equipment. The ECG application may require isolation barriers in both directions: the patient must be protected from the very high voltages (>7.5kV) applied by the defibrillator, and the

technician handling the device must be protected from unexpected feedback.

### Applications for Isolation Amplifiers

- Sensor is at a high potential relative to other circuitry (or may become so under fault conditions)
- Sensor may not carry dangerous voltages, irrespective of faults in other circuitry (e.g. patient monitoring and intrinsically safe equipment for use with explosive gases)
- To break ground loops

### 3.3V, High-Speed Digital Isolators ISO721, ISO722

NEW

Get samples, datasheets, EVMs and app reports at: [www.ti.com/sc/device/ISO721](http://www.ti.com/sc/device/ISO721)

#### Key Features

- 4000V isolation
- Fail-safe output
- Signaling rate up to 100Mbps
- UL 1577, IEC 60747-5-2 (VDE 0884, Rev. 2), IEC 61010-1 and CSA Approved
- 25kV/ $\mu$ s transient immunity

#### Applications

- Industrial fieldbus
- Servo monitoring and control

The ISO721 digital isolator is a logic input and output buffer separated by a silicon oxide (SiO<sub>2</sub>) insulation barrier that provides galvanic isolation of up to 4000V. Used in conjunction with isolated power supplies, the device prevents noise currents on a data bus or other circuits from entering the local ground and interfering with or damaging sensitive circuitry.

A binary input signal is conditioned, translated to a balanced signal, then differentiated by the capacitive isolation barrier. Across the isolation barrier, a differential comparator receives the logic transition information, then sets or resets a flip-flop and the output circuit accordingly. A periodic update pulse is sent across the barrier to ensure the proper dc level of the output. If this dc-refresh pulse is not received for more than 4 $\mu$ s, the input is assumed to be unpowered or not functional and the fail-safe circuit drives the output to a logic high state.

ISO721 functional block diagram.

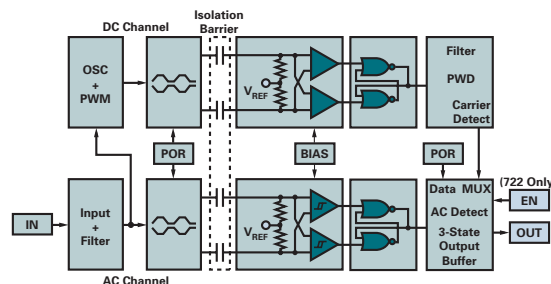

### Isolation Amplifiers Selection Guide

Device	Description	Isolation Voltage Cont Peak (DC) (V)	Isolation Voltage Pulse/Test Peak (V)	Isolation Mode Rejection DC (dB) (typ)	Gain Nonlinearity (%) (max)	Input Offset Voltage Drift ( $\pm\mu$ V/ $^{\circ}$ C) (max)	Small-Signal Bandwidth (kHz) (typ)	Package(s)	Price*
ISO122	1500V <sub>RMS</sub> Isolation, Buffer	2121	2400	140	0.02	200	50	DIP-16, SOIC-28	\$9.40
ISO124	1500V <sub>RMS</sub> Isolation, Buffer	2121	2400	140	0.01	200	50	DIP-16, SOIC-28	\$7.20

#### Digital Couplers

Device	Description	Isolation Voltage Cont Peak (DC) (V)	Isolation Voltage Pulse/Test Peak (V)	Peak Transient Overvoltage VIOTM (V)	Working Voltage VIORM (V)	Data Rate (max) (Mbps)	Transient Immunity (min) (KV/ $\mu$ s)	Propagation Delay at 5V (max) (ns)	PWD at 5V (max) (ns)	ICCC at 5V (max) (mA)	Supply Voltage	Package(s)	Price*
ISO150	Dual Channel Bi-directional Digital Isolator	1500	2400	—	—	80	1.6	40	6	10	5V	DIP-12, SO-12	\$8.10
<b>ISO721</b>	Single Channel, 3.3V/5V Digital Isolators	—	—	4000	560	100	25	24	2	13	3.3V, 5V	SO-8	\$1.65
<b>ISO721M</b>	Single Channel, 3.3V/5V Digital Isolators	—	—	4000	560	150	25	16	1	13	3.3V, 5V	SO-8	\$1.65

\*Suggested resale price in U.S. dollars in quantities of 1,000.

New products are listed in bold red.

## Amplifiers for Driving Analog-to-Digital Converters



Data acquisition systems generally require an amplifier preceding the ADC to buffer the input signal. Most modern ADCs possess complex input characteristics due to the capacitive charging and switching that occurs during sampling and conversion. This behavior causes transient currents on the ADC's input that can disturb or distort a precision analog input signal. The input amplifier serves to provide a stable, accurate signal in the presence of these current transients. It can also provide gain (or attenuation), level shifting, filtering and other signal conditioning functions.

Selecting the input op amp requires attention to many considerations. DC accuracy may narrow the possible choices of an amplifier. The amplifier must have sufficiently low offset voltage, offset voltage drift, input bias current, noise, and so forth, to meet the required accuracy performance. It is often the dynamic performance characteristics, however, that prove most troublesome in the selection process. The amplifier must preserve the required dynamic signal characteristics.

### Design Considerations

**Time domain issues**—some applications demand that the amplifier respond accurately to full-scale changes in input voltage. For example, a multiplexed-input system may have input voltages equal to full-scale extremes on two adjacent inputs. The amplifier and ADC must respond to this sudden full-scale change in one sampling period.

**Settling time**—an all-encompassing specification used to describe the ability of an amplifier to respond to a large change in

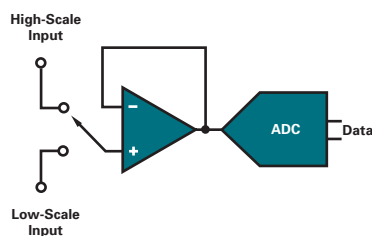

*Multiplexed data acquisition systems require excellent dynamic behavior from op amps.*

input voltage. The settling time includes the large-signal period determined by slew rate and the small-signal settling period determined primarily by the bandwidth of the amplifier. Slewing time varies with the step size. Though generally specified for a specific step size, the settling time for other step sizes can be inferred from the slewing portion of the step.

The small-signal portion of the settling waveform is affected by the gain of the input amplifier. If the amplifier is placed in a higher gain, system bandwidth is reduced, proportionally increasing the small-signal portion of the settling waveform.

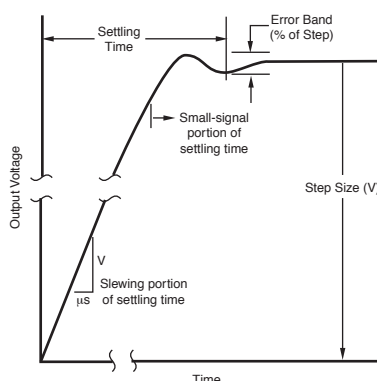

**Frequency domain performance**—many ADCs are used to digitize dynamic waveforms such as audio. Rapid full-scale signal steps are rarely, if ever, encountered in these systems. For this reason, such systems generally specify spectral purity of the digitized signal. The amplifier must support this application with the required distortion performance. Many amplifiers specify THD+N (total harmonic distortion + noise). Other measures are also used. All these measures are made by applying a pure sine wave (or combination of sine waves) and measuring the spectral content in the amplifier's output that are not present in its input signal.

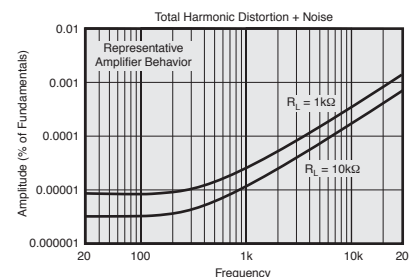

### Technical Information

The input amplifier is generally connected to the ADC through an R-C network. Though often called a filter, this network actually serves as a "flywheel" in the presence of the current pulses created by the ADC's input circuitry. The circuit values of this circuit depend on both the amplifier and the ADC characteristics and often must be optimized for a particular application. The optimum capacitor value is generally in the range of 10 to 50 times the input capacitance of the ADC. The resistor is chosen to meet the speed or bandwidth requirement of the application.

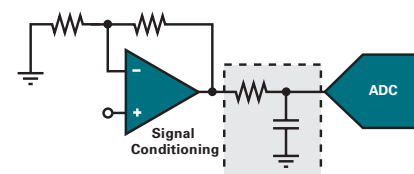

*"Flywheel" conditioning network.*

The op amps shown in the following table are among the most likely choices for the indicated conversion speeds and ADC architectures. Depending on specific application requirements, other amplifiers may provide improved performance.

For a complete list of op amps, visit: [amplifier.ti.com](http://amplifier.ti.com)

## → Amplifiers for Driving Analog-to-Digital Converters

### Amplifiers for ADCs Selection Guide

Device	Description	Ch.	V <sub>S</sub> (V) (min)	V <sub>S</sub> (V) (max)	I <sub>O</sub> Per Ch. (mA) (max)	GBW (MHz) (typ)	Stew Rate (V/μs) (typ)	V <sub>OS</sub> (25°C) (mV) (max)	Offset Drift (μV/°C) (typ)	I <sub>B</sub> (pA) (max)	V <sub>N</sub> at 1kHz (nV/√Hz) (typ)	Single Supply	Rail- to- Rail	Package(s)	Price*
<b>For Use with Medium-Speed SAR ADCs (&lt;250kSPS)</b>															
INA155	Medium Speed, Precision INA	1	2.7	5.5	2.1	0.55	6.5	1	5	10	40	Y	Out	MSOP	\$1.10
INA128	High Precision, 120dB CMRR	1	4.5	36	0.75	1.3	4	0.5	0.2	5000	8	N	N	PDIP, SOIC	\$3.05
INA331	High Bandwidth, Single Supply	1, 2	2.7	5.5	0.5	5	5	0.5	5	10	46	Y	Out	MSOP	\$1.10
OPA340	CMOS, 0.0007% THD+N	1, 2, 4	2.7	5.5	0.95	5.5	6	0.5	2.5	10	25	Y	I/O	SOT-23, MSOP	\$0.80
OPA363	1.8V, High CMRR, SHDN	1, 2	1.8	5.5	0.75	7	5	0.5	2	10	17	Y	I/O	SOT-23, MSOP	\$0.60
<b>OPA2613</b>	Dual VFB, Low Noise	2	5	12.6	6	12.5	70	1	3.3	12μA	1.8	Y	N	SOIC, SOIC PowerPAD™	\$1.55
TLE2027	Precision, Low Noise	1	8	38	5.3	13	2.8	0.1	0.4	90000	2.5	N	N	SOIC	\$0.90
OPA627	Ultra-Low THD+N, Wide BW	1	9	36	7.5	16	55	0.1	0.4	5	5.2	N	N	PDIP, SOIC	\$12.25
OPA381	Precision High Speed Amp	1, 2	2.7	5.5	1	18	12	0.025	0.03	50	10	Y	Out	DFN, MSOP	\$1.45
OPA228	Precision, Low Noise, G ≥ 5	1, 2, 4	5	36	3.8	33	10	0.075	0.1	10000	3	N	N	PDIP, SOIC	\$1.10
OPA350	Precision ADC Driver	1, 2, 4	2.7	5.5	7.5	38	22	0.5	4	10	5	Y	I/O	PDIP, MSOP	\$1.30
<b>THS4281</b>	Very Low Power RRIO	1	2.7	15	1	80	35	3.5	4	10	12.5	Y	I/O	SOT-23, MSOP, SOIC	\$0.95
THS4032	100MHz, Low Noise	2	5	30	8.5	230	100	2	10	6	1.6	N	N	MSOP PowerPAD™, SOIC	\$3.35
OPA820	Wideband, Low Noise, VFB	1	5	12.6	5.8	280	240	0.75	4	9μA	2.5	Y	N	SOIC, SOT-23	\$0.90
<b>For Use with High-Resolution, Delta-Sigma (ΔΣ) ADCs</b>															
OPA335	5V, Precision, Auto-Zero Amp	1, 2	2.7	5.5	0.35	2	1.6	0.005	0.02	200	5.8	Y	Out	SOT-23, MSOP	\$1.00
OPA735	12V, Precision, Auto-Zero Amp	1	2.7	13.2	0.75	1.6	1.5	0.005	0.05	200	—	Y	Out	SOT-23, MSOP	\$1.25
OPA277	Low Offset and Drift	1, 2, 4	4	36	0.825	1	0.8	0.02	0.1	1000	8	N	N	QFN, SOIC, PDIP	\$0.85
OPA227	Ultra-Low Noise, Bipolar Input	1, 2, 4	5	36	3.8	8	2.3	0.075	0.1	10000	3	N	N	QFN, PDIP, SOIC	\$1.10
INA326	Auto-Zero INA, 110dB CMRR	1	2.5	5.5	3.4	1kHz	—	0.1	0.4	2000	33	Y	I/O	MSOP	\$1.80
OPA627	Ultra-Low THD+N, Difet™	1	9	36	7.5	16	55	0.1	0.4	5	5.2	N	N	PDIP, SOIC	\$12.25
OPA336	High Precision, μPower Amp	1, 2, 4	2.3	5.5	0.032	0.1	0.03	0.125	1.5	10	40	Y	Out	MSOP, PDIP	\$0.40
<b>INA159</b>	Level Translation Amp	1	1.8	5.5	1.4	1.5	15	0.5	2	—	30	Y	I/O	MSOP	\$1.50
INA152	Single-Supply Difference Amp	1	2.7	20	0.65	0.8	0.4	1.5	3	—	87	Y	Out	MSOP	\$1.20
<b>For Use with High-Speed SAR (&gt;250kSPS) ADCs</b>															
<b>OPA2613</b>	Dual VFB, Low Noise	2	5	12.6	6	12.5	70	1	3.3	12μA	1.8	Y	N	SOIC, SOIC PowerPAD	\$1.55
OPA727	CMOS, e-trim™, Low Noise	1, 2, 4	4	12	6.5	20	30	0.15	1.5	100	11	Y	N	MSOP, DFN, TSSOP	\$1.45
<b>OPAy365</b>	High-Speed, Zero-Crossover™, CMOS	1, 2	2.2	5.5	5	50	25	0.5	1	10	100	5	IN	SOT23, SO-8	\$0.95
<b>OPA358</b>	CMOS, 3V Operation, SC70	1	2.7	3.3	7.5	80	55	6	5	50	6.4	Y	Y	SC70	\$0.45
OPA2830	Dual, Low Power, Wideband, SS	2	3	11	3.9	100	500	1.5	27	10	9.5	Y	Out	MSOP, SOIC	\$1.20
THS4130/31	Differential In/Out, SHDN	1	5	30	15	135	52	2	4.5	6μA	1.3	Y	N	SOIC, MSOP	\$2.75
OPA300	5V, SS, 16-Bit Settling Time	1	2.7	5.5	10	180	80	5	4	2	3	Y	Out	SOT-23	\$1.25
OPA355	CMOS, 2.7V Operation, SOT23	1, 2, 3	2.7	5.5	11	200	300	9	7	50	5.8	Y	Out	SOT-23, SOIC	\$0.90
OPA842	Low Distortion, VFB	1	8	12.6	20.2	200	400	1.2	4	35	2.6	N	N	SOT-23, SOIC	\$1.55
THS4032	100MHz, Low noise	2	5	30	8.5	230	100	2	10	6	1.6	N	N	MSOP PowerPAD™, SOIC	\$3.35
OPA2822	Dual Wideband, Low Noise, VFB	2	4	12.6	4.8	240	170	1.2	5	12μA	2	Y	N	SOIC, MSOP	\$1.45
OPA820	Wideband, Low Noise, VFB	1	5	12.6	5.75	280	240	0.75	4	17μA	2.5	Y	N	SOT-23, SOIC	\$0.90
<b>For Use with High-Speed Data Converters (Pipeline and Flash ADCs)</b>															
<b>OPA2613</b>	Dual VFB, Low Noise	2	5	12.6	6	12.5	70	1	3.3	12μA	1.8	Y	N	SOIC, SOIC PowerPAD	\$1.55
OPA842	Low Distortion, VFB	1	7	12.6	20.2	200	400	1.2	4	35μA	2.6	Y	N	SOT-23, SOIC	\$1.55
OPA847	Low Noise, VFB with SHDN	1	7	12.6	18.1	3900	950	0.5	0.25	39μA	0.85	Y	N	SOT-23, SOIC	\$2.00
OPA843	Low Distortion, G ≥ +3, VFB	1	7	12.6	20.2	800	1000	1.2	4	35μA	2	Y	N	SOT-23, SOIC	\$1.60
OPA698	Wideband, VFB w/Limiting	1	5	12.6	15.5	250	1100	5	15	10μA	5.6	Y	N	SOIC	\$1.90
OPA2690	Dual VFB w/Disable Limiting	2	5	12.6	5.5	300	1800	4.5	12	10μA	5.5	Y	N	SOIC	\$2.15
THS4502/03	Differential In/Out, SHDN	1	4.5	15	28	370	2800	-4/+2	10	4.6μA	6.8	Y	N	MSOP	\$4.00
OPA695	Ultra-Wideband CFB	1	5	12.6	12.3	—	4300	3	10	37μA	1.8	Y	N	SOT-23, SOIC	\$1.35
<b>THS4511</b>	Wideband, Low Noise, FDA <sup>1</sup>	1	3	5	39.2	2000	4900	5.2	2.6	15.5μA	2	Y	N	QFN	\$3.45
<b>THS4513</b>	Wideband, Low Noise, FDA <sup>1</sup>	1	3	5	37.7	2000	5100	5.2	2.6	13μA	2.2	Y	N	QFN	\$3.25
<b>THS4508</b>	Wideband, FDA <sup>1</sup>	1	3	5	39.2	3000	6400	5	2.6	15.5μA	2.3	Y	N	QFN	\$3.95
THS4509	Low Distortion, FDA <sup>1</sup>	1	3	5	37.7	3000	6600	0.8	2.6	13μA	1.9	Y	N	QFN	\$3.75
<b>THS4520</b>	Rail-to-Rail Output, FDA <sup>1</sup>	1	3	5	14	1400	570	—	—	—	1.6	Y	Out	QFN	\$2.45

<sup>1</sup>Fully differential amplifier \* Suggested resale price in U.S. dollars in quantities of 1,000.

New products are listed in bold red. Preview products are listed in bold blue.



## Delta-Sigma ( $\Delta\Sigma$ ) ADCs



Delta-sigma converters are capable of very high resolution, and are ideal for converting signals over a very wide range of frequencies from DC to several megahertz. In a delta-sigma ADC, the input signal is oversampled by a modulator, then filtered and decimated by a digital filter producing a high-resolution data stream at a lower sampling rate.

The delta-sigma architecture approach allows resolution to be traded for speed and both to be traded for power. This nearly continuous relationship between data rate, resolution and power consumption makes delta-sigma converters extraordinarily flexible. In many delta-sigma converters, this relationship is programmable, allowing a single device to handle multiple measurement requirements.

Because delta-sigma converters oversample their inputs, they can perform most anti-aliasing filtering in the digital domain. Modern VLSI design techniques have brought the cost of complex digital filters far below the cost of their analog equivalents. Formerly unusual functions, such as simultaneous 50Hz and 60Hz notch filtering, are now built into many delta-sigma ADCs.

Typical high-resolution applications for delta-sigma ADCs include audio, industrial process control, analytical and test instrumentation and medical instrumentation.

Recent innovations in ADC architectures have led to a new class of ADC architecture which uses both the pipeline and the oversampling principle. These, very high speed converters push the data rates into the MSPS range, while maintaining resolutions of 16-bits and higher. These speeds enable a host of new wide bandwidth signal processing applications such as communications and medical imaging.

Most delta-sigma ADCs have inherently differential inputs. They measure the actual difference between two voltages, instead of the difference between one voltage and ground. The differential input structure of a delta-sigma makes it ideal for measuring

differential sources such as bridge sensors and thermocouples. Frequently, no input amplifiers are required for these applications.

Delta-sigma converters work differently than SAR converters. A SAR takes a "snapshot" of an input voltage and analyzes it to determine the corresponding digital code. A delta-sigma measures the input signal for a certain period of time and outputs a digital code corresponding to the signal's average over that time. It is important to remember the way delta-sigma converters operate, particularly for designs incorporating multiplexing and synchronization.

It is very easy to synchronize delta-sigma converters together, so that they sample at the same time but it's more difficult to synchronize a delta-sigma converter to an external event. Delta-sigma converters are highly resistant to system clock jitter. The action of oversampling effectively averages the jitter, reducing its impact on noise.

Many delta-sigma converters include input buffers and programmable gain amplifiers (PGA). An input buffer increases the input impedance to allow direct connection to high source impedance signals. A PGA increases the converter's resolution when measuring small signals. Bridge sensors are an example of a signal source that can take advantage of the PGA within the converter.

Every ADC requires a reference, and for high-resolution converters, low-noise, low-drift references are critical. Most delta-sigma converters have differential reference inputs.

The following pages provide a broad range of delta-sigma ADCs available from Texas Instruments for a wide range of applications.

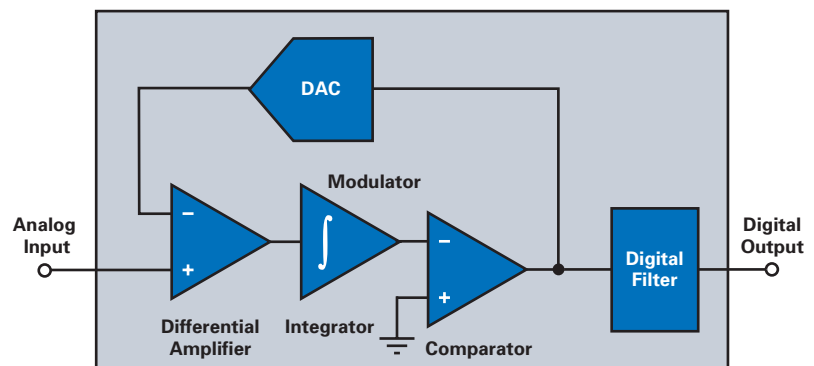

*Delta-sigma ADCs consist of a delta-sigma modulator followed by a digital decimation filter. The modulator incorporates a comparator and integrator in a feedback loop with a DAC. The loop is synchronized by a clock.*

## → Delta-Sigma ( $\Delta\Sigma$ ) ADCs

### Complete Analog Front End for Bridge Sensors

#### ADS1232, ADS1234

NEW

Get samples, datasheets and EVMs at: [www.ti.com/sc/device/ADS1232](http://www.ti.com/sc/device/ADS1232) and [www.ti.com/sc/device/ADS1234](http://www.ti.com/sc/device/ADS1234)

#### Key Features

- Very low noise:
  - 17nV<sub>RMS</sub> at 10SPS (PGA = 128)
  - 44nV<sub>RMS</sub> at 80SPS (PGA = 128)
- 19.2-bit noise-free resolution at Gain = 64
- Excellent 50 to 60MHz rejection (at 10SPS)
- 2-channel differential input: ADS1232
- 4-channel differential input: ADS1234
- Built-in temperature sensor
- Simple 2-wire serial digital interface
- Supply range: 2.7V to 5.3V
- Packaging: TSSOP-24 (ADS1232); TSSOP-28 (ADS1234)

#### Applications

- Weigh scales
- Strain gauges
- Pressure sensors
- Industrial process control

The ADS1232 and ADS1234 are precision 24-bit, delta-sigma ADCs with an onboard very low noise programmable gain amplifier and internal oscillator. The PGA supports user-selectable gains of 1, 2, 64 and 128. The ADC features 23.5-bits effective resolution, is comprised of a 3rd-order modulator and 4th-order digital filter and supports 10SPS and 80SPS data rates. All functions are controlled by dedicated I/O pins for easy operation.

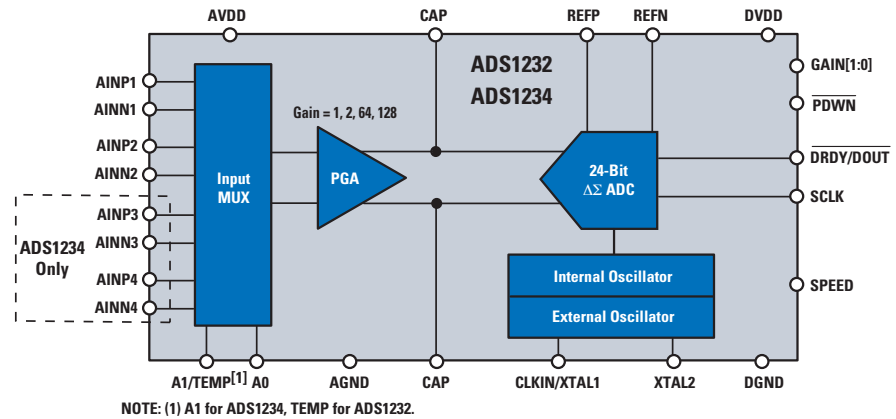

ADS1232 functional block diagram.

### 16-Channel, Fast Cycling, 24-Bit, Low-Noise ADC

#### ADS1258

NEW

Get samples, datasheets and EVMs at: [www.ti.com/sc/device/ADS1258](http://www.ti.com/sc/device/ADS1258)

#### Key Features

- 24-bits, no missing codes
- Fixed-channel or automatic-channel scan
- Data rate: 125kSPS fixed-channel; 23.7kSPS auto-scan of 16-channels
- Low noise: 2.8 $\mu$ V<sub>RMS</sub> at 1.8kSPS
- Integral nonlinearity: 0.0003%
- Offset drift: 0.02 $\mu$ V/°C
- Gain drift: 0.4ppm/°C
- Power dissipation: 42mW
- Standby, sleep and power-down modes
- Supply range: +5V (unipolar);  $\pm$ 2.5V (bipolar)
- Packaging: QFN-48

#### Applications

- Medical, avionics and process control
- Machine and system monitoring
- Fast scan multi-channel instrumentation
- Industrial systems
- Test and measurement systems

The ADS1258 is a 16-channel (multiplexed), delta-sigma ADC that provides single-cycle settled data at a channel scan rate from 1.8kSPS to 23.7kSPS. A flexible input multiplexer accepts combinations of eight differential or 16 single-ended inputs with a full-scale differential range of 5V, or true bipolar range of  $\pm$ 2.5V, when operating with a 5V reference. Internal system monitor registers provide supply voltage, temperature, reference voltage, gain and offset data.

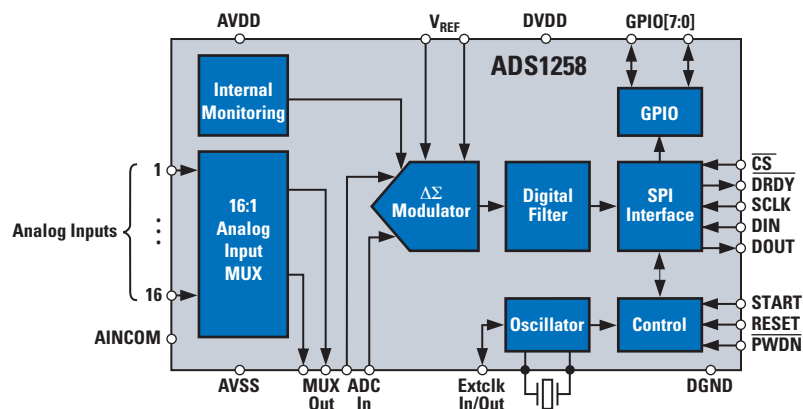

ADS1258 functional block diagram.



NEW

**16-Bit, 10MSPS, Very Wide Bandwidth ADC**  
**ADS1610**

Get samples, datasheets, EVMs and app reports at: [www.ti.com/sc/device/ADS1610](http://www.ti.com/sc/device/ADS1610)

**Key Features**

- Output data rate: 10MSPS
- Signal bandwidth: 4.9MHz
- SNR: 86dBFS
- THD: -94dB
- SFDR: 95dB
- SYNC pin for simultaneous sampling with multiple ADS1610s
- Group delay: 3µs
- Pin-compatible with ADS1605 (5MSPS ADC)
- Packaging: TQFP-64

**Applications**

- Scientific instruments
- Test equipment
- Communications
- Wide-band signal analysis

The ADS1610 is a 10MSPS, high-precision  $\Delta\Sigma$  ADC operating from a +5V analog and a +3V digital supply. Featuring an advanced multi-stage analog modulator combined with on-chip digital decimation filter, the ADS1610 achieves 86dBFS SNR at a 4.9MHz signal bandwidth. Output data is supplied over a parallel interface and easily connects to TMS320™ digital signal processors (DSPs). Power dissipation can be adjusted with an external resistor, allowing for reduction at lower operating speeds.

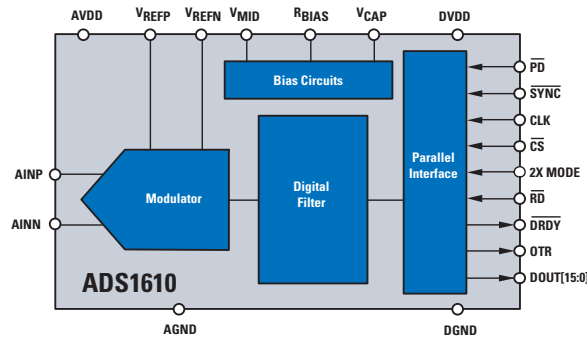

ADS1610 functional block diagram.

**24-Bit ADC with DC Accuracy and AC Performance**  
**ADS1271**

NEW

Get samples, datasheets, EVMs and app reports at: [www.ti.com/ADS1271](http://www.ti.com/ADS1271)

**Key Features**

- AC performance:
  - Bandwidth: 51kHz
  - THD: -105dB
- DC accuracy:
  - Offset drift: 1.8µV/°C
  - Gain drift: 2ppm/°C
- Selectable operating modes:
  - High speed: 105kSPS data rate
  - High resolution: 109dB SNR
  - Low power: 35mW dissipation
- Selectable SPI or Frame Sync Serial interface
- Designed for multichannel systems:
  - Daisy-chainable serial interface
  - Easy synchronization
- Analog supply: 5V
- Digital supply: 1.8V to 3.3V

The ADS1271 is a 24-bit, delta-sigma ADC with a data rate up to 105kSPS. It offers the unique combination of excellent DC accuracy and outstanding AC performance. The high-order, chopper-stabilized modulator achieves very low drift with low in-band noise. The onboard decimation filter suppresses modulator and out-of-band noise.

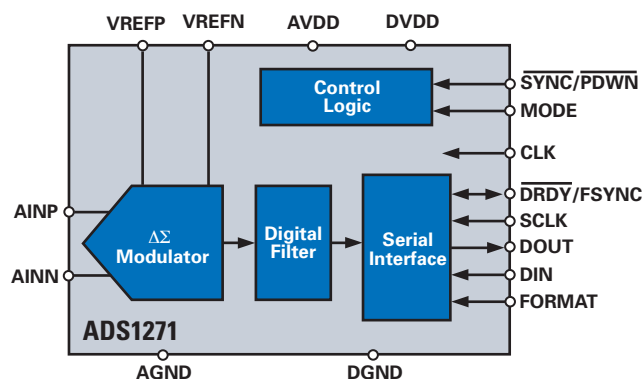

ADS1271 functional block diagram.

*Traditionally, industrial delta-sigma ADCs offering good drift performance used digital filters with large passband droop. As a result, they have limited signal bandwidth and are mostly suited for DC measurements. High-resolution ADCs in audio applications offer larger usable bandwidths, but the offset and drift specification are significantly weaker than their industrial counterparts. The ADS1271 combines these converter types, allowing high-precision industrial measurement with excellent DC and AC specifications ensured over an extended industrial temperature range.*

**Applications**

- Vibration/modal analysis
- Acoustics
- Dynamic strain gauges
- Pressure sensors
- Test and measurement

**Delta-Sigma ( $\Delta\Sigma$ ) ADCs****Delta-Sigma ( $\Delta\Sigma$ ) ADCs Selection Guide**

Device	Res. (Bits)	Sample Rate (kSPS)	Number of Input Channels	Interface	Input Voltage (V)	V <sub>REF</sub>	Linearity (%)	Power (mW)	Package(s)	Price*
<b>ADS1258</b>	24	125	16 SE/8 Diff	Serial, SPI	5, $\pm 2.5$	Ext	0.0015	40	QFN-48	\$7.95
<b>ADS1274</b>	24	105	4 Diff Simultaneous	Serial, SPI w/FSYNC	2.5	Ext	0.001	80-400	TQFP-64	\$18.00
<b>ADS1271</b>	24	105	1 Diff	Serial, SPI w/FSYNC	2.5	Ext	0.0015	35-100	TSSOP-16	\$5.90
ADS1252	24	41	1 SE/1 Diff	Serial	5	Ext	0.0015	40	SOIC-8	\$5.60
<b>ADS1256</b>	24	30	8 SE/4 Diff	Serial, SPI	PGA (1-64), 5V	Ext	0.001	35	SSOP-28	\$6.95
<b>ADS1255</b>	24	30	2 SE/1 Diff	Serial, SPI	PGA (1-64), 5V	Ext	0.001	35	SSOP-20	\$6.50
ADS1253	24	20	4 SE/4 Diff	Serial	5	Ext	0.0015	7.5	SSOP-16	\$6.70
ADS1254	24	20	4 SE/4 Diff	Serial	5	Ext	0.0015	4	SSOP-20	\$6.70
ADS1251	24	20	1 SE/1 Diff	Serial	5	Ext	0.0015	7.5	SOIC-8	\$5.60
ADS1210/11	24	16	1 SE/1 Diff 4 SE/4 Diff	Serial, SPI	PGA (1-16), 5	Int/Ext	0.0015	27.5	SOIC-18, -24, SSOP-28	\$11.00
ADS1216	24	0.78	8 SE/4 Diff	Serial, SPI	PGA (1-128), 2.5	Int/Ext	0.0015	0.6	TQFP-48	\$5.00
ADS1217	24	0.78	8 SE/4 Diff	Serial, SPI	PGA (1-128), 5	Int/Ext	0.0012	0.8	TQFP-48	\$5.00
ADS1218	24	0.78	8 SE/4 Diff	Serial, SPI	PGA (1-128), 2.5	Int/Ext	0.0015	0.8	TQFP-48	\$5.50
ADS1224	24	0.24	4 SE/4 Diff	Serial	5	Ext	0.0015	0.5	TSSOP-20	\$3.25
ADS1222	24	0.24	2 SE/2 Diff	Serial	5	Ext	0.0015	0.5	TSSOP-14	\$2.95
<b>ADS1234</b>	24	0.08	4 SE/4 Diff	Serial	PGA (1-128), 2.5	Ext	0.0015	3	TSSOP-28	\$4.50
<b>ADS1232</b>	24	0.08	2 SE/2 Diff	Serial	PGA (1-128), 2.5	Ext	0.0015	3	TSSOP-24	\$3.90
<b>ADS1226</b>	24	0.08	2 Diff	Serial	5	Ext	0.0015	0.5	QFN-16	\$2.95
<b>ADS1225</b>	24	0.08	1 Diff	Serial	5	Ext	0.0015	0.5	QFN-16	\$2.75
ADS1241	24	0.015	8 SE/4 Diff	Serial, SPI	PGA (1-128), 2.5	Ext	0.0015	0.5	SSOP-28	\$4.20
ADS1243	24	0.015	8 SE/4 Diff	Serial, SPI	PGA (1-128), 2.5	Ext	0.0015	0.6	TSSOP-20	\$3.95
ADS1240	24	0.015	4 SE/2 Diff	Serial, SPI	PGA (1-128), 2.5	Ext	0.0015	0.6	SSOP-24	\$3.80
ADS1242	24	0.015	4 SE/2 Diff	Serial, SPI	PGA (1-128), 2.5	Ext	0.0015	0.6	TSSOP-16	\$3.60
ADS1244	24	0.015	1 SE/1 Diff	Serial	5	Ext	0.0008	0.3	MSOP-10	\$2.95
ADS1245	24	0.015	1 SE/1 Diff	Serial	2.5	Ext	0.0015	0.5	MSOP-10	\$3.10
ADS1212/13	22	6.25	1 SE/1 Diff 4 SE/4 Diff	Serial, SPI	PGA (1-16), 5	Int/Ext	0.0015	1.4	SOIC-18, -24, SSOP-28	\$10.00
ADS1250	20	25	1 SE/1 Diff	Serial, SPI	PGA (1-8), 4	Ext	0.003	75	SOIC-16	\$6.95
<b>ADS1230</b>	20	0.08	1 SE/1 Diff	Serial	0.02	Ext	0.003	3	TSSOP-24	\$2.50
<b>ADS1112</b>	16	0.24	3 SE/2 Diff	Serial, I <sup>2</sup> C	PGA (1-8), 2.048	Int	0.01	0.7	MSOP-10, SON-10	\$2.65
<b>ADS1110</b>	16	0.24	1 SE/1 Diff	Serial, I <sup>2</sup> C	PGA (1-8), 2.048	Int	0.01	0.7	SOT23-6	\$1.95
<b>ADS1100</b>	16	0.128	1 SE/1 Diff	Serial, I <sup>2</sup> C	PGA (1-8), V <sub>DD</sub>	Ext	0.0125	0.3	SOT23-6	\$1.80
TLC7135	14	3	1 SE/1 Diff	3 1/2 Digit MUX BCD	$\pm V_{REF}$	Ext	0.005	5	PDIP-28, SOIC-28	\$1.95
<b>ADS1010</b>	12	0.25	1 SE/1 Diff	Serial, I <sup>2</sup> C	PGA(1-8), 2.048	Int	0.01	0.7	SOT23-6	\$1.10
<b>ADS1012</b>	12	0.24	3 SE/1 Diff	Serial, I <sup>2</sup> C	PGA(1-8), 2.048	Int	0.01	0.7	MSOP-10, SON-10	\$1.45
<b>ADS1000</b>	12	0.128	1 SE/1 Diff	Serial, I <sup>2</sup> C	PGA(1-8), V <sub>DD</sub>	Ext	0.0125	0.3	SOT23-6	\$0.99

**Delta-Sigma ( $\Delta\Sigma$ ) ADCs for Measuring Low-Level Currents (Photodiodes)**

DDC101	20	10	1	Serial	500pC	Ext	0.025	170	SOIC-24	\$25.00
<b>DDC232</b>	20	3	32	Serial	12-350pC	Ext	0.025	224-320	BGA-64	\$75.00
<b>DDC118</b>	20	3	8	Serial	12-350pC	Ext	0.025	110	QFN-48	\$32.00
DDC114	20	3	4	Serial	12-350pC	Ext	0.025	55	QFN-48	\$18.00
DDC112	20	3	2	Serial	50-1000pC	Ext	0.025	80	SOIC-28	\$12.10

**Wide Bandwidth Delta-Sigma ( $\Delta\Sigma$ ) ADCs**

<b>ADS1274</b>	24	105	4 Diff	Serial	2.5	—	—	80-400	TQFP-64	\$18.00
<b>ADS1271</b>	24	105	1 Diff	Serial	2.5	—	—	35-100	TSSOP-16	\$5.90
ADS1625	18	1250	1 Diff	P18	3.75	—	—	520	TQFP-64	\$24.95
ADS1626	18	1250	1 Diff	P18 w/FIFO	3.75	—	—	520	TQFP-64	\$25.70
<b>ADS1610</b>	16	10000	1 Diff	P16	3	—	—	1000	TQFP-64	\$29.95
ADS1605	16	5000	1 Diff	P16	3.75	—	—	570	TQFP-64	\$24.95
ADS1606	16	5000	1 Diff	P16 w/FIFO	3.75	—	—	570	TQFP-64	\$25.70
ADS1602	16	2500	1 Diff	Serial	3	—	—	550	TQFP-48	\$19.95
ADS1601	16	1250	1 Diff	Serial	3	—	—	350	TQFP-48	\$12.95

\*Suggested resale price in U.S. dollars in quantities of 1,000.

New products are listed in bold red. Preview products are listed in bold blue.



MicroSystem products combine the use of a well-established microcontroller core with best-of-class analog performance. The microcontroller core and the analog core are integrated together with high-performance peripherals to make a highly integrated system solution. Therefore, MicroSystem products fit well with applications that require high analog performance and high integration.

Integration plays a critical role in high-precision systems. Integration can solve technical problems such as reducing system level performance problems, noise, interference, interface and layout issues. Integration can also reduce the research and development time by simplifying the parts search, prototyping and design. Furthermore, the key

performance parameters of the system are localized, making development and debug more efficient. The benefit is a more robust, reliable and predictable system.

The technical information and design considerations for the analog cores, described in other sections, which are integrated into the MicroSystem product, still apply. However, the MicroSystem products offer increased flexibility in controlling these parameters to meet the specific needs of the application. For instance, with the  $\Delta\Sigma$  ADC, the modulator clock can be controlled directly to make speed versus resolution trade-offs. This makes the MicroSystem product a powerful, customizable solution.

### Design Considerations

(see data converter architecture section)

**MIPS**—millions of instructions per second.

**Instruction cycle**—the length of time required to fetch, decode, execute and store the result of an instruction.

**Endurance**—flash endurance is defined as the number of erase/write cycles that the memory can withstand without a failure.

## Precision ADC and DACs with 8051 Microcontroller and Flash Memory

### MSC1201, MSC1202

Get samples, datasheets, EVMs and app reports at: [www.ti.com/sc/device/MSC1201](http://www.ti.com/sc/device/MSC1201) and [www.ti.com/sc/device/MSC1202](http://www.ti.com/sc/device/MSC1202)

### Key Features

- MSC1201: 24-bits no missing codes, 22-bits effective resolution at 10Hz, low noise: 75nV
- MSC1202: 16-bits no missing codes, 16-bits effective resolution at 200Hz, noise: 600nV
- PGA from 1 to 128
- Precision on-chip voltage reference
- 6 differential/single-ended channels
- Microcontroller core:
  - 8051-compatible
  - High-speed: 4 clocks per instruction cycle
  - DC to 33MHz
- Memory:
  - 4kB or 8kB Flash memory
  - Flash memory partitioning
- Peripheral features: 16 digital I/O pins

### Applications

- Industrial process control
- Instrumentation
- Liquid/gas chromatography
- Blood analysis
- Smart transmitters
- Portable applications
- DAS systems

The MSC1201Yx/MSC1202Yx are completely integrated families of mixed-signal devices incorporating a high-resolution,  $\Delta\Sigma$  ADC, 8-bit IDAC, 6-channel multiplexer, burnout detect current sources, selectable buffered input, offset DAC, PGA, temperature sensor, voltage reference, 8-bit microcontroller, Flash program memory, Flash data memory and Data SRAM. The microcontroller core is an optimized 8051 core that executes up to three times faster than the standard 8051 core, given the same clock source. This makes it possible to run the device at a lower external clock frequency and achieve the same performance at lower power than the standard 8051 core. The MSC1201Yx/MSC1202Yx are designed for high-resolution measurement applications.

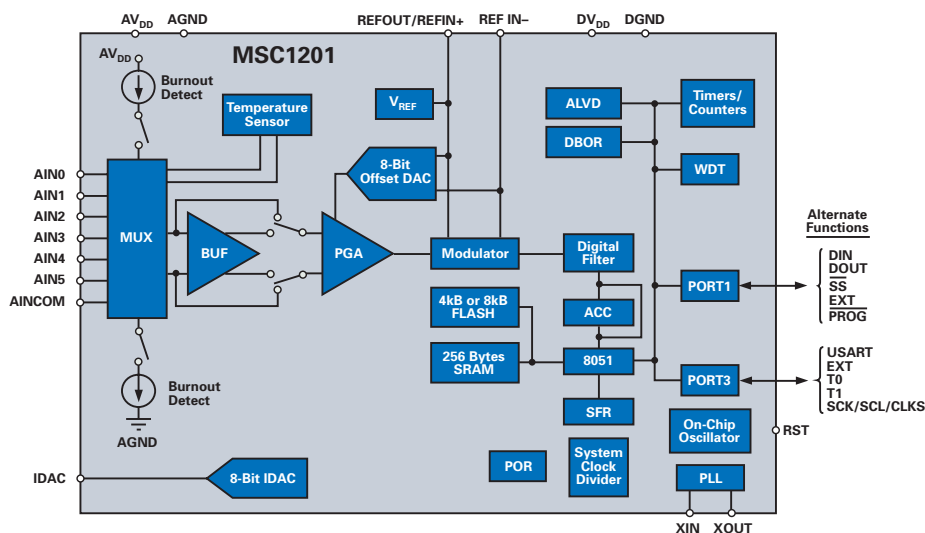

MSC1201 functional block diagram.





## Intelligent ADCs

### 8051-Based Intelligent $\Delta\Sigma$ MicroSystems Selection Guide

Device	ADC Res. (Bits)	Sample Rate (kSPS)	Number of Input Channels	Input Voltage (V)	$V_{REF}$	Program Flash Memory (kB)	SRAM (kB)	DAC Output	DAC Res. (Bits)	Power (mW/V)	Package	Price*
<b>MSC1200</b>	24	1	8 Diff/8 SE	PGA (1-128), 2.5	Int/Ext	4/8	0.1	IDAC	8	3/2.7-5.25	TQFP-48	\$5.95
<b>MSC1201</b>	24	1	6 Diff/6 SE	PGA (1-128), 2.5	Int/Ext	4/8	0.1	IDAC	8	3/2.7-5.25	QFN-36	\$5.60
MSC1210	24	1	8 Diff/8 SE	PGA (1-128), 2.5	Int/Ext	4/8/16/32	1.2	PWM	16	4/2.7-5.25	TQFP-64	\$8.95
MSC1211	24	1	8 Diff/8 SE	PGA (1-128), 2.5	Int/Ext	4/8/16/32	1.2	I/VDAC	16x4	4/2.7-5.25	TQFP-64	\$17.50
MSC1212	24	1	8 Diff/8 SE	PGA (1-128), 2.5	Int/Ext	4/8/16/32	1.2	I/VDAC	16x4	4/2.7-5.25	TQFP-64	\$16.95
MSC1213	24	1	8 Diff/8 SE	PGA (1-128), 2.5	Int/Ext	4/8/16/32	1.2	I/VDAC	16x2	4/2.7-5.25	TQFP-64	\$12.65
MSC1214	24	1	8 Diff/8 SE	PGA (1-128), 2.5	Int/Ext	4/8/16/32	1.2	I/VDAC	16x2	4/2.7-5.25	TQFP-64	\$12.15
<b>MSC1202</b>	16	2	6 Diff/6 SE	PGA (1-128), 2.5	Int/Ext	4/8	0.2	IDAC	8	3/2.7-5.25	QFN-36	\$4.60

\*Suggested resale price in U.S. dollars in quantities of 1,000 for base memory option.

New products are listed in bold red.

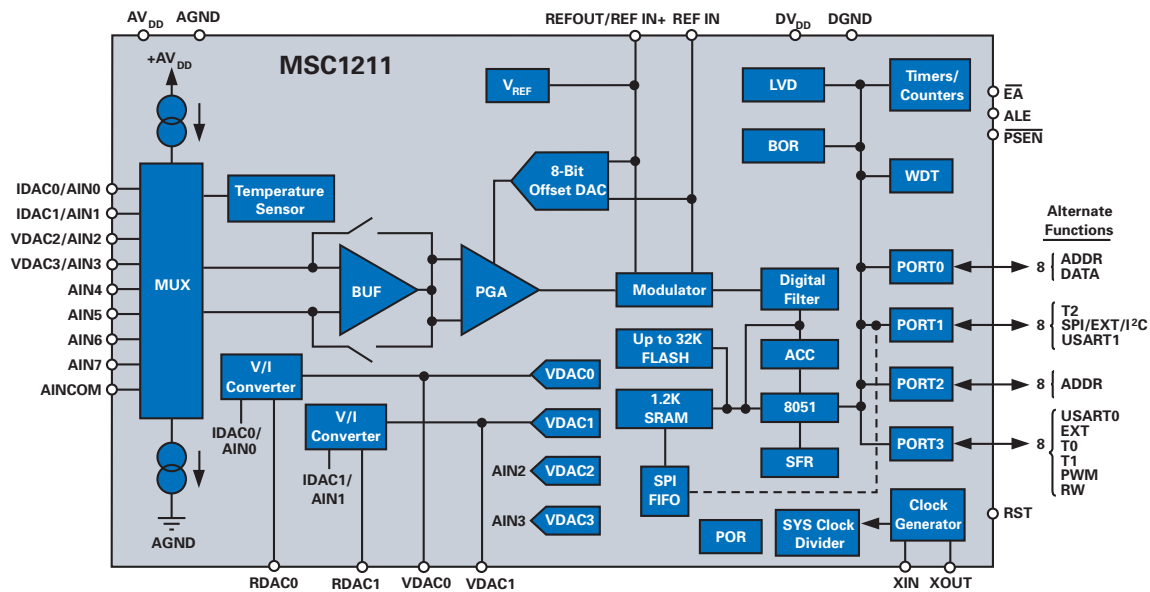

MSC1211 functional block diagram.

## SAR ADCs



Successive-approximation register (SAR) converters are frequently the architecture of choice for medium-to-high-resolution applications with medium sampling rates. SAR ADCs range in resolution from 8- to 18-bits with speeds typically less than 10MSPS. They provide low power consumption and a small form factor.

A SAR converter operates on the same principle as a balance scale. On the scale, an unknown weight is placed on one side of the balance point, while known weights are placed on the other side and rejected or kept until the two sides are perfectly balanced. The unknown weight can then be measured by totaling up the kept, known weights. In the SAR converter, the input signal is the unknown weight, which is sampled and held. This voltage is then compared to successive known voltages, and the results are output by the converter. Unlike the weigh scale, conversion occurs very quickly through the use of charge redistribution techniques.

Because the SAR ADC samples the input signal and holds the sampled value until conversion is complete, this architecture does not make any assumptions about the nature of the input signal, and the signal therefore does not need to be continuous. This makes the SAR architecture ideal for applications where a multiplexer may be used prior to the converter, or for applications where the converter may only need to make a measurement once every few seconds, or for applications where a "fast" measurement is required. The conversion time remains the same in all cases, and has little sample-to-conversion latency compared to a pipeline or delta-sigma converter. SAR converters are ideal for real-time applications such as industrial control, motor control, power management, portable/battery-powered instruments, PDAs, test equipment and data/signal acquisition.

## Technical Information

Modern SAR ADCs use a sample capacitor that is charged to the voltage of the input signal. Due to the ADC's input capacitance, input impedance, and external circuitry, a settling time will be required for the sample capacitor's voltage to match the measured input voltage.

Minimizing the external circuitry's source impedance is one way to minimize this settling time, assuring that the input signal is accurately acquired within the ADC's acquisition time. A more troublesome design constraint, however, is the dynamic load that the SAR ADC's input presents to the driving circuitry. The op amp driver to the ADC input must be able to handle this dynamic load and settle to the desired accuracy within the required acquisition time.

The SAR ADC's reference input circuitry presents a similar load to the reference voltage. While the reference voltage is supposed to be a very stable DC voltage, the dynamic load that the ADC's reference input presents makes achieving this goal somewhat difficult. Thus, buffer circuitry is required for the reference voltage, and the op amp used for this has similar requirements as that used for driving the ADC input; in fact, the requirements on the op amp may be even higher than for the input signal as the reference input must be settled within one clock cycle. Some converters have this reference buffer amplifier built in.

Buffering these inputs using op amps with a low, wideband output impedance is the best way to preserve accuracy with these converters.

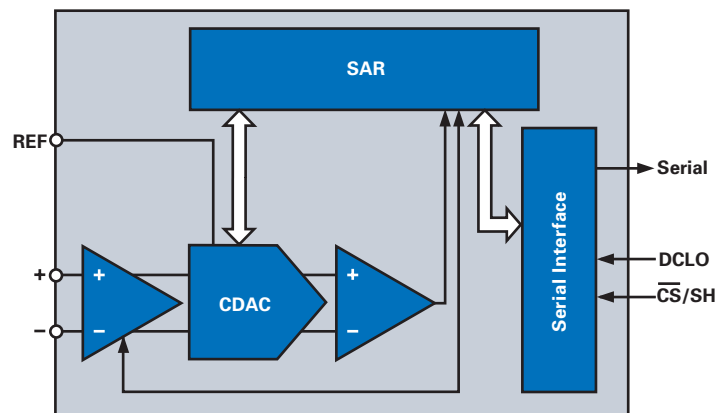

*In a SAR ADC, the bits are decided by a single high-speed, high-accuracy comparator bit by bit, from the MSB down to the LSB. This is done by comparing the analog input with a DAC whose output is updated by previously decided bits and successively approximates the analog input.*

## → SAR ADCs

### 12- and 16-Bit, $\pm 10\text{V}$ Input, Single-Supply Family of SAR ADCs

**ADS8504, ADS8505, ADS8508, ADS8509**

**NEW**

Get samples, datasheets, EVMs and app reports at: [www.ti.com/sc/device/PARTnumber](http://www.ti.com/sc/device/PARTnumber) (Replace **PARTnumber** with **ADS8504, ADS8505, ADS8508, ADS8509**)

#### Key Features

- Resolution: 12-bits (ADS8504/05)  
16-bits (ADS8508/09)
- Sample rate: 250kHz
- Input ranges:  $\pm 10\text{V}$  (ADS8504/05)  
 $4\text{V}, 5\text{V}, 10\text{V}, \pm 3.3\text{V}, \pm 5\text{V}, \pm 10\text{V}$  (ADS8508/09)
- SINAD: 73dB with 45kHz input
- Single supply: 5V
- Low power: 70mW (typ) at 250kSPS
- Internal/external reference
- Full parallel data output (ADS8504/05)  
SPI-compatible serial output with daisy-chain (TAG) feature (ADS8508/09)
- Packaging: SOIC-28, SSOP-28 and SO-20

#### Applications

- Industrial process control
- Data acquisition systems
- Medical equipment
- Instrumentation
- Digital signal processing

The ADS850x family devices are SAR ADCs complete with S/H, reference, clock, interface for microprocessor use and 3-state output drivers. The ADS8508 and ADS8509 also provide an output synchronization pulse for ease of use with standard DSP processors. An innovative design allows operation from a single 5V supply, while keeping power dissipation below 100mW.

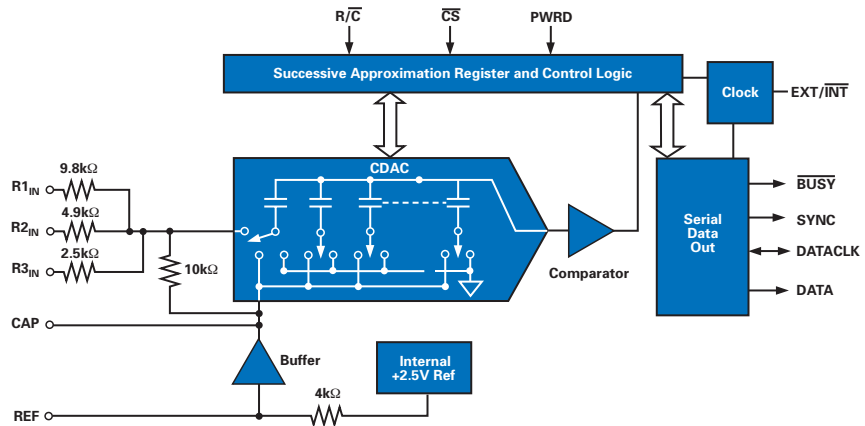

ADS850x functional block diagram.

### 16-Bit, 600kSPS, Pseudo-Differential Input, $\mu\text{Power}$ ADCs

**ADS8370, ADS8372**

**NEW**

Get samples, datasheets, EVMs and app reports at: [www.ti.com/sc/device/ADS8370](http://www.ti.com/sc/device/ADS8370) and [www.ti.com/sc/device/ADS8372](http://www.ti.com/sc/device/ADS8372)

#### Key Features

- Sample rate: 600kSPS
- INL:  $\pm 0.4\text{LSB}$  (typ),  $\pm 0.75\text{LSB}$  (max)
- SINAD: 93.5dB
- SFDR: 120dB at  $f_1 = 1\text{kHz}$
- Pseudo-differential input (ADS8370):  
 $0\text{V}$  to  $4.2\text{V}$
- Pseudo-bipolar input (ADS8372):  
up to  $\pm 4.2\text{V}$
- Low power:
  - 110mW at 600kHz
  - 15mW during nap mode
  - 10 $\mu\text{W}$  during power down
- Packaging: 28-lead 6x6 QFN

#### Applications

- Medical instruments
- Optical networking
- Transducer interface
- High-accuracy data acquisition systems
- Magnetometers

The ADS8370 and ADS8372 are high-performance, 16-bit, 600kSPS ADCs complete with inherent sample/hold, onboard reference and a high-speed, CMOS serial interface with clock speeds up to 40MHz. The ADS8370 offers unipolar (pseudo-differential) input, and the ADS8372 offers a fully differential, pseudo-bipolar input. Both offer a wide digital supply, zero latency and ensure 16-bit no missing code operation over the entire industrial ( $-40^\circ\text{C}$  to  $+85^\circ\text{C}$ ) temperature range.

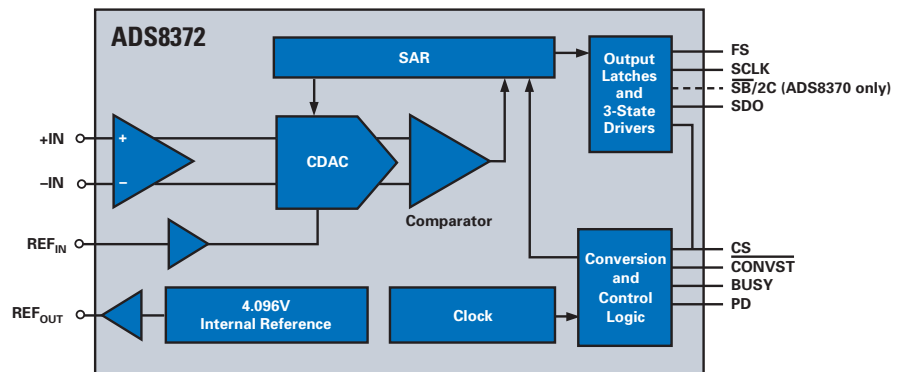

ADS8370 and ADS8372 functional block diagram.



NEW

## 18-Bit, 1MSPS, High-Performance ADCs

### ADS8481, ADS8482

Get samples, datasheets, EVMs and app reports at: [www.ti.com/sc/device/ADS8481](http://www.ti.com/sc/device/ADS8481) and [www.ti.com/sc/device/ADS8482](http://www.ti.com/sc/device/ADS8482)

#### Key Features

- 18-bits, 1MSPS sample rate
- 18-bit NMC ensured over temperature
- Zero latency
- ADS8481: unipolar single-ended input range: 0V to  $V_{REF}$
- ADS8482: bipolar differential input range:  $V_{REF}$  to  $-V_{REF}$
- Low power: 250mW at 1MSPS
- High-speed parallel interface
- Wide digital supply: 2.7V to  $\sim$ 5.25V
- 8-/16-/8-bit bus transfer
- Packaging: TQFP-48 or QFN-48 (7x7)

#### Applications

- Medical instrumentation
- Optical networking
- Transducer interface
- High-accuracy data acquisition systems
- Magnetometers

The ADS8481 and ADS8482 feature 250mW at 1MSPS low power consumption and are complete with sample/hold and internal 4.096V reference. The ADS8481 has a pseudo-differential unipolar input and the ADS8482 has a pseudo-bipolar, fully differential input. Both offer a full 18-bit interface, a 16-bit option where data is read using two read cycles, or an 8-bit bus option using three read cycles.

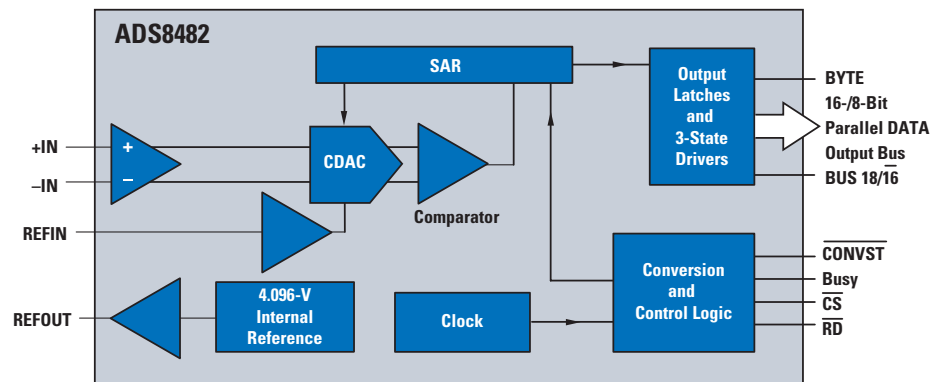

ADS8482 functional block diagram.

## 16-Bit, 500kHz, Low Power, Single/Dual Unipolar Input ADCs

### ADS8327, ADS8328

NEW

Get samples, datasheets, EVMs and app reports at: [www.ti.com/sc/device/ADS8327](http://www.ti.com/sc/device/ADS8327) and [www.ti.com/sc/device/ADS8328](http://www.ti.com/sc/device/ADS8328)

#### Key Features

- Excellent DC performance:
  - INL:  $\pm$ 2LSB
  - DNL:  $\pm$ 1LSB
- Excellent AC performance:
  - SNR: 91dB
  - SFDR: 100dB
  - THD:  $-$ 96dB
- Built-in conversion clock; SCLK up to 42MHz
- Analog supply: 2.7V to 5.5V
- SPI/DSP-compatible serial interface
- Unipolar input range: 0V to  $V_{REF}$
- Comprehensive power-down modes: Deep, Nap, Autanap
- Packaging: TSSOP-16, 4x4 QFN

The ADS8327 and ADS8328 are low power (10.6mW at 500kHz) ADCs with unipolar input and inherent sample and hold. The ADS8328 includes a 2:1 input MUX with programmable option of TAG bit output. Both offer high speed, wide voltage serial interface and are capable of chain mode operation when multiple converters are used.

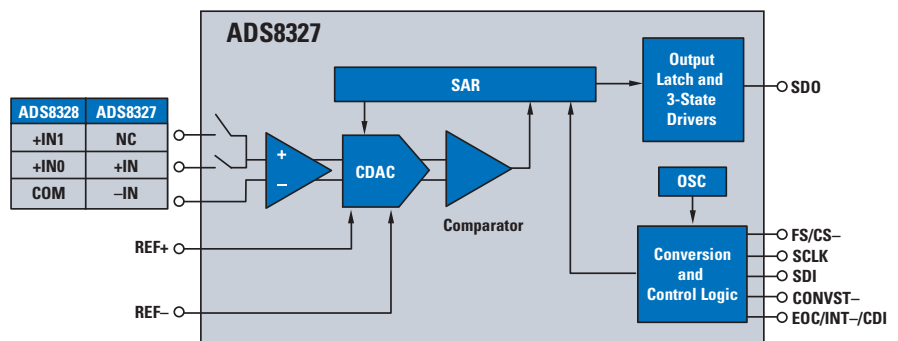

ADS8327 functional block diagram.

#### Applications

- Communications
- Medical instruments
- Magnetometers
- Industrial Process control
- ATE



## SAR ADCs

Device	Res. (Bits)	Sample Rate (kSPS)	Number of Input Channels	Interface	Input Voltage (V)	V <sub>REF</sub>	Linearity (%)	NMC	SINAD (dB)	Power (mW)	Package(s)	Price*
<b>ADS8482</b>	18	1000	1 Diff	P8/P16/P18	$\pm V_{REF}$ (4.1V) at $V_{REF}/2$	Int/Ext	0.0011	18	98	220	7x7 QFN, TQFP-48	\$20.25
<b>ADS8481</b>	18	1000	1 SE, 1 PDiff	P8/P16/P18	$V_{REF}$ (4.1)	Int/Ext	0.0013	18	92	220	7x7 QFN, TQFP-48	\$19.80
<b>ADS8382</b>	18	600	1 Diff	Serial, SPI	$\pm V_{REF}$ (4.1V) at $V_{REF}/2$	Int/Ext	0.0012	18	96	110	6x6 QFN-28	\$16.95
<b>ADS8380</b>	18	600	1 SE, 1 PDiff	Serial, SPI	$V_{REF}$	Int/Ext	0.0015	18	91	110	6x6 QFN-28	\$16.50
<b>ADS8381</b>	18	580	1 SE, 1 PDiff	P8/P16/P18	$V_{REF}$ (4.1)	Ext	0.0019	18	88	115	TQFP-48	\$16.65
<b>ADS8383</b>	18	500	1 SE, 1 PDiff	P8/P16/P18	$V_{REF}$ (4.1)	Ext	0.0026	18	87	110	TQFP-48	\$15.75
<b>ADS8422</b>	16	4000	1 Diff	P8/P16	$\pm V_{REF}$ (4.1V) at $V_{REF}/2$	Int/Ext	0.003	16	92	160	7x7 QFN, TQFP-48	\$23.95
<b>ADS8413</b>	16	2000	1 Diff	Serial, LVDS	$\pm V_{REF}$ (4.1V) at $V_{REF}/2$	Int/Ext	0.0038	16	92	290	7x7 QFN-48	\$24.05
ADS8412	16	2000	1 Diff	P8/P16	$\pm V_{REF}$ (4.1V) at $V_{REF}/2$	Int	0.0038	16	88	175	TQFP-48	\$23.05
<b>ADS8410</b>	16	2000	1 SE, 1 PDiff	Serial, LVDS	$V_{REF}$ (4.1)	Int/Ext	0.0038	16	87	290	7x7 QFN-48	\$23.00
ADS8411	16	2000	1 SE, 1 PDiff	P8/P16	$V_{REF}$	Int	0.0038	16	85	175	TQFP-48	\$22.00
ADS8402	16	1250	1 Diff	P8/P16	$\pm V_{REF}$ (4.1V) at $V_{REF}/2$	Int	0.0053	16	88	155	TQFP-48	\$13.15
<b>ADS8406</b>	16	1250	1 Diff	P8/P16	$\pm V_{REF}$ (4.1V) at $V_{REF}/2$	Int/Ext	0.003	16	90	155	TQFP-48	\$14.70
ADS8401	16	1250	1 SE, 1 PDiff	P8/P16	$V_{REF}$	Int	0.0053	16	85	155	TQFP-48	\$12.55
<b>ADS8405</b>	16	1250	1 SE, 1 PDiff	P8/P16	$V_{REF}$	Int/Ext	0.003	16	85	155	TQFP-48	\$14.10
<b>ADS8329</b>	16	1000	1 SE, 1 PDiff	Serial, SPI	$V_{REF}$ (4.2V at 5V, 2.5V at 2.7V Supply)	Ext	0.0045	16	85	20	TSSOP-16	\$11.25
<b>ADS8330</b>	16	1000	2 SE, 2 PDiff	Serial, SPI	$V_{REF}$ (4.2V at 5V, 2.5V at 2.7V Supply)	Ext	0.0045	16	85	20	TSSOP-16	\$12.00
ADS8371	16	750	1 SE, 1 PDiff	P8/P16	$V_{REF}$	Ext	0.0023	16	87.6	130	TQFP-48	\$12.00
<b>ADS8372</b>	16	600	1 Diff	Serial, SPI	$\pm V_{REF}$ (4.2V) at $V_{REF}/2$	Int/Ext	0.0012	16	93.5	110	6x6 QFN-28	\$13.00
<b>ADS8370</b>	16	600	1 SE, 1 PDiff	Serial, SPI	$V_{REF}$	Int/Ext	0.0015	16	90	110	6x6 QFN-28	\$12.50
ADS8323	16	500	1 Diff	P8/P16	$\pm 2.5V$ at 2.5	Int/Ext	0.009	15	83	85	TQFP-32	\$7.10
ADS8322	16	500	1 PDiff	P8/P16	5	Int/Ext	0.009	15	83	85	TQFP-32	\$7.10
<b>ADS8327</b>	16	500	1 SE, 1 PDiff	Serial, SPI	$V_{REF}$ (4.2V at 5V, 2.5V at 2.7V Supply)	Ext	0.00305	16	88.5	10.6	TSSOP-16	\$8.50
<b>ADS8328</b>	16	500	2 SE, 2 PDiff	Serial, SPI	$V_{REF}$ (4.2V at 5V, 2.5V at 2.7V Supply)	Ext	0.00305	16	88.5	10.6	TSSOP-16	\$9.30
ADS8361	16	500	2 x 2 Diff	Serial, SPI	$\pm 2.5V$ at $\pm 2.5$	Int/Ext	0.00375	14	83	150	SSOP-24	\$8.75
<b>ADS8509</b>	16	250	1 SE	Serial, SPI	+4, 10, $\pm 3.3$ , 5, 10	Int/Ext	0.003	16	86	70	SOIC-20, SSOP-28	\$12.95
<b>ADS8505</b>	16	250	1 SE	P16	$\pm 10$	Int/Ext	0.003	16	86	70	SOIC-28, SSOP-28	\$12.95
ADS7811	16	250	1 SE	P16	$\pm 2.5$	Int/Ext	0.006	15	87	200	SOIC-28	\$36.15
ADS7815	16	250	1 SE	P16	$\pm 2.5$	Int/Ext	0.006	15	84	200	SOIC-28	\$21.30
<b>ADS8365</b>	16	250	1 x 6 Diff	P16	$\pm 2.5V$ at $\pm 2.5$	Int/Ext	0.0045	15	82.5	200	TQFP-64	\$17.00
ADS8364	16	250	1 x 6 Diff	P16	$\pm 2.5V$ at $\pm 2.5$	Int/Ext	0.0045	14	82.5	413	TQFP-64	\$18.10
ADS8342	16	250	SE	P8/P16	$\pm 2.5$	Ext	0.006	16	85	200	TQFP-48	\$11.30
<b>ADS8326</b>	16	200	1 SE, 1 PDiff	Serial, SPI	$V_{REF}$	Ext	0.003	16	91	6	VSSOP-8, QFN-8	\$5.90
TLC4545	16	200	1 PDiff	Serial, SPI	$V_{REF}$	Ext	0.0038	16	84.5	17.5	SOIC-8, VSSOP-8	\$6.85
TLC4541	16	200	1 SE	Serial, SPI	$V_{REF}$	Ext	0.0038	16	84.5	17.5	SOIC-8, VSSOP-8	\$6.85
ADS8321	16	100	1 Diff	Serial, SPI	$\pm V_{REF}$ at $\pm V_{REF}$	Ext	0.012	15	84	5.5	VSSOP-8	\$5.15
ADS8320	16	100	1 SE, 1 PDiff	Serial, SPI	$V_{REF}$	Ext	0.012	15	84	1.95	VSSOP-8	\$5.15
ADS8325	16	100	1 SE, 1 PDiff	Serial, SPI	$V_{REF}$	Ext	0.006	16	91	2.25	VSSOP-8, QFN-8	\$5.90
ADS7805	16	100	1 SE	P8/P16	$\pm 10$	Int/Ext	0.0045	16	86	81.5	PDIP-28, SOIC-28	\$21.80
ADS7809	16	100	1 SE	Serial, SPI	+4, 10, $\pm 3.3$ , 5, 10	Int/Ext	0.0045	16	88	81.5	SOIC-20	\$21.80
ADS8341	16	100	4 SE/2 Diff	Serial, SPI	$V_{REF}$	Ext	0.006	15	86	3.6	SSOP-16	\$7.40
ADS8343	16	100	4 SE/2 Diff	Serial, SPI	$\pm V_{REF}$ at $V_{REF}$	Ext	0.006	15	86	3.6	SSOP-16	\$7.45
ADS8344	16	100	8 SE/4 Diff	Serial, SPI	$V_{REF}$	Ext	0.006	15	86	3.6	SSOP-20	\$8.00
ADS8345	16	100	8 SE/4 Diff	Serial, SPI	$\pm V_{REF}$ at $V_{REF}$	Ext	0.006	15	85	3.6	SSOP-20	\$8.00
ADS7807	16	40	1 SE	Serial, SPI/P8	4, 5, $\pm 10$	Int/Ext	0.0022	16	88	28	PDIP-28, SOIC-28	\$27.40
ADS7813	16	40	1 SE	Serial, SPI	+4, 10, $\pm 3.3$ , 5, 10	Int/Ext	0.003	16	89	35	PDIP-16, SOIC-16	\$21.30
ADS7825	16	40	4 SE	Serial, SPI/P8	$\pm 10$	Int/Ext	0.003	16	83	50	PDIP-28, SOIC-28	\$29.55
ADS7891	14	3000	1 SE	P8/P14	2.5	Int	0.009	14	78	85	TQFP-48	\$10.50
ADS7890	14	1250	1 SE	Serial, SPI	2.5	Int	0.009	14	77	45	TQFP-48	\$10.50
TLC3545	14	200	1 Diff	Serial, SPI	$V_{REF}$	Ext	0.006	14	81.5	17.5	SOIC-8, VSSOP-8	\$5.00
TLC3541	14	200	1 SE	Serial, SPI	$V_{REF}$	Ext	0.006	14	81.5	17.5	SOIC-8, VSSOP-8	\$5.00

\*Suggested resale price in U.S. dollars in quantities of 1,000.

New products are listed in bold red.  
Preview products are listed in bold blue.



## SAR ADCs (Continued)



Device	Res. (Bits)	Sample Rate (kSPS)	Number of Input Channels	Interface	Input Voltage (V)	V <sub>REF</sub>	Linearity (%)	NMC	SINAD (dB)	Power (mW)	Package(s)	Price*
TLC3544	14	200	4 SE/2 Diff	Serial, SPI	4	Int/Ext	0.006	14	81	20	SOIC-20, TSSOP-20	\$6.00
TLC3578	14	200	8 SE	Serial, SPI	±10	Ext	0.006	14	79	29	SOIC-24, TSSOP-24	\$8.65
TLC3548	14	200	8 SE/4 Diff	Serial, SPI	4	Int/Ext	0.006	14	81	20	SOIC-24, TSSOP-24	\$6.40
ADS8324	14	50	1 Diff	Serial, SPI	±V <sub>REF</sub> at +V <sub>REF</sub>	Ext	0.012	14	78	2.5	VSSOP-8	\$4.15
ADS7871	14	40	8 SE/4 Diff	Serial, SPI	PGA (1, 2, 4, 8, 10, 16, 20)	Int	0.03	13	—	6	SSOP-28	\$5.00
ADS7881	12	4000	1 SE	P8/P12	2.5	Int	0.024	12	71.5	95	7x7 QFN, TQFP-48	\$7.35
<b>ADS7886</b>	12	1000	1 SE, 1 PDiff	Serial, SPI	V <sub>DD</sub> (2.35V to 5.25V)	Ext (V <sub>DD</sub> )	0.036	12	71.2	7.5	SOT23-6, SC-70	\$1.70
<b>ADS7869</b>	12	1000	12 Diff	Serial, SPI/P12	±2.5 at +2.5	Int/Ext	0.048	11	—	175	TQFP-100	\$14.60
ADS7810	12	800	1 SE	P12	±10	Int/Ext	0.018	12	71	225	SOIC-28	\$27.80
ADS7835	12	500	1 Diff	Serial, SPI	±2.5	Int	0.024	12	72	17.5	VSSOP-8	\$2.75
ADS7818	12	500	1 PDiff	Serial, SPI	5	Int	0.024	12	70	11	PDIP-8, VSSOP-8	\$2.50
ADS7834	12	500	1 PDiff	Serial, SPI	2.5	Int	0.024	12	70	11	VSSOP-8	\$2.45
ADS7861	12	500	2 x 2 Diff	Serial, SPI	±2.5 at +2.5	Int/Ext	0.024	12	70	25	SSOP-24	\$4.05
ADS7862	12	500	2 x 2 Diff	P12	±2.5 at +2.5	Int/Ext	0.024	12	71	25	TQFP-32	\$5.70
ADS7864	12	500	3 x 2 Diff	P12	±2.5 at +2.5	Int/Ext	0.024	12	71	52.5	TQFP-48	\$6.65
ADS7852	12	500	8 SE	P12	5	Int/Ext	0.024	12	72	13	TQFP-32	\$3.40
TLC2555	12	400	1 PDiff	Serial, SPI	V <sub>REF</sub>	Ext	0.024	12	72	15	SOIC-8, VSSOP-8	\$3.95
TLC2551	12	400	1 SE	Serial, SPI	V <sub>REF</sub>	Ext	0.024	12	72	15	SOIC-8, VSSOP-8	\$3.95
TLC2552	12	400	2 SE	Serial, SPI	V <sub>REF</sub>	Ext	0.024	12	72	15	SOIC-8, VSSOP-8	\$3.95
TLC2554	12	400	4 SE	Serial, SPI	4	Int/Ext	0.024	12	71	9.5	SOIC-16, TSSOP-16	\$5.30
TLC2558	12	400	8 SE	Serial, SPI	4	Int/Ext	0.024	12	71	9.5	SOIC-20, TSSOP-20	\$5.30
ADS7800	12	333	1 SE	P8/P12	±5, 10	Int	0.012	12	72	135	CDIP SB-24, PDIP-24	\$30.50
<b>ADS8508</b>	12	250	1 SE	Serial, SPI	+4, 10, ±3.3, 5, 10	Int/Ext	0.011	12	73	70	SSOP-28, SOIC-20	\$10.50
<b>ADS8504</b>	12	250	1 SE	P8/P16	±10	Int/Ext	0.011	12	72	70	SSOP-28, SOIC-28	\$10.50
ADS7817	12	200	1 Diff	Serial, SPI	±V <sub>REF</sub> at +V <sub>REF</sub>	Ext	0.024	12	71	2.3	SOIC-8, VSSOP-8	\$1.95
ADS7816	12	200	1 PDiff	Serial, SPI	V <sub>REF</sub>	Ext	0.024	12	72	1.9	PDIP/SOIC/VSSOP-8	\$1.95
TLV2545	12	200	1 PDiff	Serial, SPI	+5.5 (V <sub>REF</sub> = V <sub>DD</sub> )	Ext	0.024	12	72	2.8	SOIC-8, VSSOP-8	\$3.85
TLV2541	12	200	1 SE	Serial, SPI	V <sub>REF</sub>	Ext	0.024	12	72	2.8	SOIC-8, VSSOP-8	\$3.85
<b>ADS7866</b>	12	200	1 SE, 1 PDiff	Serial, SPI	V <sub>DD</sub> (1.2V to 3.6V)	Ext	0.024	12	70	0.25	SOT23-6	\$1.85
TLV2553	12	200	11 SE	Serial, SPI	V <sub>REF</sub>	Ext	0.024	12	—	2.43	SOIC-20, TSSOP-20	\$3.40
TLV2556	12	200	11 SE	Serial, SPI	V <sub>REF</sub>	Int/Ext	0.024	12	—	2.43	SOIC-20, TSSOP-20	\$3.55
TLV2542	12	200	2 SE	Serial, SPI	V <sub>REF</sub>	Ext	0.024	12	72	2.8	SOIC-8, VSSOP-8	\$3.85
ADS7842	12	200	4 SE	P12	V <sub>REF</sub>	Ext	0.024	12	72	0.84	SSOP-28	\$3.10
TLC2574	12	200	4 SE	Serial, SPI	±10	Ext	0.024	12	79	29	SOIC-20, TSSOP-20	\$5.30
TLV2544	12	200	4 SE	Serial, SPI	+2, 4	Int/Ext	0.024	12	70	3.3	SOIC-16, TSSOP-16	\$4.20
ADS7841	12	200	4 SE/2 Diff	Serial, SPI	V <sub>REF</sub> , ±V <sub>REF</sub> at V <sub>REF</sub>	Ext	0.024	12	72	0.84	SSOP-16	\$2.50
TLC2578	12	200	8 SE	Serial, SPI	±10	Ext	0.024	12	79	29	SOIC-24, TSSOP-24	\$5.80
TLV2548	12	200	8 SE	Serial, SPI	+2, 4	Int/Ext	0.024	12	70	3.3	SOIC-20, TSSOP-20	\$4.85
<b>AMC7823</b>	12	200	8 SE I/O DAS	Serial, SPI	V <sub>REF</sub> (5.0)	Int/Ext	0.024	12	74	100	QFN-40	\$9.75
ADS7844	12	200	8 SE/4 Diff	Serial, SPI	V <sub>REF</sub> , ±V <sub>REF</sub> at V <sub>REF</sub>	Ext	0.024	12	72	0.84	SSOP-20	\$2.90
ADS7822	12	200	1 PDiff	Serial, SPI	V <sub>REF</sub>	Ext	0.018	12	71	0.6	PDIP, SOIC, VSSOP-8	\$1.55
ADS7829	12	125	1 PDiff	Serial, SPI	V <sub>REF</sub>	Ext	0.018	12	71	0.6	QFN-8	\$1.50
ADS7804	12	100	1 SE	P8/P16	±10	Int/Ext	0.011	12	72	81.5	PDIP-28, SOIC-28	\$14.05
ADS7808	12	100	1 SE	Serial, SPI	+4, 10, ±3.3, 5, 10	Int/Ext	0.011	12	73	81.5	SOIC-20	\$10.85
AMC7820	12	100	8 SE DAS	Serial, SPI	V <sub>REF</sub> (5.0)	Int/Ext	0.024	12	72 (typ)	40	TQFP-48	\$3.75
TLC2543	12	66	11 SE	Serial, SPI	V <sub>REF</sub>	Ext	0.024	12	—	5	CDIP, PDIP, PLCC, SOIC, SSOP-20	\$4.45
TLV2543	12	66	11 SE	Serial, SPI	V <sub>REF</sub>	Ext	0.024	12	—	3.3	PDIP-20, SOIC-20, SSOP-20	\$4.45
ADS7823	12	50	1 SE	Serial, I2C	V <sub>REF</sub>	Ext	0.024	12	71	0.75	VSSOP-8	\$2.85
ADS7870	12	50	8 SE	Serial, SPI	PGA (1, 2, 4, 8, 10, 16, 20)	Int	0.06	12	72	4.6	SSOP-28	\$4.15
ADS7828	12	50	8 SE/4 Diff	Serial, I2C	V <sub>REF</sub>	Int/Ext	0.024	12	71	0.675	TSSOP-16	\$3.35
ADS7806	12	40	1 SE	Serial, SPI/P8	+4, 5, ±10	Int/Ext	0.011	12	73	28	PDIP-28, SOIC-28	\$12.75

\*Suggested resale price in U.S. dollars in quantities of 1,000.

New products are listed in bold red.



## SAR ADCs (Continued)

Device	Res. (Bits)	Sample Rate (kSPS)	Number of Input Channels	Interface	Input Voltage (V)	V <sub>REF</sub>	Linearity (%)	NMC	SINAD (dB)	Power (mW)	Package(s)	Price*
ADS7812	12	40	1 SE	Serial, SPI	+4, 10, ±3.3, 5, 10	Int/Ext	0.012	12	74	35	PDIP-16, SOIC-16	\$11.80
ADS7824	12	40	4 SE	Serial, SPI/P8	±10	Int/Ext	0.012	12	73	50	PDIP-28, SOIC-28	\$13.10
ADS1286	12	37	1 PDiff	Serial, SPI	V <sub>REF</sub>	Ext	0.024	12	72	1	PDIP-8, SOIC-8	\$2.80
TLV1571	10	1250	1 SE	Serial, SPI	V <sub>REF</sub>	Ext	0.1	10	60	12	SOIC-24, TSSOP-24	\$3.70
TLV1572	10	1250	1 SE	Serial, SPI	V <sub>REF</sub>	Ext	0.1	10	60	8.1	SOIC-8	\$3.30
TLV1570	10	1250	8 SE	Serial, SPI	2V, V <sub>REF</sub>	Int/Ext	0.1	10	60	9	SOIC-20, TSSOP-20	\$3.80
TLV1578	10	1250	8 SE	Serial, SPI	V <sub>REF</sub>	Ext	0.1	10	60	12	TSSOP-32	\$3.85
<b>ADS7887</b>	10	1250	1 SE, 1 PDiff	Serial, SPI	V <sub>DD</sub> (2.35V to 5.25V)	Ext (V <sub>DD</sub> )	0.073	10	61	8	SOT23-6, SC-70	\$1.50
TLC1514	10	400	4 SE/3 Diff	Serial, SPI	+5.5 (V <sub>REF</sub> = V <sub>DD</sub> )	Int/Ext	0.012	10	60	10	SOIC-16, TSSOP-16	\$2.90
TLC1518	10	400	8 SE/7 Diff	Serial, SPI	+5.5 (V <sub>REF</sub> = V <sub>DD</sub> )	Int/Ext	0.012	10	60	10	SOIC-20, TSSOP-20	\$3.45
<b>ADS7826</b>	10	200	1 PDiff	Serial, SPI	V <sub>REF</sub>	Ext	0.0048	10	62	0.6	QFN-8	\$1.25
<b>ADS7867</b>	10	200	1 SE, 1 PDiff	Serial, SPI	V <sub>DD</sub> (1.2V to 3.6V)	Ext	0.05	10	61	0.25	SOT23-6	\$1.40
TLV1504	10	200	4 SE	Serial, SPI	+2, 4	Int/Ext	0.05	10	60	3.3	SOIC-16, TSSOP-16	\$2.65
TLV1508	10	200	8 SE	Serial, SPI	+2, 4	Int/Ext	0.05	10	60	3.3	SOIC-20, TSSOP-20	\$3.15
TLC1550	10	164	1 SE	P10	V <sub>REF</sub>	Ext	0.05	10	—	10	PLCC-28, SOIC-24	\$3.90
TLC1551	10	164	1 SE	P10	V <sub>REF</sub>	Ext	0.1	10	—	10	PLCC-28, SOIC-24	\$3.35
TLV1544	10	85	4 SE	Serial, SPI	V <sub>REF</sub>	Ext	0.1	10	—	1.05	SOIC-16, TSSOP-16	\$1.95
TLV1548	10	85	8 SE	Serial, SPI	V <sub>REF</sub>	Ext	0.1	10	—	1.05	CDIP, LCCC, SSOP-20	\$2.30
TLC1549	10	38	1 SE	Serial, SPI	V <sub>REF</sub>	Ext	0.1	10	—	4	PDIP-8, SOIC-8	\$1.71
TLV1549	10	38	1 SE	Serial, SPI	V <sub>REF</sub>	Ext	0.1	10	—	1.32	PDIP-8, SOIC-8	\$1.85
TLC1542	10	38	11 SE	Serial, SPI	V <sub>REF</sub>	Ext	0.05	10	—	4	CDIP, LCCC, PDIP, PLCC, SOIC-20	\$2.50
TLC1543	10	38	11 SE	Serial, SPI	V <sub>REF</sub>	Ext	0.1	10	—	4	PLCC/SOIC/SSOP-20	\$1.90
TLV1543	10	38	11 SE	Serial, SPI	V <sub>REF</sub>	Ext	0.1	10	—	2.64	CDIP, LCCC, PDIP, PLCC, SOIC, SSOP-20	\$2.15
TLC1541	10	32	11 SE	Serial, SPI	V <sub>REF</sub>	Ext	0.1	10	—	6	PDIP/PLCC/SOIC-20	\$3.20
TLV571	8	1250	1 SE	P8	V <sub>REF</sub>	Ext	0.5	8	49	12	SOIC-24, TSSOP-24	\$2.35
<b>ADS7888</b>	8	1250	1 SE, 1 PDiff	Serial, SPI	V <sub>DD</sub> (2.35V to 5.25V)	Ext (V <sub>DD</sub> )	0.2	8	49.5	8	SOT23-6, SC-70	\$0.85
TLC0820A	8	392	1 SE	P8	V <sub>REF</sub>	Ext	0.2	8	—	37.5	PLCC/SOIC/SSOP-20	\$1.90
<b>ADS7827</b>	8	250	1 PDiff	Serial, SPI	V <sub>REF</sub>	Ext	0.2	8	48	0.6	QFN-8	\$1.00
<b>ADS7868</b>	8	200	1 SE, 1 PDiff	Serial, SPI	V <sub>DD</sub> (1.2V to 3.6V)	Ext	0.1	8	50	0.25	SOT23-6	\$0.80
TLC545	8	76	19 SE	Serial, SPI	V <sub>REF</sub>	Ext	0.2	8	—	6	PDIP-28, PLCC-28	\$3.10
ADS7830	8	75	8 SE/4 Diff	Serial, I <sup>2</sup> C	V <sub>REF</sub>	Int/Ext	0.19	8	50	0.675	TSSOP-16	\$1.40
TLV0831	8	49	1 SE	Serial, SPI	+3.6 (V <sub>REF</sub> = V <sub>DD</sub> )	Ext	0.2	8	—	0.66	PDIP-8, SOIC-8	\$1.40
TLC548	8	45.5	1 SE	Serial, SPI	V <sub>REF</sub>	Ext	0.2	8	—	9	PDIP-8, SOIC-8	\$1.20
TLV0832	8	44.7	2 SE/1 Diff	Serial, SPI	V <sub>REF</sub>	Ext	0.2	8	—	5	PDIP-8, SOIC-8	\$1.40
TLV0834	8	41	4 SE/2 Diff	Serial, SPI	V <sub>REF</sub>	Ext	0.2	8	—	0.66	PDIP/SOIC/TSSOP-14	\$1.45
TLC549	8	40	1 SE	Serial, SPI	V <sub>REF</sub>	Ext	0.2	8	—	9	PDIP-8, SOIC-8	\$0.95
TLC541	8	40	11 SE	Serial, SPI	V <sub>REF</sub>	Ext	0.2	8	—	6	PDIP, PLCC, SOIC-20	\$1.50
TLV0838	8	37.9	8 S/4 Diff	Serial, SPI	V <sub>REF</sub>	Ext	0.2	8	—	0.66	PDIP, SOIC, TSSOP-20	\$1.45
TLC0831	8	31	1 Diff	Serial, SPI	V <sub>REF</sub>	Ext	0.2	8	—	3	PDIP-8, SOIC-8	\$1.40
TLC542	8	25	11 SE	Serial, SPI	V <sub>REF</sub>	Ext	0.2	8	—	6	PDIP, PLCC, SOIC-20	\$1.50
TLC0832	8	22	2 SE/1 Diff	Serial, SPI	V <sub>REF</sub>	Ext	0.2	8	—	12.5	PDIP-8, SOIC-8	\$1.40
TLC0834	8	20	4 SE/2 Diff	Serial, SPI	V <sub>REF</sub>	Ext	0.2	8	—	3	PDIP-14, SOIC-14	\$1.45
TLC0838	8	20	8 SE/4 Diff	Serial, SPI	V <sub>REF</sub>	Ext	0.2	8	—	3	PDIP, SOIC, TSSOP-20	\$1.45

\*Suggested resale price in U.S. dollars in quantities of 1,000.

New products are listed in bold red.

## Pipeline ADCs



Analog-to-digital converters featuring sampling rates of 10s of MSPS are likely based on the pipeline architecture. The pipelined ADC consists of  $N$  cascaded stages. The concurrent operation of all pipeline stages makes this architecture suitable for achieving very high conversion rates. The stages themselves are essentially identical, lined up in an assembly line fashion and designed to convert only a portion of the analog sample. The digital output of each stage is combined to produce the parallel data output bits. A new digitized sample becomes available with every clock cycle. The internal combination process itself requires a digital delay, which is commonly referred to as the pipeline delay, or data latency. For most applications this is not a limitation since the delay, expressed in number of clock cycles, is a constant and can be accounted for.

One of the key architectural features of pipeline ADCs that allows high dynamic performances at high signal frequencies is the differential signal input. The differential input configuration results in the optimum dynamic range since it leads to smaller signal amplitude and a reduction in even-order harmonics. Almost all high-speed pipeline ADCs use a single-supply voltage, ranging from +5V down to +1.8V. Therefore, most require the analog input to operate with a common-mode voltage, which typically is at the mid-supply level. This common-mode or input bias requirement comes into consideration when defining the input interface circuitry that will drive the ADC. Switched capacitor inputs should also be considered.

### Technical Information

Pipeline ADCs also employ the basic idea of moving charge samples, which represent the input voltage level at the particular sample incident, from one stage to the next. The differential pipeline structure is highly repetitive where each of the pipeline stages consists of a sample-and-hold (S/H), a low-resolution ADC and DAC, and a summing circuit that includes an interstage amplifier to provide gain.

The analog signal is sampled with the first S/H circuit, which may also facilitate a single-ended to differential conversion. This S/H is one of the most critical blocks as it typically sets the performance limits of the converter. As the captured sample passes through the pipeline, the conversion is iterated by the stages that refine the conversion with increasing resolution as they pass the remainder signal from stage to stage. Each stage performs an analog-to-digital conversion, and a back-conversion to analog. The difference between the D/A output and the held input is the residue that is amplified and sent to the next stage where this process is repeated.

In order to properly design the interface circuit to the pipeline ADC, its switched-capacitor input structure needs to be considered. The input impedance of the pipeline converter represents a capacitive load to the driving source. Furthermore, it is dynamic since it is a function of the sampling rate ( $1/f_s$ ). The internal switches generate small transient current pulses that may affect the settling behavior of the source. To reduce the effects of this switched-capacitor, input series resistors and a shunt capacitor are typically recommended. This will also ensure stability and fast settling of the driving amplifier.

To select an appropriate interface circuit configuration, it is important to determine whether the application is time domain in nature (e.g. CCD-based imaging system) or a frequency domain application (e.g. communication system). Time domain applications usually have an input frequency bandwidth that includes DC. Frequency domain applications, on the other hand, are typically ac-coupled. The key converter specifications here are SFDR, SNR, aperture jitter and analog input bandwidth; the last two specifications particularly apply to undersampling applications. The optimum interface configuration will depend on whether the application calls for wide dynamic range (SFDR), or low noise (SNR), or both.

Critical to the performance of high-speed ADCs is the clock signal, since a variety of internal timing signals are derived from this clock. Pipeline ADCs may use both the rising and falling clock edge to trigger internal functions. For example, sampling occurs on the rising edge prompting this edge to have very low jitter. Clock jitter leads to aperture jitter, which can be the ultimate limitation in achieving good SNR performance. Particularly in undersampling applications, special consideration should be given to clock jitter.

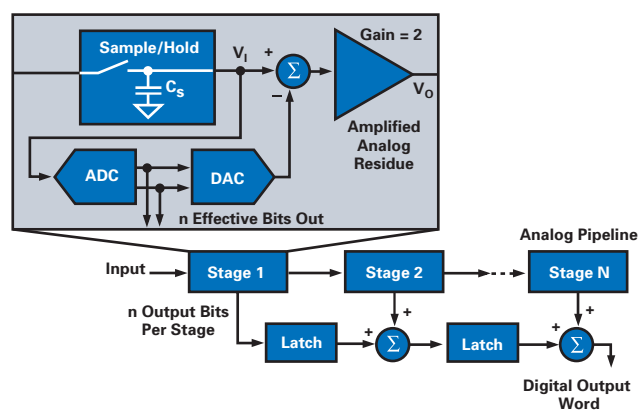

*Pipeline ADCs consist of consecutive stages, each containing a S/H, a low-resolution ADC and DAC, and a summing circuit that includes an interstage amplifier to provide gain.*

## → Pipeline ADCs

### 13-Bit, 210MSPS/250MSPS ADCs ADS5440, ADS5444

NEW

Get samples, datasheets, EVMs and app reports at: [www.ti.com/sc/device/ADS5440](http://www.ti.com/sc/device/ADS5440) and [www.ti.com/sc/device/ADS5444](http://www.ti.com/sc/device/ADS5444)

#### Key Features

- SNR: 68.7dBc at 100MHz IF and 250MSPS
- SFDR: 78dBc at 230MHz IF and 250MSPS
- Differential input voltage: 2.2Vpp
- Fully buffered analog inputs
- Total power dissipation: 2.1W
- 2's complement output format
- 3.3V LVDS-compatible outputs
- Packaging: TQFP-80 PowerPAD™

#### Applications

- Test and measurement
- Software-defined radio
- Multi-channel basestation receivers
- Basestation TX digital predistortion
- Communications instrumentation

The ADS5440 and ADS5444 are 13-bit, 210MSPS and 250MSPS, respectively, ADCs that operate from a single 5V supply and provide LVDS-compatible digital outputs from a 3.3V supply. Both offer outstanding SNR performance (68.7dBc at 100MHz IF and 250MSPS, ADS5444), as well as low noise and linearity over input.

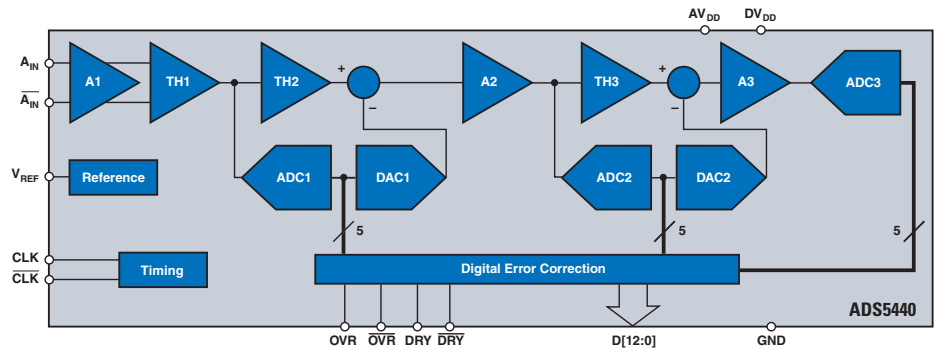

ADS5440 functional block diagram.

### 14-Bit, 80MSPS/105MSPS ADCs ADS5424, ADS5423, ADS5433

NEW

Get datasheets and app reports at: [www.ti.com/sc/device/ADS5424](http://www.ti.com/sc/device/ADS5424) and [www.ti.com/sc/device/ADS5423](http://www.ti.com/sc/device/ADS5423) and [www.ti.com/sc/device/ADS5433](http://www.ti.com/sc/device/ADS5433)

#### Key Features

- Resolution: 14-bit
- Sample rate: 80/105MSPS
- High SNR: 74.4 dBc (typ) at 30MHz IF (ADS5433)
- High SFDR: 96.5dBc (typ) at 30MHz IF (ADS5433)
- Differential input range: 2.2Vpp
- Supply operation: 5V
- 3.3V CMOS-compatible outputs
- Total power dissipation: 1.85W
- 2's complement output format
- On-chip input analog buffer, track and hold, and reference circuit
- Pin compatible to AD6644/45
- Industrial temperature range: -40°C to +85°C
- Packaging: 52-lead HTQFP with exposed heatsink

#### Applications

- Single and multichannel digital receivers
- Basestation infrastructure
- Instrumentation
- Video and imaging

The ADS5433 is a new member of the high performance wideband bipolar analog-to-digital converter family from TI; which includes the ADS5423 (14-bit, 80MSPS) and ADS5424 (14-bit, 105MSPS). The ADS5433 is a 14-bit, 80 MSPS ADC that's optimized for high SFDR performance up to 100 MHz input frequency; offering users up to 11dB better SFDR performance when compared to 14-bit and 16-bit ADCs with similar sample rates. This increased SFDR performance allows for increased receiver sensitivity and better adjacent channel rejection in wireless receiver designs.

With high SFDR performance, the ADS5433 provides a convenient upgrade path to many of the footprint-compatible sockets already in existence today and can extend performance of existing platforms or provide new levels of performance in systems that require high SFDR.

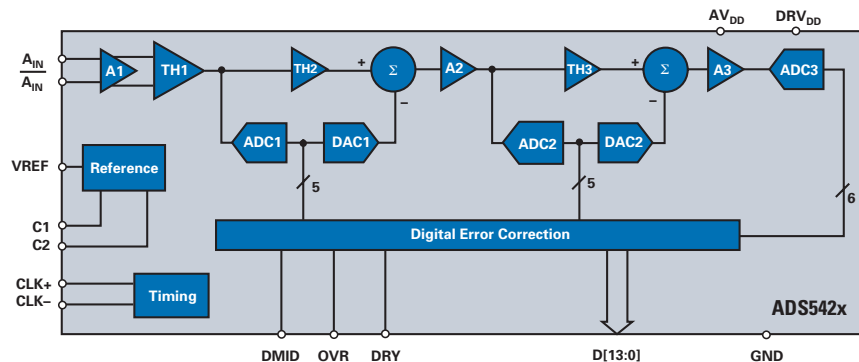

ADS542x family functional block diagram.



PREVIEW\*

14-Bit, 170MSPS/190MSPS ADCs with LVDS/CMOS Outputs

ADS5545, ADS5546

Get datasheets at: [www.ti.com/sc/device/ADS5545](http://www.ti.com/sc/device/ADS5545) and [www.ti.com/ADS5546](http://www.ti.com/ADS5546)

Key Features

- SNR: 73.2dBc at 70MHz IF
- SFDR: 84dBc at 70MHz IF
- Total power dissipation: 1W
- DDR LVDS and parallel CMOS output options
- Internal/external reference support
- Clock duty cycle stabilizer
- Power saving modes at lower sample rates
- 3.3V analog and digital supply
- Packaging: QFN-48 (7x7mm)

Applications

- Wireless communication infrastructure
- Software-defined radio
- Power amplifier linearization
- Test and measurement
- Medical imaging
- Radar systems

The ADS5545 and ADS5546 are 14-bit, 170MSPS and 190MSPS, respectively, ADCs that operate from a 3.3V supply and offer unprecedented digital output flexibility with fully differential double data rate (DDR) LVDS or parallel CMOS output options. Using an internal sample and hold and low jitter clock buffer, both devices support high SNR, high SFDR and high IF.

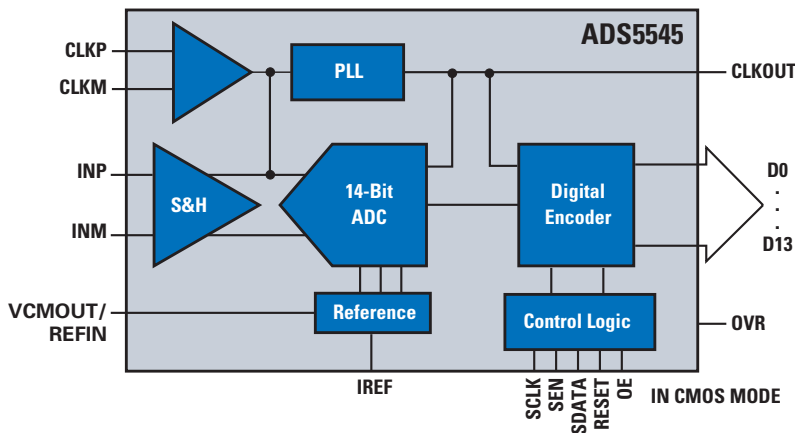

ADS5545 functional block diagram.

\*Expected ADS5545 release date, 3Q 2006

# ADC Capture Card

Texas Instruments' new ADC Capture Card (TSW1100), allows for high-speed digital data capture from TI's high-speed, high-resolution analog-to-digital converters (ADCs). It comes complete with software, allowing the user to quickly evaluate TI's ADCs without the need for expensive logic analyzers and complex analysis routines.

- 1MB capture depth at 140MSPS
- Single channel or synchronous dual-channel operation/evaluation
- Operation off a single wall mount 12V DC power supply
- USB interface to PC
- Software that computes ADC performance

[www.ti.com/tools](http://www.ti.com/tools)

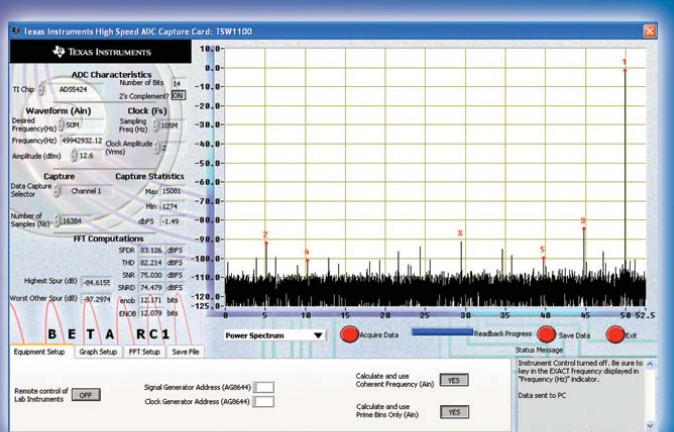





## Pipeline ADCs

### Pipeline ADCs Selection Guide

Device	Res. (Bits)	Sample Rate (MSPS)	# of Input Channels	Input Voltage (V)	Analog Input Bandwidth (MHz)	DNL (±LSB)	INL (±LSB)	SNR (dB)	SFDR (dB)	Supply Voltage (V)	Power (mW)	Package(s)	Price*
<b>ADS5546</b>	14	190	1 Diff	2	500	0.5	3	73.2	84	3, 3.6	1130	QFN-48	\$72.50
<b>ADS5545</b>	14	170	1 Diff	2	500	0.5	3	73.5	85	3, 3.6	1100	QFN-48	\$62.50
ADS5500	14	125	1 Diff	2	750	1.1	5	70.5	82	3, 3.6	780	HTQFP-64	\$95.00
ADS5424	14	105	1 Diff	2.2	570	-0.95, 1.5	1.5	74	93	4.75, 5.25	1900	HTQFP-52	\$56.00
ADS5541	14	105	1 Diff	2	750	-0.9, 1.1	5	72	85.1	3.0, 3.6	739	HTQFP-64	\$75.00
ADS5542	14	80	1 Diff	2	750	-0.9, 1.1	5	72.9	88	3.0, 3.6	674	HTQFP-64	\$25.55
ADS5423	14	80	1 Diff	2.2	570	-0.95, 1.5	1.5	74	94	4.75, 5.25	1850	HTQFP-52	\$40.00
<b>ADS5433</b>	14	80	1 Diff	2.2	570	-0.95, 1.5	1.5	74	97.2	4.75, 5.25	1850	HTQFP-52	\$48.00
ADS5553	14	65	2 Diff	2.3	750	1	4	74	84	3.0, 3.6	890	HTQFP-80	\$30.00
ADS5422	14	62	1 Diff	2 to 4	300	1	—	72	85	4.75, 5.25	1200	LQFP-64	\$30.45
ADS5421	14	40	1 Diff	2 to 4	300	1	—	75	83	4.75, 5.25	900	LQFP-64	\$20.15
ADS850	14	10	1 SE/1 Diff	2 to 4	300	1	5	76	85	4.7, 5.3	250	TQFP-48	\$16.80
THS1408	14	8	1 SE/1 Diff	1.5	140	1	5	72	80	3, 3.6	270	HTQFP-48, TQFP-48	\$14.85
THS1403	14	3	1 SE/1 Diff	1.5	140	1	5	72	80	3, 3.6	270	HTQFP-48, TQFP-48	\$11.05
THS14F03	14	3	1 SE/1 Diff	1.5	140	1	2.5	72	80	3, 3.6	270	TQFP-48	\$12.60
THS1401	14	1	1 SE/1 Diff	1.5	140	1	5	72	80	3, 3.6	270	HTQFP-48, TQFP-48	\$8.90
THS14F01	14	1	1 SE/1 Diff	1.5	140	1	2.5	72	80	3, 3.6	270	TQFP-48	\$9.65
<b>ADS5444</b>	13	250	1 SE/1 Diff	2.2	800	—	—	68.7	73	4.75, 5.25	2100	HTQFP-80	\$59.00
<b>ADS5440</b>	13	210	1 SE/1 Diff	2.2	800	1	2.2	69	80	4.75, 5.25	2100	HTQFP-80	\$42.00
ADS5520	12	125	1 Diff	2	750	0.5	1.5	69.7	83.6	3.0, 3.6	780	HTQFP-64	\$33.90
ADS5521	12	105	1 Diff	2	750	0.5	1.5	70	86	3.0, 3.6	736	HTQFP-64	\$29.90
ADS5522	12	80	1 Diff	2	750	0.5	1.5	69.7	82.8	3.0, 3.6	663	HTQFP-64	\$16.70
ADS5410	12	80	1 SE/1 Diff	2	1000	1	2	65	76	3, 3.6	360	TQFP-48	\$19.00
ADS809	12	80	1 SE/1 Diff	1 to 2	1000	1.7	6	63	67	4.75, 5.25	905	TQFP-48	\$24.95
ADS808	12	70	1 SE/1 Diff	1 to 2	1000	1.7	7	64	68	4.75, 5.25	720	TQFP-48	\$19.50
<b>ADS5273</b>	12	70	8 Diff	1.5	300	0.99, 1.2	3	71	85	3, 3.6	1003	HTQFP-80	\$121.00
ADS5413	12	65	1 Diff	2	1000	1	2	68.5	79	3.0, 3.6	400	HTQFP-48	\$15.50
ADS5221	12	65	1 SE/1 Diff	1 to 2	300	1	1.5	70	88	3.0, 3.6	285	TQFP-48	\$13.95
<b>ADS5232</b>	12	65	2 Diff	2	300	0.9	2	70.7	86	3, 3.6	340	TQFP-64	\$16.00
<b>ADS5242</b>	12	65	4 Diff	1.5	300	0.95, 1	2	71	85	3.0, 3.6	660	HTQFP-64	\$30.00
<b>ADS5272</b>	12	65	8 Diff	1.5	300	0.95, 1	2	71.1	85	3, 3.6	984	HTQFP-80	\$54.85
ADS807	12	53	1 SE/1 Diff	2 to 3	270	1	4	69	82	4.75, 5.25	335	SSOP-28	\$11.30
ADS2807	12	50	2 SE/2 Diff	2 to 3	270	1	5	65	70	4.75, 5.25	720	TQFP-64	\$18.05
ADS5271	12	50	8 Diff	1.5	300	0.9	2	70.5	85	3.0, 3.6	927	HTQFP-80	\$48.00
ADS5220	12	40	1 SE/1 Diff	1 to 2	300	1	1.5	70	88	3.0, 3.6	195	TQFP-48	\$9.85
ADS800	12	40	1 SE/1 Diff	2	65	1	—	62	61	4.75, 5.25	390	SO-28, TSSOP-28	\$30.85
ADS5240	12	40	4 Diff	1.5	300	0.9	2	70.5	85	3.0, 3.6	607	HTQFP-64	\$20.00
ADS5270	12	40	8 Diff	1.5	300	0.9	2	70.5	85	3.0, 3.6	888	HTQFP-80	\$44.00
ADS2806	12	32	2 SE/2 Diff	2 to 3	270	1	4	66	73	4.75, 5.25	430	TQFP-64	\$14.10
THS1230	12	30	1 SE/1 Diff	1 to 2	180	1	2.5	67.7	74.6	3, 3.6	168	SOIC-28, TSSOP-28	\$10.50
ADS801	12	25	1 SE/1 Diff	1 to 2	65	1	—	64	61	4.75, 5.25	270	SO-28, SSOP-28	\$12.55
ADS805	12	20	1 SE/1 Diff	2	270	0.75	2	68	74	4.75, 5.25	300	SSOP-28	\$9.90
THS1215	12	15	1 SE/1 Diff	1 to 2	180	0.9	1.5	68.9	81.7	3, 3.6	148	SOIC-28, SSOP-28	\$9.85
ADS802	12	10	1 SE/1 Diff	2	65	1	2.75	66	66	4.75, 5.25	260	SO-28, SSOP-28	\$12.60
ADS804	12	10	1 SE/1 Diff	2	270	0.75	2	69	80	4.7, 5.3	180	SSOP-28	\$9.20
THS12082	12	8	2 SE/1 Diff	2.5	96	1	1.5	69	71	4.75, 5.25	186	TSSOP-32	\$8.40
THS1209	12	8	2 SE/1 Diff	2.5	98	1	1.5	69	71	4.75, 5.25	186	TSSOP-32	\$7.90
THS1206	12	6	4 SE/2 Diff	2.5	96	1	1.8	69	71	4.75, 5.25	186	TSSOP-32	\$7.80
THS1207	12	6	4 SE/2 Diff	2.5	96	1	1.5	69	71	4.75, 5.25	186	TSSOP-32	\$7.25

\*Suggested resale price in U.S. dollars in quantities of 1,000.

New products are listed in bold red. Preview products are listed in bold blue.



## Pipeline ADCs Selection Guide (Continued)

Device	Res. (Bits)	Sample Rate (MSPS)	# of Input Channels	Input Voltage (V)	Analog Input Bandwidth (MHz)	DNL ( $\pm$ LSB)	INL ( $\pm$ LSB)	SNR (dB)	SFDR (dB)	Supply Voltage (V)	Power (mW)	Package(s)	Price*
ADS803	12	5	1 SE/1 Diff	2	270	2	0.75	69	82	4.7, 5.3	115	SSOP-28	\$7.40
ADS5413-11	11	65	1 Diff	2	1000	0.75	1	65	77	3, 3.6	400	HTQFP-48	\$14.75
ADS828	10	75	1 SE/1 Diff	2	300	1	3	57	68	4.75, 5.25	340	SSOP-28	\$8.70
ADS5102	10	65	1 Diff	1	950	1	2.5	57	71	1.65, 2	160	TQFP-48	\$7.10
<b>ADS5277</b>	10	65	8 Diff	1.5	300	0.5	1	61.7	85	3, 3.6	911	HTQFP-80	\$32.00
ADS5122	10	65	8 Diff	1	22	1	2.5	59	72	1.65, 2.0	733	BGA-257	\$42.85
ADS823	10	60	1 SE/1 Diff	2	300	1	2	60	74	4.75, 5.25	295	SSOP-28	\$8.40
ADS826	10	60	1 SE/1 Diff	2	300	1	2	59	73	4.75, 5.25	295	SSOP-28	\$8.40
ADS5103	10	40	1 Diff	1	950	0.8	1.5	58	66	1.65, 2	105	TQFP-48	\$5.25
ADS821	10	40	1 SE/1 Diff	2	65	1	2	58	62	4.75, 5.25	390	SSOP-28, SO-28	\$13.05
ADS822	10	40	1 SE/1 Diff	2	300	1	2	60	66	4.75, 5.25	200	SSOP-28	\$5.25
ADS825	10	40	1 SE/1 Diff	2	300	1	2	60	65	4.75, 5.25	200	SSOP-28	\$5.25
THS1040	10	40	1 SE/1 Diff	2	900	0.9	1.5	57	70	3, 3.6	100	SOIC-28, TSSOP-28	\$5.10
THS1041	10	40	1 SE/1 Diff	2	900	1	1.5	57	70	3, 3.6	103	SOIC-28, TSSOP-28	\$5.45
ADS5203	10	40	2 SE/2 Diff	1	300	1	1.5	60.5	73	3, 3.6	240	TQFP-48	\$9.65
ADS5204	10	40	2 SE/2 Diff	2	300	1	1.5	60.5	73	3, 3.6	275	TQFP-48	\$11.05
ADS5120	10	40	8 Diff	1	300	1	1.5	58	72	1.65, 2	794	BGA-257	\$36.15
ADS5121	10	40	8 Diff	1	28	1	1.5	60	74	1.65, 2.0	500	BGA-257	\$38.85
THS1030	10	30	1 SE/1 Diff	2	150	1	2	49.4	53	3, 5.5	150	SOIC-28, TSSOP-28	\$3.75
THS1031	10	30	1 SE/1 Diff	2	150	1	2	49.3	52.4	3, 5.5	160	SOIC-28, TSSOP-28	\$4.10
ADS820	10	20	1 SE/1 Diff	2	65	1	2	60	62	4.75, 5.25	200	SSOP-28, SO-28	\$6.75
ADS900	10	20	1 SE/1 Diff	1 to 2	100	1	—	49	53	2.7, 3.7	54	SSOP-28	\$3.55
ADS901	10	20	1 SE/1 Diff	1 to 2	100	1	—	53	49	2.7, 3.7	49	SSOP-28	\$3.40
THS10082	10	8	2 SE/1 Diff	2.5	96	1	1	61	65	4.75, 5.25	186	TSSOP-32	\$3.70
THS1009	10	8	2 SE/1 Diff	+1.5, +3.5	96	1	1	61	65	4.75, 5.25	186	TSSOP-32	\$3.20
THS10064	10	6	4 SE/2 Diff	2.5	96	1	1	61	65	4.75, 5.25	186	TSSOP-32	\$4.15
THS1007	10	6	4 SE/2 Diff	+1.5, +3.5	96	1	1	61	65	4.75, 5.25	186	TSSOP-32	\$3.70
TLV1562	10	2	4 SE/2 Diff	3	120	1.5	1.5	58	70.3	2.7, 5.5	15	SOIC-28, TSSOP-28	\$4.15
ADS831	8	80	1 SE/1 Diff	1 or 2	300	1	2	49	65	4.75, 5.25	310	SSOP-20	\$3.15
ADS830	8	60	1 SE/1 Diff	1 or 2	300	1	1.5	49.5	65	4.75, 5.25	215	SSOP-20	\$2.75
TLC5540	8	40	1 SE	2	75	1	1	44	42	4.75, 5.25	85	SOP-24, TSSOP-24	\$2.40
THS0842	8	40	2 SE/2 Diff	1.3	600	2	2.2	42.7	52	3, 3.6	320	TQFP-48	\$5.05
TLV5535	8	35	1 SE	1 to 1.6	600	1.3	2.4	46.5	58	3, 3.6	106	TSSOP-28	\$2.40
ADS931	8	30	1 SE	1 to 4	100	1	2.5	48	49	2.7, 5.5	154	SSOP-28	\$2.20
ADS930	8	30	1 SE/1 Diff	1	100	1	2.5	46	50	2.7, 5.25	168	SSOP-28	\$2.30
TLC5510	8	20	1 SE	2	14	0.75	1	46	42	4.75, 5.25	127.5	SOP-24	\$2.35
TLC5510A	8	20	1 SE	2	14	0.75	1	46	42	4.75, 5.25	150	SOP-24	\$2.35

\*Suggested resale price in U.S. dollars in quantities of 1,000.

New products are listed in bold red.

## → Delta-Sigma ( $\Delta\Sigma$ ) DACs

Delta-sigma ( $\Delta\Sigma$ ) DACs are the converse of delta-sigma ADCs with a digital modulator and analog filter.  $\Delta\Sigma$  DACs include a serial interface, control registers, modulator, switched capacitor

filter and a clock for the modulator and filter.  $\Delta\Sigma$  DACs have high resolution and low power making them ideal for closed-loop control in industrial control applications, high-resolution test and measurement

equipment, remote applications, battery-powered instruments and isolated systems.

### $\Delta\Sigma$ DACs Selection Guide

Device	Res. (Bits)	Settling Time (ms)	Number of Output DACs	Interface	Output (V)	$V_{REF}$	Linearity (%)	Monotonicity (Bits)	Power (mW)	Package	Price*
DAC1220	20	10	1	Serial, SPI	5	Ext	0.0015	20	2.5	SSOP-16	\$6.33
DAC1221	16	2	1	Serial, SPI	2.5	Ext	0.0015	16	1.2	SSOP-16	\$5.01

\*Suggested resale price in U.S. dollars in quantities of 1,000.

## → High-Precision and General Purpose DACs

Resistor "String" and R-2R DACs consist of four major elements: logic circuitry; some type of resistor network means of switching either a reference voltage or current to the proper input terminals of the network as a function of the digital value of each digital input bit, and a reference voltage.

### Technical Information

**R-2R DACs**—are used to achieve the best integral linearity performance. In an R-2R DAC, a current is generated by a reference voltage, which flows through the R-2R resistor network based on the digital input, which divides the current by two at each R-2R node. The advantage of a R-2R type

DAC is that it relies on the matching of the R and 2R resistor segments and not the absolute value of the resistors thus allowing trim techniques to be used to adjust the integral linearity and differential linearity.

**Voltage Segment DACs (String DACs)**—are simply a string of resistors, each of value R. The code loaded into the DAC register determines at which node on the string the voltage is tapped off to be fed into the output amplifier by closing one of the switches connecting the string to the amplifier. The DAC is monotonic, because it is a string of resistors. In higher resolution 12- and 16-bit DACs, two resistor strings are used to minimize the number of switches in

the design. In a two-resistor string configuration, the most significant bits drive a decoder tree, which selects the voltages from two adjacent taps of the first resistor string and applies them to the inputs of two buffers. These buffers then force these voltages across the endpoints of the second resistor string. The least significant data bits drive a second decoder tree, which selects the voltage at one of the switch outputs and directs it to the output buffer.

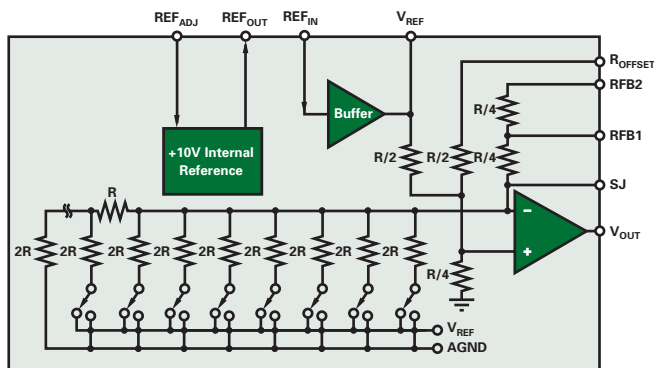

Segmented R-2R DAC.

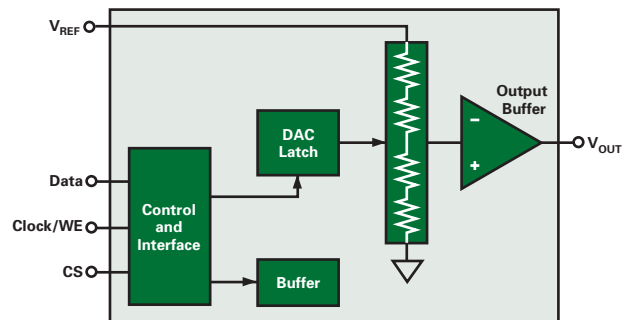

Voltage segment DAC.

## High-Precision and General-Purpose DACs



### 16-Bit, Ultra-Low Power, Voltage-Output DACs

#### DAC8830, DAC8831

Get samples, datasheets and app reports at: [www.ti.com/sc/device/DAC8830](http://www.ti.com/sc/device/DAC8830) and [www.ti.com/sc/device/DAC8831](http://www.ti.com/sc/device/DAC8831)

#### Key Features

- 16-bit resolution
- Single-supply operation: 2.7V to 5.5V
- Very low power: 15 $\mu$ W for 3V power
- High accuracy INL: 1LSB (max)
- Low glitch: 8nVs
- Low noise: 10nV/ $\sqrt{\text{Hz}}$
- Fast settling: 1.0 $\mu$ s
- Fast SPI interface, up to 50MHz
- Reset to zero-code
- Schmitt-trigger inputs for direct optocoupler interface
- Packaging:  
8-pin TI "D" (DAC8830)  
14-pin TI "D" (DAC8831)

#### Applications

- Portable equipment
- Automatic test equipment
- Industrial process control
- Data acquisition systems
- Optical networking

The DAC8830 and DAC8831 are single, 16-bit, serial-input, voltage-output DACs operating from a single 3V to 5V power supply. These converters provide excellent linearity (1LSB INL), low glitch, low noise, and fast settling time (1.0 $\mu$ s to 1/2 LSB of full-scale output) over the specified temperature range of  $-40^{\circ}\text{C}$  to  $+85^{\circ}\text{C}$ . The output is unbuffered, which reduces the power consumption and the error introduced by the output buffer amplifier.

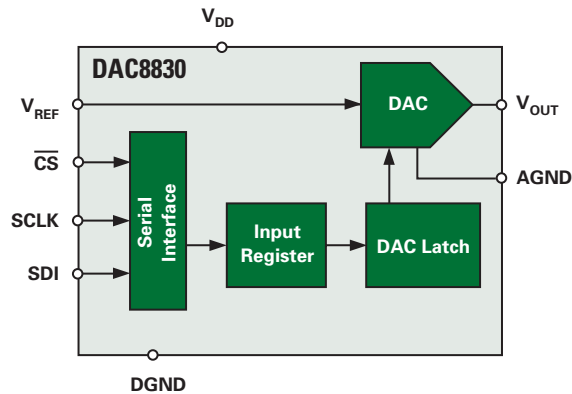

DAC8830 functional block diagram.

### 16-Bit, Ultra-Low Power, $\pm 10\text{V}$ Output DAC

#### DAC8871



Get datasheets at: [www.ti.com/sc/device/DAC8871](http://www.ti.com/sc/device/DAC8871)

#### Key Features

- Resolution: 16-bit
- Output voltage:  $\pm 10\text{V}$
- Low glitch: 2nV-s
- High accuracy INL: 1LSB
- Low noise: 12nV/ $\sqrt{\text{Hz}}$
- Settling time: 1 $\mu$ s to 1LSB
- Fast SPI interface
- Very low power
- Packaging: TSSOP-16

#### Applications

- Portable equipment
- ATE
- Industrial process control
- Data acquisition systems
- Optical networking

The DAC8871 is a single, serial-input, voltage-output DAC operating from a dual  $\pm 15\text{V}$  supply. The output is unbuffered, which reduces the power consumption and the error introduced by the output buffer amplifier. It features a standard high-speed 3V or 5V SPI serial interface with clock speeds up to 25MHz. For optimum performance, a set of Kelvin connections to the external reference is provided.

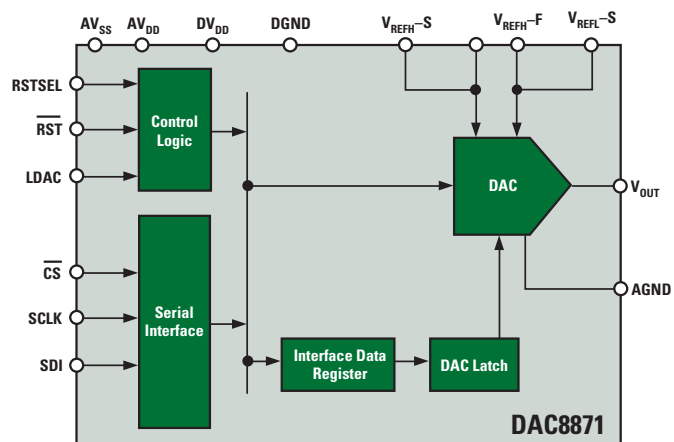

DAC8871 functional block diagram.

\*Expected DAC8871 release date, 3Q 06.

## → High-Precision and General-Purpose DACs

### 16-Bit, Quad-Channel, Ultra-Low Glitch, $V_{OUT}$ DACs DAC855x Family

Get samples, datasheets and EVMs at: [www.ti.com/sc/device/PARTnumber](http://www.ti.com/sc/device/PARTnumber) (Replace **PARTnumber** with **DAC8550, DAC8551, DAC8552, DAC8554** or **DAC8555**)

#### Key Features

- Relative accuracy: 12LSB (max)
- Glitch energy: 0.15nV-s
- Power supply: +2.7V to +5.5V
- microPower operation: 850 $\mu$ A at 5V
- Settling time: 10 $\mu$ s to  $\pm$ 0.003% FSR
- Ultra-low AC crosstalk: -100dB (typ)
- Power-on reset to zero-scale
- 16-Channel broadcast capability (DAC8554)
- Simultaneous or sequential output update and power-down
- Packaging: TSSOP-16

#### Applications

- Portable instrumentation
- Closed-loop servo control
- Process control
- Data acquisition systems
- Programmable attenuation
- PC peripherals

The DAC8554 is a 16-bit, quad-channel, voltage output DAC offering low-power operation and a flexible 3-wire serial interface capable of operating at clock frequencies up to 50MHz for  $IOV_{DD} = 5V$ . On-chip precision output amplifiers allow rail-to-rail swing over the supply range of 2.7V to 5.5V. A per channel power-down feature, accessed over the serial interface, reduces current consumption to 200nA per channel at 5V. Single, dual and quad versions are available.

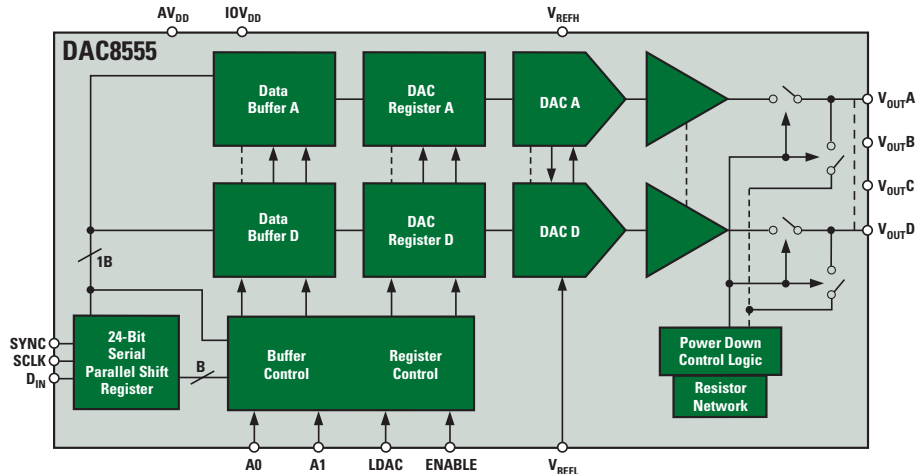

DAC8555 functional block diagram.

### 12-, 14- and 16-Bit, Serial-Input and Parallel-Input, Multiplying DAC Family DAC88xx Family, DAC78xx Family

NEW

Get samples, datasheets and EVMs at: [www.ti.com/sc/device/PARTnumber](http://www.ti.com/sc/device/PARTnumber) (Replace **PARTnumber** with **DAC8801, DAC8802, DAC8803, DAC8806, DAC8811, DAC8812, DAC8814, DAC8820, DAC7811** or **DAC7821**)

#### Key Features

- Relative accuracy: 1LSB (max)
- $\pm$ 2mA full-scale current with  $V_{REF} = \pm$ 10V
- Settling time: 0.5 $\mu$ s
- Midscale or zero-scale reset
- Four separate 4-quadrant ( $\pm$ 10V) multiplying reference inputs (DAC8814)
- Reference bandwidth: 10MHz
- Reference dynamics: -105dB THD
- Double-buffered registers enable
- Internal power-on reset
- Packaging: MSOP-8, SON-8, SSOP-28, TSSOP-16

#### Applications

- Automatic test equipment
- Instrumentation
- Digitally controlled calibration
- Industrial control PLCs

The DAC88xx and DAC78xx families of current output DACs are designed to operate from a single +2.7V to 5V supply and are available in single, dual and quad versions. A double-buffered serial data interface offers high-speed, 3-wire, SPI and microcontroller-compatible inputs using serial data in, clock and a chip-select. A parallel version is available.

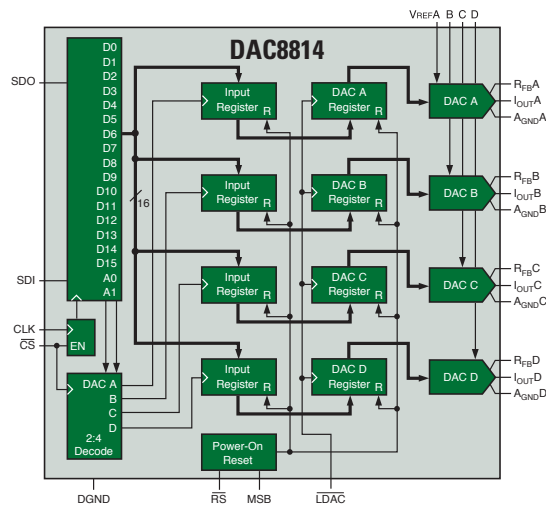

DAC8814 functional block diagram.



## High-Precision and General-Purpose DACs



### High-Precision and General-Purpose DACs Selection Guide

Device	Res. (Bits)	Settling Time ( $\mu$ s)	Number of Output DACs	Interface	Output (V)	$V_{REF}$	Linearity (%)	Monotonic (Bits)	Architecture	Power (mW) (typ)	Package(s)	Price*
<b>High-Precision, Low-Power DACs</b>												
<b>DAC8811</b>	16	0.5	1	Serial, SPI	$I_{OUT} (\pm 10V)$	Ext	0.0015	16	R-2R	0.025	MSOP-8, SON-8	\$8.50
<b>DAC8820</b>	16	0.5	1	P16	$I_{OUT} (\pm 10V)$	Ext	0.0015	16	R-2R	0.025	SSOP-28	\$8.50
<b>DAC8812</b>	16	0.5	2	Serial, SPI	$I_{OUT} (\pm 10V)$	Ext	0.0015	16	R-2R	0.025	TSSOP-16	\$8.40
<b>DAC8822</b>	16	0.5	2	P16	$I_{OUT} (\pm 10V)$	Ext	0.0015	16	R-2R	0.025	TSSOP-18	\$11.70
<b>DAC8830</b>	16	1	1	Serial, SPI	$+V_{REF}$	Ext	0.0015	16	R-2R	0.015	SOIC-8	\$7.95
<b>DAC8831</b>	16	1	1	Serial, SPI	$+V_{REF}$	Ext	0.0015	16	R-2R	0.015	SOIC-14	\$7.95
<b>DAC8814</b>	16	1	4	Serial, SPI	$I_{OUT} (\pm 10V)$	Ext	0.0015	16	R-2R	0.0275	SSOP-28	\$19.30
<b>DAC8881</b>	16	2	1	Serial, SPI	5	Ext	0.0015	16	R-2R	60	QFN-20	\$6.00
DAC7641	16	10	1	P16	$+V_{REF}, \pm V_{REF}$	Ext	0.0015	15	R-2R	1.8	TQFP-32	\$6.30
DAC7631	16	10	1	Serial, SPI	$+V_{REF}, \pm V_{REF}$	Ext	0.0015	15	R-2R	1.8	SSOP-20	\$5.85
DAC7642	16	10	2	P16	$+V_{REF}, \pm V_{REF}$	Ext	0.0015	15	R-2R	2.5	LQFP-32	\$10.55
DAC7643	16	10	2	P16	$+V_{REF}, \pm V_{REF}$	Ext	0.0015	15	R-2R	2.5	LQFP-32	\$10.55
DAC7632	16	10	2	Serial, SPI	$+V_{REF}, \pm V_{REF}$	Ext	0.0015	15	R-2R	2.5	LQFP-32	\$10.45
DAC7634	16	10	4	Serial, SPI	$+V_{REF}, \pm V_{REF}$	Ext	0.0015	15	R-2R	7.5	SSOP-48	\$19.95
DAC7644	16	10	4	P16	$+V_{REF}, \pm V_{REF}$	Ext	0.0015	15	R-2R	7.5	SSOP-48	\$19.95
DAC7654	16	12	4	Serial, SPI	$\pm 2.5$	Int	0.0015	16	R-2R	18	LQFP-64	\$21.80
DAC7664	16	12	4	P16	$\pm 2.5$	Int	0.0015	16	R-2R	18	LQFP-64	\$20.75
<b>DAC8801</b>	14	0.5	1	Serial, SPI	$I_{OUT} (\pm 10V)$	Ext	0.0061	14	R-2R	0.025	MSOP-8, SON-8	\$5.50
<b>DAC8802</b>	14	0.5	2	Serial, SPI	$I_{OUT} (\pm 10V)$	Ext	0.0061	14	R-2R	0.025	TSSOP-16	\$7.25
<b>DAC8803</b>	14	1	4	Serial, SPI	$I_{OUT} (\pm 10V)$	Ext	0.0061	14	R-2R	0.0275	SSOP-28	\$14.40
<b>DAC8806</b>	14	0.5	1	P16	$I_{OUT} (\pm 10V)$	Ext	0.0061	14	R-2R	0.025	SSOP-28	\$5.50
<b>DAC7811</b>	12	0.2	1	Serial, SPI	$I_{OUT} (\pm 10V)$	Ext	0.012	12	R-2R	0.05	MSOP-10, SON-8	\$3.15
<b>DAC7821</b>	12	0.2	1	P12	$I_{OUT} (\pm 10V)$	Ext	0.012	12	R-2R	0.05	MSOP-10, SON-8	\$3.15
<b>DAC7822</b>	12	0.2	2	P12	$I_{OUT} (\pm 10V)$	Ext	0.012	12	R-2R	0.05	MSOP-10, SON-8	\$4.75
DAC7611	12	7	1	Serial, SPI	4.096	Int	0.012	12	R-2R	2.5	PDIP-8, SOIC-8	\$2.55
DAC7621	12	7	1	P12	4.096	Int	0.012	12	R-2R	2.5	SSOP-20	\$2.75
DAC7612	12	7	2	Serial, SPI	4.096	Int	0.012	12	R-2R	3.75	SOIC-8	\$2.70
DAC7571	12	10	1	Serial, I <sup>2</sup> C	$+V_{REF}$	Ext	0.096	12	String	0.7	SOP-6, SOT23-6	\$1.55
DAC7613	12	10	1	P12	$+V_{REF}, \pm V_{REF}$	Ext	0.012	12	R-2R	1.8	SSOP-24	\$2.50
DAC7573	12	10	4	Serial, I <sup>2</sup> C	$+V_{REF}$	Ext	0.096	12	String	3	TSSOP-16	\$6.15
DAC7574	12	10	4	Serial, I <sup>2</sup> C	$+V_{REF}$	Ext	0.096	12	String	3	MSOP-10	\$6.15
DAC7614	12	10	4	Serial, SPI	$+V_{REF}, \pm V_{REF}$	Ext	0.012	12	R-2R	20	PDIP-16, SOIC-16, SSOP-20	\$6.70
DAC7615	12	10	4	Serial, SPI	$+V_{REF}, \pm V_{REF}$	Ext	0.012	12	R-2R	20	PDIP-16, SOIC-16, SSOP-20	\$6.70
DAC7616	12	10	4	Serial, SPI	$+V_{REF}, \pm V_{REF}$	Ext	0.012	12	R-2R	3	SOIC-16, SSOP-20	\$5.40
DAC7617	12	10	4	Serial, SPI	$+V_{REF}, \pm V_{REF}$	Ext	0.012	12	R-2R	3	SOIC-16, SSOP-20	\$5.40
DAC7624	12	10	4	P12	$+V_{REF}, \pm V_{REF}$	Ext	0.012	12	R-2R	20	PDIP-28, SOIC-28	\$10.25
DAC7625	12	10	4	P12	$+V_{REF}, \pm V_{REF}$	Ext	0.012	12	R-2R	20	PDIP-28, SOIC-28	\$10.25
<b>High-Precision, High-Voltage DACs</b>												
<b>DAC8871</b>	16	5	1	Serial, SPI	$\pm 10$	Ext	0.0015	16	R-2R	15	SOIC-14	\$7.25
DAC7731	16	5	1	Serial, SPI	$+10, \pm 10$	Int/Ext	0.0015	16	R-2R	100	SSOP-24	\$8.20
DAC7742	16	5	1	P16	$+10, \pm 10$	Int/Ext	0.0015	16	R-2R	100	LQFP-48	\$8.70
DAC7741	16	5	1	P16	$+10, \pm 10$	Int/Ext	0.0015	16	R-2R	100	LQFP-48	\$8.30
DAC712	16	10	1	P16	$\pm 10$	Int	0.003	15	R-2R	525	SOIC-28	\$14.50
DAC714	16	10	1	Serial, SPI	$\pm 10$	Int	0.0015	16	R-2R	525	SOIC-16	\$14.50
DAC715	16	10	1	P16	10	Int	0.003	16	R-2R	525	SOIC-28	\$15.85
DAC716	16	10	1	Serial, SPI	10	Int	0.003	16	R-2R	525	SOIC-16	\$15.85
DAC7734	16	10	4	Serial, SPI	$+V_{REF}, \pm V_{REF}$	Ext	0.0015	16	R-2R	50	SSOP-48	\$31.45
DAC7744	16	10	4	P16	$+V_{REF}, \pm V_{REF}$	Ext	0.0015	16	R-2R	50	SSOP-48	\$31.45
DAC811	12	4	1	P12	$+10, \pm 5, 10$	Int	0.006	12	R-2R	625	CDIP SB-28, PDIP-28	\$11.00
DAC813	12	4	1	P12	$+10, \pm 5, 10$	Int/Ext	0.006	12	R-2R	270	PDIP-28, SOIC-28	\$12.60
DAC7714	12	10	4	Serial, SPI	$+V_{REF}, \pm V_{REF}$	Ext	0.012	12	R-2R	45	SOIC-16	\$11.45

\*Suggested resale price in U.S. dollars in quantities of 1,000.

New products are listed in bold red. Preview products are listed in bold blue.

## → High-Precision and General-Purpose DACs

### High-Precision and General-Purpose DACs Selection Guide (Continued)

Device	Res. (Bits)	Settling Time (μs)	Number of Output DACs	Interface	Output (V)	V <sub>REF</sub>	Linearity (%)	Monotonic (Bits)	Architecture	Power (mW) (typ)	Package(s)	Price*
<b>High-Precision, High-Voltage DACs (Continued)</b>												
DAC7715	12	10	4	Serial, SPI	+V <sub>REF</sub> , ±V <sub>REF</sub>	Ext	0.012	12	R-2R	45	SOIC-16	\$11.45
DAC7724	12	10	4	P12	+V <sub>REF</sub> , ±V <sub>REF</sub>	Ext	0.012	12	R-2R	45	PLCC-28, SOIC-28	\$11.85
DAC7725	12	10	4	P12	+V <sub>REF</sub> , ±V <sub>REF</sub>	Ext	0.012	12	R-2R	45	PLCC-28, SOIC-28	\$11.85
<b>General-Purpose DACs</b>												
<b>DAC8580</b>	16	0.65	1	Serial, SPI	±V <sub>REF</sub>	Ext	0.096	16	String	175	TSSOP-16	\$3.00
<b>DAC8581</b>	16	0.65	1	Serial, SPI	±V <sub>REF</sub>	Ext	0.096	16	String	175	TSSOP-16	\$3.00
DAC8544	16	8	4	P16	+V <sub>REF</sub>	Ext	0.025	16	String	4.75	QFN 5 x 5	\$9.75
<b>DAC8550/51</b>	16	10	1	Serial, SPI	+V <sub>REF</sub>	Ext	0.012	16	String	1	VSSOP-8, QFN 3x3	\$2.95
DAC8501	16	10	1	Serial, SPI	V <sub>REF</sub> /MDAC	Ext	0.0987	16	String	0.72	VSSOP-8	\$3.00
DAC8531	16	10	1	Serial, SPI	+V <sub>REF</sub>	Ext	0.0987	16	String	0.72	VSSOP-8, QFN 3x3	\$3.00
DAC8541	16	10	1	P16	+V <sub>REF</sub>	Ext	0.096	16	String	0.72	TQFP-32	\$3.00
DAC8571	16	10	1	Serial, I2C	+V <sub>REF</sub>	Ext	0.0987	16	String	0.42	MSOP-8	\$2.95
<b>DAC8552</b>	16	10	2	Serial, SPI	+V <sub>REF</sub>	Ext	0.012	16	String	2	MSOP-8	\$6.25
DAC8532	16	10	2	Serial, SPI	+V <sub>REF</sub>	Ext	0.0987	16	String	1.35	VSSOP-8	\$5.35
<b>DAC8554</b>	16	10	4	Serial, SPI	+V <sub>REF</sub>	ext	0.0122	16	String	4	TSSOP-16	\$10.40
<b>DAC8555</b>	16	10	4	Serial, SPI	+V <sub>REF</sub>	ext	0.0122	16	String	4	TSSOP-16	\$10.40
DAC8534	16	10	4	Serial, SPI	+V <sub>REF</sub>	Ext	0.0987	16	String	2.7	TSSOP-16	\$8.75
DAC8574	16	10	4	Serial, I2C	+V <sub>REF</sub>	Ext	0.0987	16	String	2.7	TSSOP-16	\$10.25
DAC7800	12	0.8	2	Serial, SPI	1mA	Ext	0.012	12	R-2R	1	PDIP-16, SOIC-16	\$13.55
DAC7801	12	0.8	2	P12	1mA	Ext	0.012	12	R-2R	1	PDIP-24, SOIC-24	\$17.95
DAC7802	12	0.8	2	P12	1mA	Ext	0.012	12	R-2R	1	PDIP-24, SOIC-24	\$14.00
DAC7541	12	1	1	P12	±V <sub>REF</sub> /MDAC	Ext	0.012	12	R-2R	30	PDIP-18, SOP-18	\$6.70
DAC8043	12	1	1	Serial, SPI	±V <sub>REF</sub> /MDAC	Ext	0.012	12	R-2R	2.5	SOIC-8	\$5.25
TLV5613	12	1	1	P8	+V <sub>REF</sub>	Ext	0.1	12	String	1.2	SOIC-20, TSSOP-20	\$2.60
TLV5619	12	1	1	P12	+V <sub>REF</sub>	Ext	0.08	12	String	4.3	SOIC-20, TSSOP-20	\$2.60
TLV5633	12	1	1	P8	+2, 4	Int/Ext	0.08	12	String	2.7	SOIC-20, TSSOP-20	\$4.70
TLV5636	12	1	1	Serial, SPI	+2, 4	Int/Ext	0.1	12	String	4.5	SOIC-8, VSSOP-8	\$3.65
TLV5639	12	1	1	P12	+2, 4	Int/Ext	0.1	12	String	2.7	SOIC-20, TSSOP-20	\$3.45
TLV5638	12	1	2	Serial, SPI	+2, 4	Int/Ext	0.1	12	String	4.5	SOIC-8, CDIP-8, LCCC-20	\$3.25
TLV5610	12	1	8	Serial, SPI	+V <sub>REF</sub>	Ext	0.4	12	String	18	SOIC-20, TSSOP-20	\$8.50
TLV5630	12	1	8	Serial, SPI	+V <sub>REF</sub>	Int/Ext	0.4	12	String	18	SOIC-20, TSSOP-20	\$8.85
DAC7545	12	2	1	P12	±V <sub>REF</sub> /MDAC	Ext	0.012	12	R-2R	30	SOIC-20	\$5.25
TLV5618A	12	2.5	2	Serial, SPI	+V <sub>REF</sub>	Ext	0.08	12	String	1.8	CDIP-8, PDIP-8, SOIC-8, LCCC-20	\$4.75
TLV5616	12	3	1	Serial, SPI	+V <sub>REF</sub>	Ext	0.1	12	String	0.9	VSSOP-8, PDIP-8, SOIC-8	\$2.60
TLV5614	12	3	4	Serial, SPI	+V <sub>REF</sub>	Ext	0.1	12	String	3.6	SOIC-16, TSSOP-16	\$7.45
<b>DAC7551</b>	12	5	1	Serial, SPI	+V <sub>REF</sub>	Ext	0.012	12	String	0.27	SON-12	\$1.40
<b>DAC7552</b>	12	5	2	Serial, SPI	+V <sub>REF</sub>	Ext	0.024	12	String	0.675	QFN-16	\$2.35
<b>DAC7553</b>	12	5	2	Serial, SPI	+V <sub>REF</sub>	Ext	0.024	12	String	0.675	QFN-16	\$2.35
<b>DAC7554</b>	12	5	4	Serial, SPI	+V <sub>REF</sub>	Ext	0.024	12	String	1	MSOP-10	\$5.60
<b>DAC7558</b>	12	5	8	Serial, SPI	+V <sub>REF</sub>	Ext	0.012	12	String	2	QFN-32	\$10.40
DAC7512	12	10	1	Serial, SPI	V <sub>CC</sub>	Ext	0.38	12	String	0.7	VSSOP-8, SOT23-6	\$1.45
DAC7513	12	10	1	Serial, SPI	+V <sub>REF</sub>	Ext	0.38	12	String	0.5	VSSOP-8, SSOP-8	\$1.45
TLV5637	10	0.8	2	Serial, SPI	+2, 4	Int/Ext	0.1	10	String	4.2	SOIC-8	\$3.20
TLV5608	10	1	8	Serial, SPI	+V <sub>REF</sub>	Ext	0.4	10	String	18	SOIC-20, TSSOP-20	\$4.90
TLV5631	10	1	8	Serial, SPI	+V <sub>REF</sub>	Int/Ext	0.4	10	String	18	SOIC-20, TSSOP-20	\$5.60
TLV5617A	10	2.5	2	Serial, SPI	+V <sub>REF</sub>	Ext	0.1	10	String	1.8	SOIC-8	\$2.25
TLV5606	10	3	1	Serial, SPI	+V <sub>REF</sub>	Ext	0.15	10	String	0.9	SOIC-8, VSSOP-8	\$1.30
TLV5604	10	3	4	Serial, SPI	+V <sub>REF</sub>	Ext	0.05	10	String	3	SOIC-16, TSSOP-16	\$3.70
<b>DAC6571</b>	10	9	1	Serial, I2C	V <sub>DD</sub>	Ext	0.195	10	String	0.5	SOP-6	\$1.40

\*Suggested resale price in U.S. dollars in quantities of 1,000.

New products are listed in bold red.

## High-Precision and General-Purpose DACs



## High-Precision and General Purpose DACs Selection Guide (Continued)

Device	Res. (Bits)	Settling Time ( $\mu$ s)	Number of Output DACs	Interface	Output (V)	$V_{REF}$	Linearity (%)	Monotonic (Bits)	Architecture	Power (mW) (typ)	Package(s)	Price*
<b>High-Precision, High-Voltage DACs (Continued)</b>												
<b>DAC6573</b>	10	9	4	Serial, I <sup>2</sup> C	+ $V_{REF}$	Ext	0.195	10	String	1.5	TSSOP-16	\$3.05
<b>DAC6574</b>	10	9	4	Serial, I <sup>2</sup> C	+ $V_{REF}$	Ext	0.195	10	String	1.5	VSSOP-10	\$3.05
TLC5615	10	12.5	1	Serial, SPI	+ $V_{REF}$	Ext	0.1	10	String	0.75	PDIP-8, SOIC-8, VSSOP-8	\$1.90
TLC7524	8	0.1	1	P8	1mA	Ext	0.2	8	R-2R	5	PDIP-16, PLCC-20, SOIC-16, TSSOP-16	\$1.45
TLC7528	8	0.1	2	P8	1mA	Ext	0.2	8	R-2R	7.5	PDIP-20, PLCC-20, SOIC-20, TSSOP-20	\$1.55
TLC7628	8	0.1	2	P8	2mA	Ext	0.2	8	R-2R	20	SOIC-20, PDIP-20	\$1.45
TLV5626	8	0.8	2	Serial, SPI	+2, 4	Int/Ext	0.4	8	String	4.2	SOIC-8	\$1.90
TLV5624	8	1	1	Serial, SPI	+2, 4	Int/Ext	0.2	8	String	0.9	SOIC-8, VSSOP-8	\$1.60
TLV5629	8	1	8	Serial, SPI	Ext	Ext	0.4	8	String	18	SOIC-20, TSSOP-20	\$3.15
TLV5632	8	1	8	Serial, SPI	+2, 4	Int/Ext	0.4	8	String	18	SOIC-20, TSSOP-20	\$3.35
TLV5627	8	2.5	4	Serial, SPI	+ $V_{REF}$	Ext	0.2	8	String	3	SOIC-16, TSSOP-16	\$2.05
TLV5623	8	3	1	Serial, SPI	+ $V_{REF}$	Ext	0.2	8	String	2.1	SOIC-8, VSSOP-8	\$0.99
TLV5625	8	3	2	Serial, SPI	+ $V_{REF}$	Ext	0.2	8	String	2.4	SOIC-8	\$1.70
TLC7225	8	5	4	P8	+ $V_{REF}$	Ext	0.4	8	R-2R	75	SOIC-24	\$2.35
TLC7226	8	5	4	P8	$\pm V_{REF}$	Ext	0.4	8	R-2R	90	PDIP-20, SOIC-20	\$2.15
<b>DAC5571</b>	8	8	1	Serial, I <sup>2</sup> C	$V_{DD}$	Int	0.195	8	String	0.5	SOP-6	\$0.90
<b>DAC5573</b>	8	8	4	Serial, I <sup>2</sup> C	+ $V_{REF}$	Ext	0.195	8	String	1.5	TSSOP-16	\$2.55
<b>DAC5574</b>	8	8	4	Serial, I <sup>2</sup> C	+ $V_{REF}$	Ext	0.195	8	String	1.5	VSSOP-10	\$2.55
TLC5620	8	10	4	Serial, SPI	+ $V_{REF}$	Ext	0.4	8	String	8	PDIP-14, SOIC-14	\$1.50
TLV5620	8	10	4	Serial, SPI	+ $V_{REF}$	Ext	0.2	8	R-2R	6	PDIP-14, SOIC-14	\$1.00
TLV5621	8	10	4	Serial, SPI	+ $V_{REF}$	Ext	0.4	8	R-2R	3.6	SOIC-14	\$1.65
TLC5628	8	10	8	Serial, SPI	+ $V_{REF}$	Ext	0.4	8	String	15	PDIP-16, SOIC-16	\$2.45
TLV5628	8	10	8	Serial, SPI	+ $V_{REF}$	Ext	0.4	8	String	12	PDIP-16, SOIC-16	\$2.20

\*Suggested resale price in U.S. dollars in quantities of 1,000.

New products are listed in bold red.



## Current Steering DACs

Modern high-speed DACs, fabricated on submicron CMOS or BiCMOS processes, have reached new performance levels with update rates of 500MSPS and resolutions of 14- or even 16-bits. In order to realize such high update rates and resolutions, the DACs employ a current-steering architecture with segmented current sources. The core element within the monolithic DAC is the current source array designed to deliver the full-scale output current, typically 20mA. An internal decoder addresses the differential current switches each time the DAC is updated. Steering the currents from all current sources to either of the differential

outputs forms a corresponding signal output current. Differential signaling is used to improve the dynamic performance while reducing the output voltage swing that is developed across the load resistors. Ideally, this signal voltage amplitude should be as small as possible to maintain optimum linearity of the DAC. The upper limit of this signal voltage, and consequently the load resistance, is defined by the output voltage compliance specification.

The segmented current-steering architecture provides a significant reduction in circuit complexity and consequently in reduced glitch energy. This translates into an overall

improvement of the DAC's linearity and ac performance. As new system architectures require the synthesis of output frequencies in the 100s of MHz range, an approach often referred to as "direct IF" achieves high update rates, while maintaining excellent dynamic performance.

### 10-/12-/14-Bit, 200MSPS Dual DACs DAC5652, DAC5662, DAC5672

Get samples, datasheets, EVMs and app reports at: [www.ti.com/sc/device/PARTnumber](http://www.ti.com/sc/device/PARTnumber) (Replace **PARTnumber** with **DAC5652**, **DAC5662** or **DAC5672**)

#### Key Features

- Update rate: 275MSPS
- Single supply: 3.0V to 3.6V
- High SFDR: 85dBc at 5MHz
- High IMD<sub>3</sub>: 78dBc at 15.1 and 16.1MHz
- WCDMA A<sub>CLR</sub>: 70dB at 30.72MHz; 78dB at baseband
- Independent or single resistor gain control
- Dual or interleaved data
- On-chip 1.2V internal or external reference
- Low power: 330mW; powerdown: 15mW
- Packaging: 48-lead TQFP

#### Applications

- Cellular base transceiver station transmit channels:
  - CDMA: WCDMA, CDMA2000®, IS-95 standards
  - TDMA: GSM, IS-136, EDGE/ UWC-136 standards
- Medical/test instrumentation
- Arbitrary waveform generators (AWG)
- Direct digital synthesis (DDS)
- Cable modem termination systems (CMTS)

The DAC5652, DAC5662 and DAC5672 are dual-channel, 10-/12-/14-bit, high-speed DACs with an on-chip voltage reference. Operating with update rates of up to 200MSPS, the DAC5652, DAC5662 and DAC5672 offer exceptional dynamic performance and tight gain and offset matching, characteristics that make them suitable in either I/Q baseband or direct IF communications applications. The 10-/12-/14-bit family is pin-compatible, allowing easy resolution upgrades. DAC290x, which is pin-compatible with DAC56x2, can be used for 5V applications.

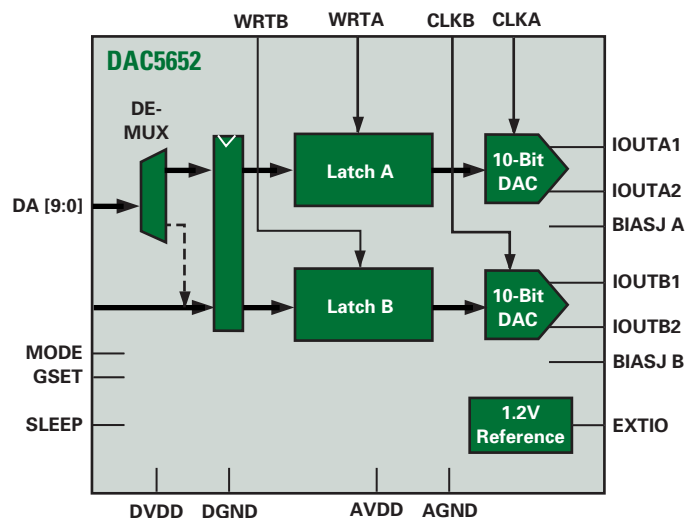

DAC5652 block diagram.



### Low-Noise, 16-Bit, 500MSPS Dual DAC DAC5687

Get samples, datasheets, EVMs and app reports at: [www.ti.com/sc/device/DAC5687](http://www.ti.com/sc/device/DAC5687)

#### Key Features

- Data rate: 500MSPS
- On-chip PLL/VCO clock multiplier
- Full I/Q compensation including offset, gain and phase
- Flexible input options:
  - FIFO with latch on external or internal clock
  - Even/odd multiplexed input
  - Single-port demultiplexed input
- 1.8V or 3.3V I/O voltage
- High performance
  - SNR = 75dBFS at 25MHz, 500MSPS
  - IMD<sub>3</sub> = 81dBc at 25MHz, 500MSPS
- Single supply: 3.3V

#### Applications

- Cellular base transceiver stations
- Transmit channels:
  - CDMA: WCDMA, CDMA2000®, IS-95 standards
  - TDMA: GSM, IS-136, EDGE/ UWC-136 standards
- Fixed wireless transmitters
- Cable modem termination systems

The DAC5687 is a dual-channel, 16-bit, high-speed DAC with integrated 2x, 4x and 8x interpolation filters, a complex numerical control oscillator (NCO), onboard clock multiplier, I/Q compensation and on-chip voltage reference. The DAC5687 is pin compatible with the DAC5686, requiring only changes in register settings for most applications, and offers additional features and superior linearity, noise, crosstalk and PLL phase noise performance.

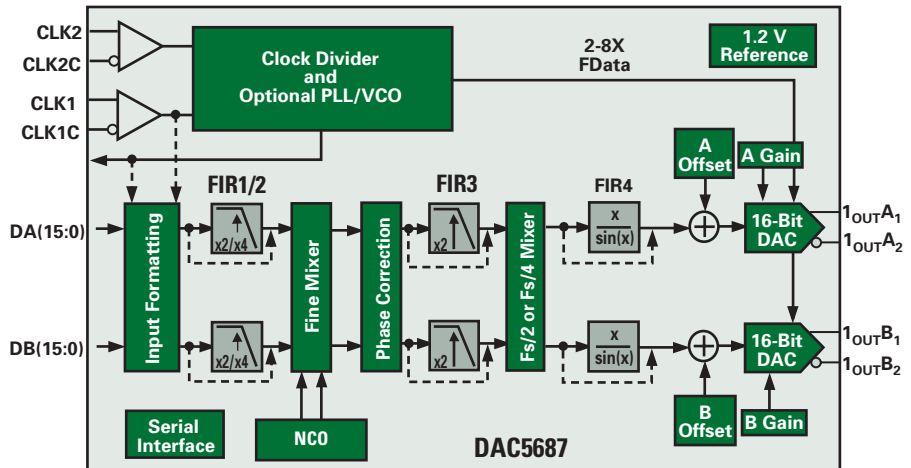

DAC5687 functional block diagram.

### Current Steering DACs Selection Guide

Device	Res. (Bits)	Supply (V)	Update Rate (MSPS)	Settling Time (ns)	Number of DACs	Power (mW) (typ)	DNL (±LSB) (max)	INL (±LSB) (max)	Package(s)	Price*
<b>DAC5687</b>	16	1.8/3.3	500	10.4	2	700	4	4	HTQFP-100	\$22.50
DAC5686	16	1.8/3.3	500	12	2	400	9	12	HTQFP-100	\$19.75
DAC904	14	3.0 to 5.0	165	30	1	170	1.75	2.5	SOP-28, TSSOP-28	\$6.25
<b>DAC5672</b>	14	3.0 to 3.6	200	20	2	330	3	4	TQFP-48	\$13.25
DAC2904	14	3.3 to 5.0	125	30	2	310	4	5	TQFP-48	\$20.19
DAC5675	14	3	400	5	1	820	2	4	HTQFP-48	\$29.45
DAC902	12	3.0 to 5.0	165	30	1	170	1.75	2.5	SOP-28, TSSOP-28	\$6.25
THS5661A	12	3.0 to 5.0	125	35	1	175	2.0	4	SOP-28, TSSOP-28	\$6.25
<b>DAC5662</b>	12	3.0 to 3.6	200	20	2	330	2	2	TQFP-48	\$10.70
DAC2902	12	3.3 to 5.5	125	30	2	310	2.5	3	TQFP-48	\$15.41
DAC2932	12	2.7 to 3.3	40	25	2	29	0.5	2	TQFP-48	\$7.95
DAC5674	12	1.8/3.3	400	20	1	420	2	3.5	HTQFP-48	\$15.00
DAC900	10	3.0 to 5.0	165	30	1	170	0.5	1	SOP-28, TSSOP-28	\$4.25
THS5651A	10	3.0 to 5.0	125	35	1	175	0.5	1	SOP-28, TSSOP-28	\$4.25
DAC2900	10	3.3 to 5.5	125	30	2	310	1	1	TQFP-48	\$6.00
<b>DAC5652</b>	10	3.0 to 3.6	275	20	2	290	1	0.5	TQFP-48	\$7.60
DAC908	8	3.0 to 5.0	165	30	1	170	0.5	0.5	SOP-28, TSSOP-28	\$2.90
THS5641A	8	3.0 to 5.0	100	35	1	100	0.5	1.0	SOP-28, TSSOP-28	\$2.90
THS5602	8	4.75 to 5.25	30	30	1	80	0.5	0.5	SOP-20	\$1.55

\*Suggested resale price in U.S. dollars in quantities of 1,000.

New products are listed in bold red.



## → Analog Monitoring and Control/Fan Controllers

Data acquisition system products from TI come with a reputation for high performance and integration along with the design flexibility required for a broad range of applications such as motor control, smart sensors for fan control, low-power monitoring and control, instrumentation systems, tunable lasers and optical power monitoring.

For motor control and three-phase power control, TI offers the new ADS7869. The ADS7869 is a 12-channel, 12-bit data

acquisition system featuring simultaneous sampling with three 12-bit SAR ADCs at 1MSPS with serial and parallel interface for high-speed data transfer and data processing.

The AMC1210 is a four-channel, digital sync filter designed to work with our family of current-shunt and Hall Effect sensor delta-sigma modulators to simplify the completion of the ADC function. The AMC1210 has four individual digital filters that can be used independently

with combinations of ADS1202, ADS1203, ADS1204, ADS1205 and ADS1208. It can also be used with the future AMC1203 device with built-in isolation.

The AMC7823 is a highly-integrated data acquisition and control device that has eight multiplexed analog inputs into a 12-bit, 200kSPS SAR ADC and eight analog voltage outputs from the internal eight 12-bit DACs.

### Analog Monitoring and Control Circuit

#### AMC7823

Get samples, datasheets, EVMs and app reports at: [www.ti.com/sc/device/AMC7823](http://www.ti.com/sc/device/AMC7823)

#### Key Features

- 12-bit, 200kSPS ADC
  - 8 analog inputs
  - Input range: 0 to  $2 \times V_{REF}$
- Programmable  $V_{REF}$ , 1.25V or 2.5V
- Eight 12-bit DACs (2 $\mu$ s settling time)
- Internal bandgap reference
- On-chip temperature sensor
- Precision current source
- SPI interface, 3V or 5V logic compatible
- Single supply: 3V to 5V
- Power-down mode
- Packaging: QFN-40 (6x6mm)

#### Applications

- Communications equipment
- Optical networks
- ATE
- Industrial control and monitoring
- Medical equipment

The AMC7823 is a complete analog monitoring and control circuit that includes an 8-channel, 12-bit ADC, eight 12-bit DACs, four analog input out-of-range alarms and six GPIOs to monitor analog signals and to control external devices. Also included are an internal sensor to monitor chip temperature and a precision current source to drive remote thermistors or RTDs to monitor remote temperatures.

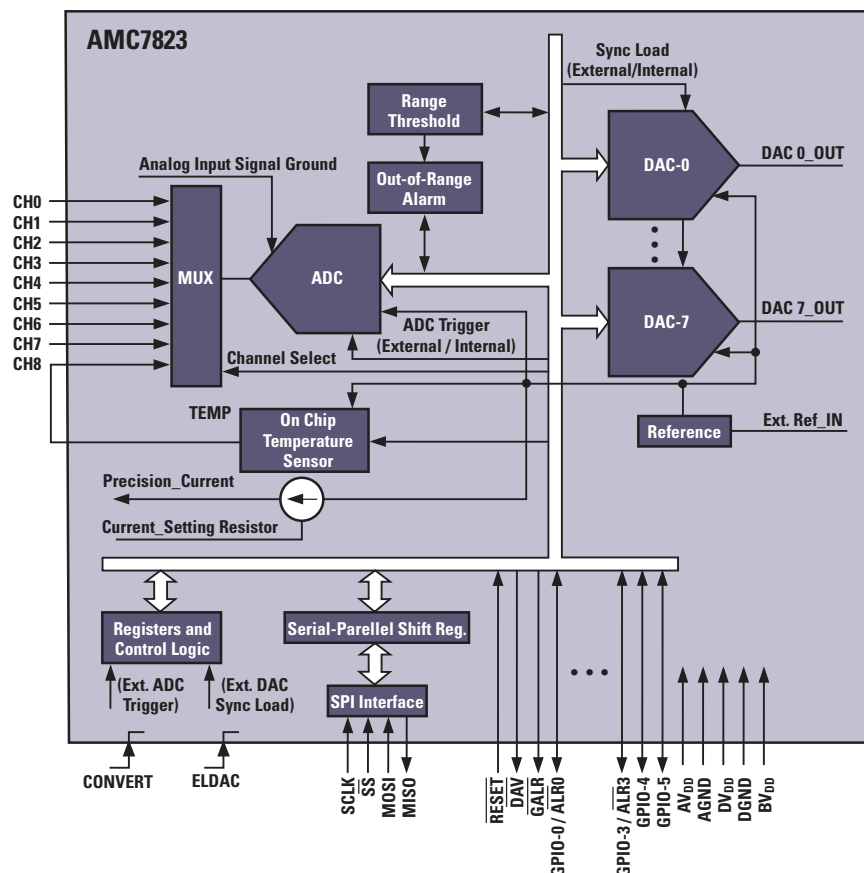

AMC7823 functional block diagram.

## Analog Monitoring and Control/Fan Controllers



### 1-Bit, 10MHz, 2nd-Order, Delta-Sigma Modulators for Motor Control

#### ADS120x

Get samples, datasheets, EVMs and app reports at: [www.ti.com/sc/device/ADS1202](http://www.ti.com/sc/device/ADS1202) and [www.ti.com/sc/device/ADS1203](http://www.ti.com/sc/device/ADS1203)

#### Key Features

- Resolution: 16-bits
- Linearity:
  - 13-bit, ADS1202
  - 14-bit, ADS1203
- Input range:  $\pm 1250\text{mV}$  with +5V single supply
- 1% internal voltage reference (ADS1203)
- 1% gain error (ADS1203)
- Flexible serial interface with four different modes
- Implemented twinned binary coding as split-phase or Manchester coding for one-line interfacing
- Packaging: TSSOP-8, QFN-16 (3x3mm)

#### Applications

- Motor control
- Current measurement
- Industrial process control
- Instrumentation
- Smart transmitters
- Weigh scales

The ADS1202 current shunt modulator and the ADS1203 current measurement modulator are designed for use in medium- to high-resolution measurement applications. Both operate from a single +5V supply, have differential inputs which are ideal for direct connection to transducers or low-level signals, and with the appropriate digital filter and modulator rate, can be used to achieve 16-bit ADC conversion with no missing codes.

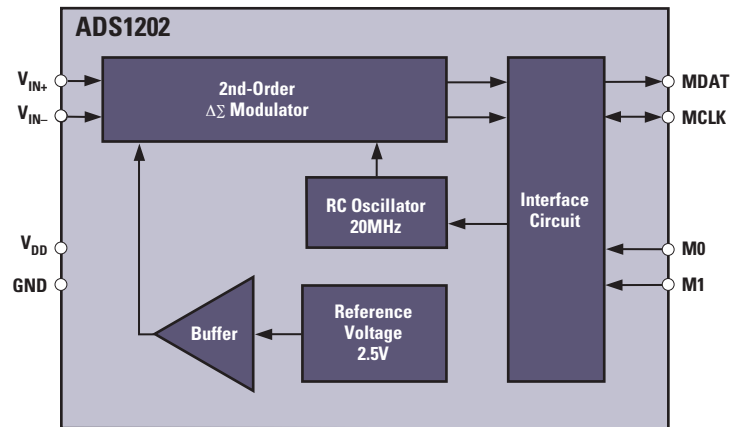

ADS1202 functional block diagram.

### Intelligent Fan Controller with I<sup>2</sup>C Interface

#### AMC6821

PREVIEW\*

Get samples, datasheets, EVMs and app reports at: [www.ti.com/sc/device/AMC6821](http://www.ti.com/sc/device/AMC6821)

#### Key Features

- Remote/local temperature sensor range:
  - +50°C to +100°C,  $\pm 1^\circ\text{C}$
  - -25°C to +125°C,  $\pm 3^\circ\text{C}$
- Resolution: 0.125°C
- PWM controller
  - Frequency: 10 to 40kHz
  - Duty cycle: 0 to 100%, 8-bits
- Automatic fan speed control loops
- SMB interface
- Power: 2.7V to 5.5V
- Packaging: QFN-16 (4x4mm), SSOP-16

#### Applications

- Notebook PCs
- Network servers
- Desktop PCs
- Telecommunication equipment
- PC-based equipment

The AMC6821 is an analog interface circuit with an integrated temperature sensor to measure the ambient temperature and one remote diode sensor input to measure external (CPU) temperature—ideal for notebook and desktop PC applications. It also includes a PWM controller, automatic fan speed control loops and SMB interface. See page 84 for specifications.

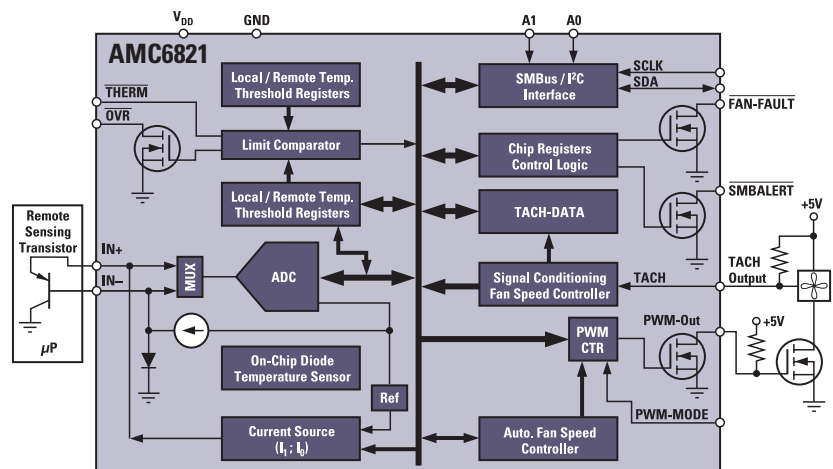

AMC6821 functional block diagram.

\*Expected AMC6821 release date, 3Q 2006

## ➔ Analog Monitoring and Control/Fan Controllers

### 16-Bit, 250kHz, 6-Channel ADC

#### ADS8365

PREVIEW\*

Get datasheets at: [www.ti.com/sc/device/ADS8365](http://www.ti.com/sc/device/ADS8365)

#### Key Features

- Six input channels
- Fully differential inputs
- Six independent 16-bit ADCs
- 4μs throughput per channel
- Tested no missing codes to 15 bits
- Low power:
  - Normal mode: 200mW
  - Nap mode: 50mW
  - Power-down mode: 50μW
- Pin compatible to ADS8364
- Packaging: TQFP-64

#### Applications

- Motor control
- Multi-axis positioning systems
- 3-phase power control

The ADS8365 includes six, 16-bit, 250kHz ADCs with six fully differential input channels grouped into two pairs for high-speed simultaneous signal acquisition. The ADS8365 architecture provides excellent common-mode rejection of 80dB at 50kHz—ideal for high-noise environments. It also includes a high-speed parallel interface with a direct address mode, a cycle and a FIFO mode.

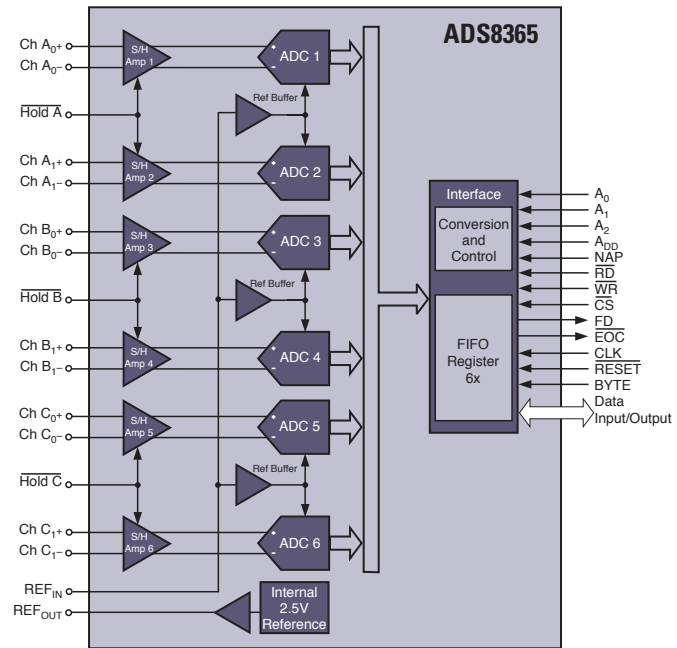

ADS8365 functional block diagram.

\*Expected release date 3Q 2006

## Analog Monitoring and Control

Device	Res. (Bits)	Sample Rate (kSPS)	Number of Input Channels	Interface	Input Voltage (V)	V <sub>REF</sub>	Linearity (%)	NMC (Bits)	SINAD (dB)	Power (mW)	Package	Price*
ADS1201	24	4	1 SE/1 Diff	Serial	5	Int/Ext	0.0015	24	—	25	SOIC-16	\$6.15
<b>AMC1210</b>	16	90MHz Clock	4 Digital Filters	Serial/P4	Digital Bit Stream	—	—	—	—	1.5/MHz/Ch	QFN-40	\$1.55
ADS8361	16	500	2 x 2 Diff	Serial, SPI	±2.5 at 2.5	Int/Ext	0.0012	14	83	150	SSOP-24	\$8.75
ADS8364	16	250	1 x 6 Diff	P16	±2.5 at 2.5	Int/Ext	0.009	14	82.5	413	TQFP-64	\$18.10
<b>ADS8365</b>	16	250	1 x 6 Diff	P16	±2.5 at 2.5	Int/Ext	0.006	15	87	200	TQFP-64	\$17.00
ADS1202	16	40	1 SE/1 Diff	Serial	±0.25	Int/Ext	0.018	16	—	33	TSSOP-8	\$2.50
ADS1203	16	40	1 SE/1 Diff	Serial	±0.25	Int/Ext	0.003	16	—	33	TSSOP-8	\$2.70
<b>ADS1208</b>	16	40	1 SE/1 Diff	Serial	±0.125	Int/Ext	0.012	16	—	64	TSSOP-16	\$2.95
<b>ADS1205</b>	16	40	2 Diff	Serial	±2.5 at 2.5	Int/Ext	0.005	16	—	75	QFN-24	\$3.95
ADS1204	16	40	4 SE/4 Diff	Serial	±2.5 at 2.5	Int/Ext	0.003	16	—	122	QFN-32	\$6.75
ADS7871	14	40	8 SE/4 Diff	Serial, SPI	PGA (1,2,4,8,10,16,20)	Int/Ext	0.03	13	—	6	SSOP-28	\$5.00
<b>ADS7869</b>	12	1000	12 Diff	Serial, SPI/P12	±2.5 at ±2.5	Int	0.06	11	71	175	TQFP-100	\$14.60
ADS7861	12	500	2 x 2 Diff	Serial, SPI	±2.5 at 2.5	Int/Ext	0.024	12	70	25	SSOP-14	\$4.05
ADS7862	12	500	2 x 2 Diff	P12	±2.5 at 2.5	Int/Ext	0.024	12	71	25	TQFP-32	\$5.70
ADS7864	12	500	3 x 2 Diff	P12	±2.5 at 2.5	Int/Ext	0.024	12	71	50	TQFP-48	\$6.65
<b>AMC7823</b>	12	200	8 SE I/O DAS	Serial, SPI	5	Int/Ext	0.024	12	74	100	QFN-40	\$9.75
AMC7820	12	100	8 DAS	Serial, SPI	5	Int	0.024	12	72 (typ)	40	TQFP-48	\$3.75
ADS7870	12	50	8 SE	Serial, SPI	PGA (1,2,4,8,10,16,20)	Int	0.06	12	72	4.6	SSOP-28	\$4.15

\*Suggested resale price in U.S. dollars in quantities of 1,000.

New products are listed in bold red. Preview products are listed in bold blue.

## Digital Current Shunt Monitors



The ADS120x series are 2nd-order, precision, delta-sigma ( $\Delta\Sigma$ ) modulators operating from a single +5V supply at a 10MHz clock rate, specifically used in motor control applications for measuring and digitizing motor current. The targeted application is servo motor control.

Both the ADS1202 and ADS1203 modulators have an input range set for  $\pm 250\text{mV}$  to directly digitize current passing through a

shunt resistor. The ADS1204 and ADS1205 are optimized for magnetic-based current sensors and feature two and four input channels. In contrast, the ADS1208 is optimized for Hall Effect sensors. It has integrated all the key components needed to directly connect the sensor, including a programmable current source for the sensor excitation and internal operational amplifiers to buffer the analog input.

With the appropriate digital filter and modulator rate, provided by the AMC1210, the ADS120x will achieve 16-bit analog-to-digital conversion performance with no missing codes. They also offer excellent INL, DNL and low distortion at 1kHz. They feature low power and are available in a TSSOP and QFN packages.

See page 27 for a complete selection of analog current shunt monitors.

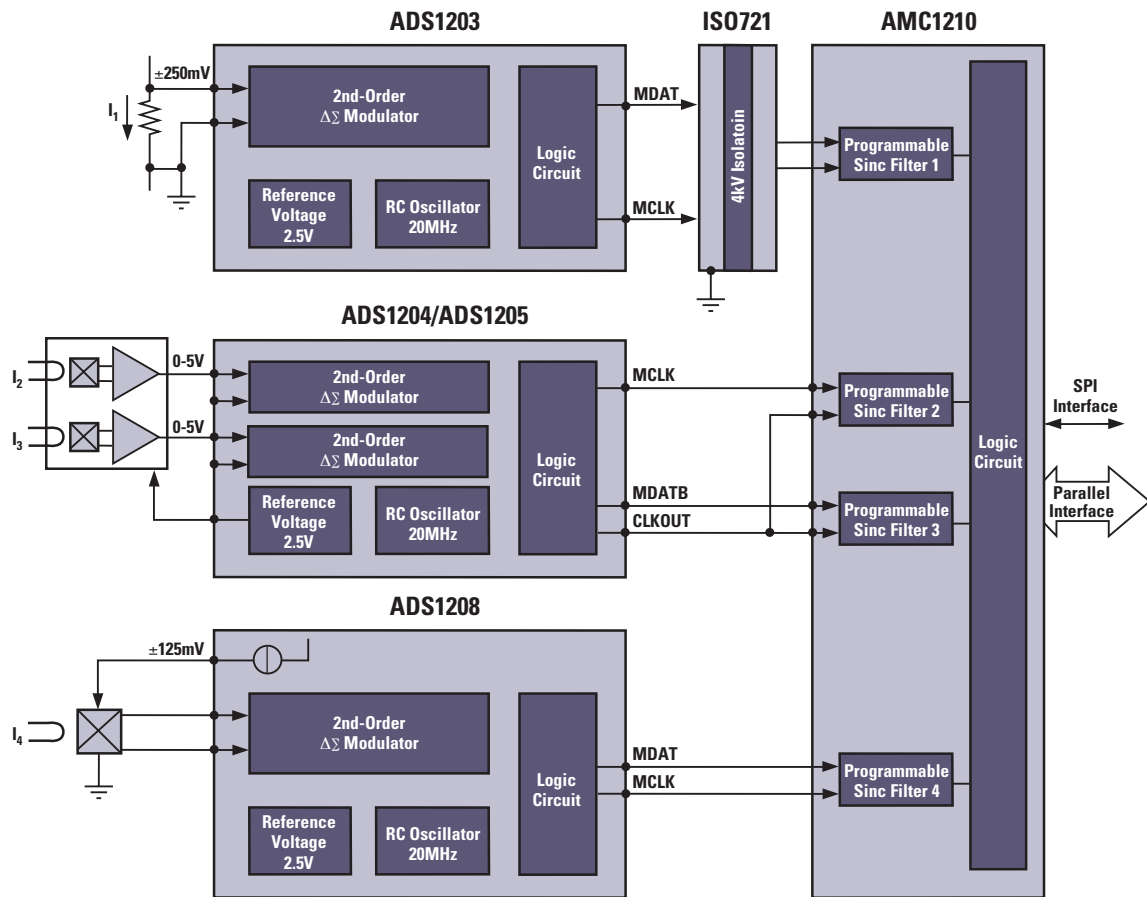

Possible input modulator configuration for current measurement with AMC1210 digital filter.

## Analog Monitoring and Control ADCs Selection Guide

Device	Res. (Bits)	Sample Rate (kSPS)	Number of Input Channels	Interface	Input Voltage (V)	$V_{REF}$	Linearity (%)	NMC (Bits)	SINAD (dB)	Power (mW)	Package(s)	Price*
<b>ADS1202</b>	16	10MHz Clock	1 SE/1 Diff	Serial	$\pm 0.25$	Int/Ext	0.018	16	70	30	TSSOP-8	\$2.50
<b>ADS1203</b>	16	10MHz Clock	1 SE/1 Diff	Serial	$\pm 0.25$	Int/Ext	0.005	16	85	33	TSSOP-8, QFN-16	\$2.70
<b>ADS1204</b>	16	10MHz Clock	4 SE/4 Diff	Serial	$\pm 2.5$ at 2.5	Int/Ext	0.005	16	89	122	QFN-32	\$6.75
<b>ADS1205</b>	16	10MHz Clock	2 SE/2 Diff	Serial	$\pm 2.5$ at 2.5	Int/Ext	0.005	16	88	59	QFN-24	\$3.95
<b>ADS1208</b>	16	10MHz Clock	1 SE/1 Diff	Serial	$\pm 0.125$	Int/Ext	0.012	16	81	64	TSSOP-16	\$2.95

\*Suggested resale price in U.S. dollars in quantities of 1,000.

New products are listed in bold red.

## → Voltage References

### Precision Voltage and Current References

TI's family of voltage and current references incorporates state-of-the-art technology to offer stable, high-precision, high-performance references in tiny packages.

### Series Voltage References

Series voltage references are known for excellent accuracy and stability over temperature. Typically three terminal devices, series voltage references are often used to provide stable reference voltages for ADCs and microcontrollers.

The REF29xx, REF30xx, REF31xx and REF32xx are TI's newest available families of precision, low-power, low-dropout, series voltage references in tiny SOT23-3 packages. Drift specifications range from 100ppm/°C to less than 10ppm/°C. Small size and low power consumption (100µA typ) make them ideal for portable and battery-powered applications.

These voltage references are stable with any capacitive load and can sink/source a minimum of up to 10mA of output current and are specified for the temperature range of -40°C to +125°C.

### Shunt Voltage References

Shunt voltage references are precision diodes designed to offer good accuracy at extremely low power. These devices require a current source, typically a supply voltage and pull-up resistor to keep forward biased.

The REF1112 is a 1µA, two-terminal reference diode designed for high accuracy with outstanding temperature characteristics at low operating currents. Precision thin-film resistors result in 0.2% initial voltage accuracy and 50ppm/°C maximum temperature drift. The REF1112 is specified from -40°C to +85°C, with operation from 1µA to 5mA, and is offered in a SOT23-3 package.

### Current References

Many applications require the use of a precision current source or current sink. The REF200 combines three circuit building-blocks on a single monolithic chip—two 100µA current sources and a current mirror capable of being used as a current source or sink.

### Integrated Op Amp and Voltage References

For applications requiring an op amp plus voltage reference or comparator plus voltage reference, TI has an offering of integrated function voltage references. The TLV3011 and TLV3012 are low-power, (5µA) 6µs propagation delay comparators with an integrated shunt voltage reference.

See pages 23 and 24 for comparator and integrated voltage reference specifications

## 30ppm/°C, 1µA, 1.25V Shunt Voltage Reference REF1112

Get samples, datasheets, EVMs and app reports at: [www.ti.com/sc/device/REF1112](http://www.ti.com/sc/device/REF1112)

### Key Features

- µPower: 1µA
- Specified drift:
  - 30ppm/°C (max) 0°C to +70°C
  - 50ppm/°C (max) -40°C to +125°C
- High accuracy: 0.02% (max)
- Packaging: microSize SOT23-3

### Applications

- Portable equipment
- Battery powered instruments
- Calibration equipment
- microPower voltage or current references

The REF1112 is a two-terminal shunt voltage reference designed to complement precision, low-power designs. Featuring 1µA of supply current and an initial accuracy of 0.2%, the REF1112 is an excellent complement to other 1µA components from TI, such as the TLV349x comparator and the OPA349 operational amplifier. The REF1112 is available in a SOT23-3 package, and is specified from -40°C to +85°C.

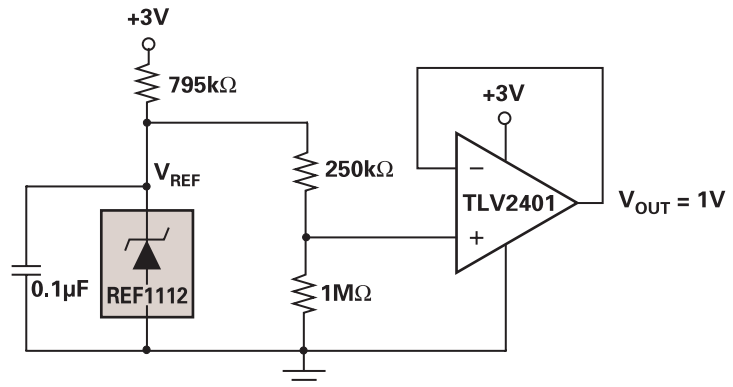

REF1112 low-power reference voltage.





## 7ppm/°C Precision Series Voltage References

### REF3212, REF3220, REF3225, REF3230, REF3233, REF3240

Get samples and datasheets at: [www.ti.com/sc/device/PARTnumber](http://www.ti.com/sc/device/PARTnumber) (Replace **PARTnumber** with **REF3212, REF3220, REF3225, REF3230, REF3233** and **REF3240**)

#### Key Features

- Specified drift:
  - 7ppm/°C (max) 0°C to +125°C
  - 20ppm/°C (max) -40°C to +125°C
- High output current: ±10mA
- High accuracy: 0.01% (typ)
- Low supply current: 100µA
- Low dropout: 5mV
- Packaging: microSize SOT23-6

#### Applications

- Portable equipment
- Data acquisition systems
- Medical equipment
- Test equipment

The REF32xx is TI's first 7ppm/°C voltage reference. This low-power voltage reference offers precision output voltages in a tiny SOT23-6 package. The reference is ideal for portable and battery-powered applications, is stable with any capacitive load, and is capable of sinking or sourcing up to 10mA of output current. Minimum operating voltage for the REF32xx family is 5mV above the specified output voltage, and devices are specified from -40°C to +125°C.

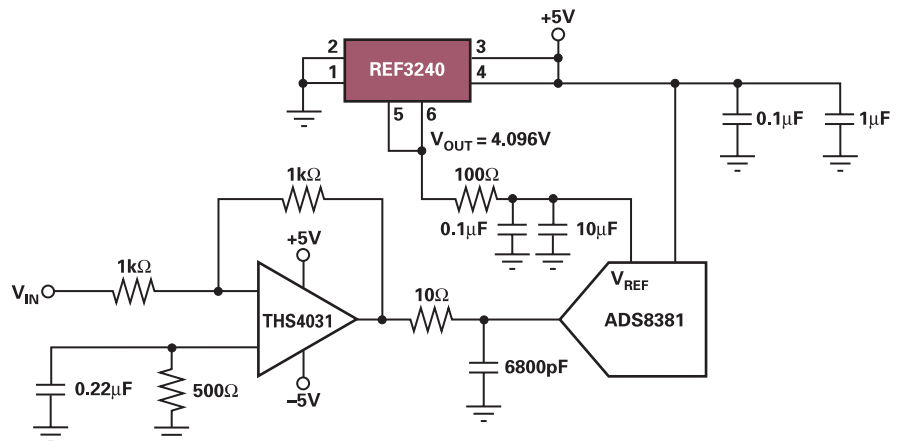

REF3220 used as precision reference in 16-bit ADC application.

## Voltage References Selection Guide

Device	Description	Output (V)	Initial Accuracy (%) (max)	Drift (ppm/°C) (max)	Long-Term Stability (ppm/1000hr) (typ)	Noise 0.1 to 10Hz (µVp-p) (typ)	I <sub>Q</sub> (mA) (max)	Temperature Range (°C)	Output Current (mA)	Package(s)	Price*
<b>REF32xx</b>	Low Drift, Bandgap	1.25, 2.048, 2.5, 3.0, 3.3, 4.096	0.2	7	24	17 to 53	0.1	0 to +125	±10	SOT23-6	\$1.70
REF31xx	Bandgap	1.25, 2.048, 2.5, 3.0, 3.3, 4.096	0.2	15	24	15 to 30	0.1	-40 to +125	±10	SOT23-3	\$1.10
<b>REF33xx</b>	microPower, Bandgap	1.25, 2.048, 2.5, 3.0, 3.3, 4.096	0.1	30	24	35 to 80	0.005	-40 to +125	±5	SC-70	\$0.95
REF30xx	Bandgap	1.25, 2.048, 2.5, 3.0, 3.3, 4.096	0.2	50	24	20 to 45	0.05	-40 to +125	25	SOT23-3	\$0.59
REF29xx	Bandgap	1.25, 2.048, 2.5, 3.0, 3.3, 4.096	2	100	24	20 to 45	0.05	-40 to +125	25	SOT23-3	\$0.49
REF02A	Low Drift, Buried Zener	5	0.19	15	50	4	1.4	-25 to +85	+21, -0.5	SOIC-8	\$1.65
REF02B	Low Drift, Buried Zener	5	0.13	10	50	4	1.4	-25 to +85	+21, -0.5	SOIC-8	\$2.27
REF102A	Low Drift, Buried Zener	10	0.1	10	20	5	1.4	-25 to +85	+10, -5	SOIC-8	\$1.65
REF102B	Low Drift, Buried Zener	10	0.05	5	20	5	1.4	-25 to +85	+10, -5	SOIC-8	\$4.15
REF102C	Ultra-Low Drift, Buried Zener	10	0.025	2.5	20	5	1.4	-25 to +85	+10, -5	SOIC-8	\$4.85
<b>Shunt</b>											
REF112	µPower, 1.25V Shunt	1.25	0.2	30	60	25	0.0012	-40 to +125	1A to 5mA	SOT-23	\$0.85
<b>Current Reference</b>											
REF200	Dual Current Reference with Current Mirror	100µA/Channel	±1µA	25 (typ)	—	1µAp-p	—	-25 to +85	50µA to 400µA	PDIP-8, SOIC-8	\$2.60

\*Suggested resale price in U.S. dollars in quantities of 1,000.

New products are listed in bold red.  
Preview products are listed in bold blue.

## → Temperature Sensors

### Digital Temperature Sensors

TI's high-accuracy, low-power temperature sensors are specified for operation from  $-40^{\circ}\text{C}$  to  $+125^{\circ}\text{C}$  and are designed for cost-effective thermal measurement in a variety of communication, computer, consumer, industrial and instrumentation applications.

These silicon-based temperature sensors are designed on a unique topology that offers excellent accuracy and linearity over temperature. Low power and standard communication protocol pair nicely with low-power microcontrollers and battery-powered designs.

The digital temperature output of the TMP family is created using a high-performance, 12-bit, delta-sigma ADC that outputs temperatures as a digital word. Programming and communication with the TMP1xx family of devices is done via an  $\text{I}^2\text{C}/2\text{-wire}$  or SPI interface for easy integration into existing digital systems.

### Temperature Sensor Core

A typical block diagram of the TMP family of digital temperature sensors is shown below. Temperature is sensed through the die flag of the lead frame where the temperature sensing element is the chip itself, ensuring the most accurate temperature information of the monitored area and allowing designers to respond quickly to "over" and "under" thermal conditions.

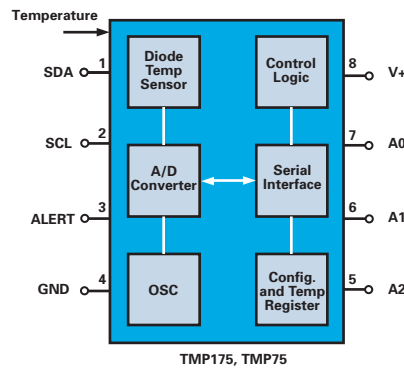

Typical block diagram of the TMP family of digital temperature sensors.

### Features of TMP Digital Temperature Sensors

Several TMP digital sensors offer programmable features, including over- and under-temperature thresholds, alarm functions and temperature resolution. With extremely low power consumption in active ( $50\mu\text{A}$ ) and standby ( $0.1\mu\text{A}$ ) modes, the TMP12x family offers as low as  $1.5^{\circ}\text{C}$  minimum error in a SOT23 package and is an excellent candidate for low-power thermal monitoring applications.

The new **TMP105** and **TMP106** are the world's smallest digital temperature sensors. Available in a tiny  $1\text{mm} \times 1.5\text{mm}$  chip-scale package, they use only  $50\mu\text{A}$  of current and are ideal for portable applications including mobile phones, portable media players, digital still cameras, hard disk drives, laptops, and computer accessories. TMP105 has 1.8V to 3.0V logic, while TMP106 has 2.7V to 5.5V logic.

### Resistor-Programmable, Low-Power Temperature Switch in SC70

#### TMP300

PREVIEW\*

Get samples, datasheets, EVMs and app reports at: [www.ti.com/sc/device/TMP300](http://www.ti.com/sc/device/TMP300)

#### Key Features

- Stand-alone operation
- Resistor-programmable trip point  $\pm 4^{\circ}\text{C}$  (max) error over  $-40^{\circ}\text{C}$  to  $+125^{\circ}\text{C}$
- Programmable hysteresis:  $5^{\circ}\text{C}/10^{\circ}\text{C}$
- Analog output:  $10\text{mV}/^{\circ}\text{C}$
- Open-drain output
- Low power:  $90\mu\text{A}$  (max)
- Wide supply range: 1.8V to 18V
- $-40^{\circ}\text{C}$  to  $+150^{\circ}\text{C}$  operation
- Packaging: SC70-6

#### Applications

- Power supplies
- DC/DC converters
- Thermal monitoring
- Electronic protection systems

The TMP300 is an easy-to-use resistor-programmable, low-power temperature switch with auxiliary analog output. It allows a temperature threshold point to be set by adding an external resistor. Two levels of hysteresis are available. TMP300 also has an analog output ( $V_{\text{TEMP}}$ ) that can be used as a testing point or in temperature compensation loops. With a supply voltage as low as 1.8V, low current consumption and a tiny SC70 package, the TMP300 is ideal for power- and space-sensitive applications.

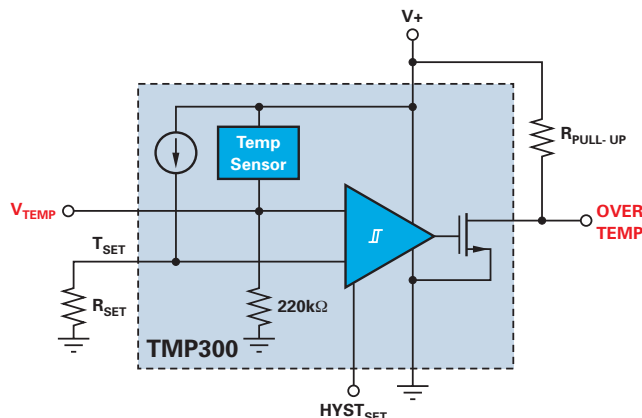

TMP300 functional block diagram. \*Expected TMP300 release date, 3Q 2006

**NEW**

**World's Smallest Digital Temperature Sensors**

**TMP105, TMP106**

Get samples, datasheets, EVMs and app reports at: [www.ti.com/sc/device/TMP105](http://www.ti.com/sc/device/TMP105) and [www.ti.com/sc/device/TMP106](http://www.ti.com/sc/device/TMP106)

**Key Features**

- Digital output: two-wire serial interface
- 2 addresses
- Resolution: 9- to 12-bits, user-selectable
- High accuracy:
  - $\pm 2.0^{\circ}\text{C}$  (max) from  $-25^{\circ}\text{C}$  to  $+85^{\circ}\text{C}$
  - $\pm 3.0^{\circ}\text{C}$  (max) from  $-40^{\circ}\text{C}$  to  $+125^{\circ}\text{C}$
- Low supply current:  $50\mu\text{A}$ ,  $0.1\mu\text{A}$  in shutdown mode
- No power-up sequence required
- I<sup>2</sup>C pull-ups can be enabled prior to V+
- TMP105: 1.8V to 3.0V logic
- TMP106: 2.7V to 5.5V logic
- Packaging: 1mm x 1.5mm chipscale

**Applications**

- Mobile phones
- Portable media players
- Hard disk drives
- Notebook computers
- Portable devices
- Environmental monitoring

Featuring a 1mm x 1.5mm chipscale package and ultra-low-power operation, TMP105 and TMP106 are ideal for temperature monitoring in battery-powered and portable applications. Utilizing an on-chip delta-sigma ADC and the most modern process technology, TMP105 and TMP106 are complete temperature-to-digital converters. TMP105 and TMP106 are small, simple, low-power replacements for a thermistor +  $\mu\text{C}$  ADC, and significantly reduce overall system power consumption. Using the "one-shot" mode, 9-bit resolution, and 1SPS, average power consumption can be reduced to  $2\mu\text{A}$ . Digital temperature sensors also offer more robust EMC performance than analog temp sensors in noisy designs. Perfect for use with OMAP™, DaVinci™ and MSP430 processors.

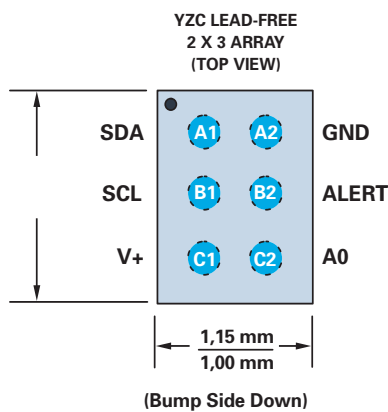

Note: Pin A1 is marked with a '0' for Pb- Free (YZC)

*TMP106 design topology.*

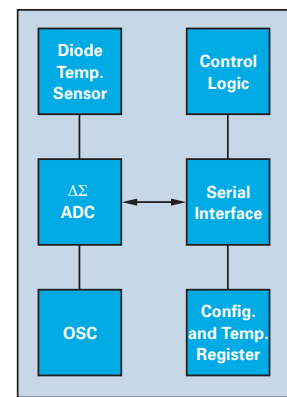

*TMP106 functional block diagram.*

**Digital Temperature Sensor With I<sup>2</sup>C Interface**

**TMP75**

Get samples, datasheets, EVMs and app reports at: [www.ti.com/sc/device/TMP75](http://www.ti.com/sc/device/TMP75)

**Key Features**

- Two-wire/SMBus compatible interface
- High accuracy
  - $2.0^{\circ}\text{C}$  (max) ( $-25^{\circ}\text{C}$  to  $+85^{\circ}\text{C}$ )
  - $3.0^{\circ}\text{C}$  (max) ( $-40^{\circ}\text{C}$  to  $+125^{\circ}\text{C}$ )
- Low power
  - $50\mu\text{A}$  (Active mode)
  - $0.1\mu\text{A}$  (Standby mode)
- 9- to 12-bit user-selectable resolution
- Operation: 2.7V to 5.5V
- SMBus alert function
- 8 addresses (TMP175: 27 addresses)
- Packaging: MSOP-8, SOIC-8

TMP75 is a lower power, higher accuracy replacement for LM75. Featuring 9- to 12-bit user-selectable resolution and support for the SMBus alert function, TMP75 is suitable for temperature monitoring in a wide range of applications.

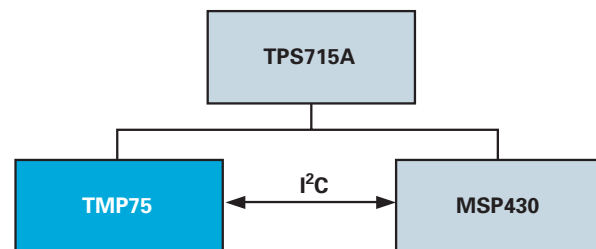

*TMP75 configured as low-power, low-cost thermostat.*

## → Temperature Sensors

### Temperature Sensors Selection Guide

Device	Description	Accuracy	Specified Temp Range (°C)	Operating Temp Range (°C)	Temp Resolution (Bits)	Supply Voltage (V)	I <sub>Q</sub> (μA) (typ)	Package(s)	Price*
		Over Temp Range (°C max)							
<b>I<sup>2</sup>C/SMBus Interface</b>									
TMP100	Digital Temp Sensor	3 2	-55 to +125 -25 to +85	-55 to +125	9 to 12	2.7 to 5.5	45	SOT-23	\$0.75
TMP101	Digital Temp Sensor with Prog. Thermostat/Alarm Function	3 2	-55 to +125 -25 to +85	-55 to +125	9 to 12	2.7 to 5.5	45	SOT-23	\$0.80
<b>TMP105</b>	Chipscale Digital Temp Sensor with 1.8V to 3.0V Logic	3 2	-40 to +125 -25 to +85	-55 to +127	9 to 12	2.7 to 5.5	50	1mm x 1.5mm WCSP	\$0.85
<b>TMP106</b>	Chipscale Digital Temp Sensor with 2.7V to 5.0V Logic	3 2	-40 to +125 -25 to +85	-55 to +127	9 to 12	2.7 to 5.5	50	1mm x 1.5mm WCSP	\$0.85
<b>TMP275</b>	Ultra-High Accuracy Digital Temp Sensor	1.0 0.5	-40 to +25 +10 to +85	-55 to 127	9 to 12	2.7 to 5.5	50	MSOP	\$1.25
TMP175	Digital Temp Sensor with 2-Wire Interface, 27 Addresses	2 1.5	-40 to +125 -25 to +85	-55 to +127	9 to 12	2.7 to 5.5	50	SOIC	\$0.85
TMP75	Digital Temp Sensor with 2-Wire Interface, 8 Addresses	3 2	-40 to +125 -25 to +85	-55 to +127	9 to 12	2.7 to 5.5	50	MSOP, SOIC	\$0.70
<b>SPI Interface</b>									
TMP121	1.5°C Accurate Digital Temp Sensor with SPI Interface	2 1.5	-40 to +125 -25 to +85	-55 to +150	12	2.7 to 5.5	35	SOT-23	\$0.90
TMP122	1.5°C Accurate Programmable Temp Sensor with SPI Interface	2 1.5	-40 to +125 -25 to +85	-55 to +150	9 to 12	2.7 to 5.5	50	SOT-23	\$0.99
TMP123	1.5°C Accurate Digital Temp Sensor with SPI Interface	2 1.5	-55 to +125 -25 to +85	-55 to +150	12	2.7 to 5.5	35	SOT-23	\$0.90
TMP124	1.5°C Accurate Programmable Temp Sensor w/SPI Interface	2 1.5	-40 to +125 -25 to +85	-55 to +150	9 to 12	2.7 to 5.5	50	SOIC	\$0.70
TMP125	2°C Accurate Digital Temp. Sensor with SPI Interface	2.5 2	-40 to +125 -25 to +85	-55 to +125	10	2.7 to 5.5	36	SOT-23	\$0.80
<b>Single-Wire, SensorPath™ Interface</b>									
TMP141	Digital Temp Sensor with Single-Wire SensorPath Bus	3 2	-40 to +125 -25 to +85	-55 to +127	10	2.7 to 5.5	110	SOT-23, MSOP	\$0.65

### Temperature Switch

Device	Description	Trip Point	Output (mV/°C)	Specified Temp Range (°C)	Operating Temp Range (°C)	Supply Voltage (V)	I <sub>Q</sub> (μA) (max)	Package	Price*
		Accuracy (°C) (typ)							
<b>TMP300</b>	Comparator-Output Temperature Switch with Additional Analog Output	±1	10	-40 to +125	-40 to +150	1.8 to 18	90	SC-70	\$0.75

### Fan Controller

Device	Description	Accuracy	Input	Fan Control Modes	Output	I <sub>Q</sub> (mA)	Supply Voltage (V)	Interface	Package(s)	Price*
		(°C)								
<b>AMC6821</b>	±1°C Remote and Local Temp Sensors with Integrated Fan Controller	±1	1 Local and 1 Remote Temp	Programmable, Automatic, and Fixed RPM	Programmable PWM Frequency and Duty Cycle	3 (active) 0.05 (shutdown)	2.7 to 5.5	I <sup>2</sup> C/SMBus	SOP-16 4mm x 5mm QFN-16 4mm x 4mm	Contact TI for Price

\*Suggested resale price in U.S. dollars in quantities of 1,000.

New products are listed in bold red. Preview products are listed in bold blue.

## HiRel, Defense and Aerospace



The Texas Instruments HiRel team offers TI products in extended temperature ranges to support the military, defense and aerospace markets. Several different process flows are available including ceramic QML, QML-V for space and enhanced plastic (EP). While not

QML-qualified, these EP products can help reduce cost while providing many of the benefits of a QML device.

The TI HiRel group can qualify data converters and amplifiers included in this catalog, but not listed in the HiRel section.

For additional information about other HiRel parts or to inquire about additional part qualification, please contact the TI Product Information Center or visit these web sites:

[www.ti.com/military](http://www.ti.com/military)  
[www.ti.com/ep](http://www.ti.com/ep)  
[www.ti.com/space](http://www.ti.com/space)

### HiRel SAR ADCs

Device	Res. (Bits)	Sample Rate (kSPS)	Number of Input Channels	Interface	Input Voltage (V)	V <sub>REF</sub>	Linearity (%)	NMC	SINAD (dB)	Power (mW)	Package	Price*
TLC1543-EP	10	38	11 SE	Serial, SPI	V <sub>REF</sub>	Ext	0.1	10	—	4	SOIC-20	\$3.89
TLC2543-EP	12	66	11 SE	Serial, SPI	V <sub>REF</sub>	Ext	0.024	12	—	5	SOIC-20	\$9.85
TLV1548-EP	10	85	8 SE	Serial, SPI	V <sub>REF</sub>	Ext	0.1	10	—	1.05	SSOP-20	\$4.36
TLV2548M	12	200	8 SE	Serial, SPI	+2, 4	Int/Ext	0.024	12	71	3.3	LCCC-20	\$151.89

### HiRel ADCs

Device	Res. (Bits)	Sample Rate (kSPS)	Architecture	No. of Input Channels	SINAD (dB)	SNR (dB)	SFDR (dB)	INL (%)	DNL (±LSB)	NMC	V <sub>REF</sub>	Interface	No. of Supplies	Analog Supply	Logic Supply	Power (mW)	Price*
THS1206-EP	12	6MSPS	Pipeline	4 SE/2 Diff	65	69	71	1.8LSB	1	12	Int/Ext	P12	2	4.75, 5.25	3.5, 2.5	186	\$17.61
THS1401-EP	14	1MSPS	Pipeline	1 SE/1 Diff	70	72	80	5LSB	1	—	Int/Ext	P14	1	3, 3.6	3, 3.6	270	\$20.48
THS1403-EP	14	3MSPS	Pipeline	1 SE/1 Diff	70	72	80	5LSB	1	—	Int/Ext	P14	1	3, 3.6	3, 3.6	270	\$25.39
THS1408-EP	14	8MSPS	Pipeline	1 SE/1 Diff	70	72	80	5LSB	1	—	Int/Ext	P14	1	3, 3.6	3, 3.6	270	\$18.09
ADS5500-EP	14	125MSPS	Pipeline	1 Diff	70	70.5	82	-0.9/+1.1	5	14	Int	P14	1	3.0, 3.6	3.0, 3.6	780	\$190.00
TLC1543-EP	10	38	SAR	11 SE	—	—	—	0.1	1	10	Ext	Serial, SPI	1	4.5, 5.5	4.5, 5.5	4	\$3.89
TLC2543-EP	12	66	SAR	11 SE	—	—	—	0.024	1	12	Ext	Serial, SPI	1	4.5, 5.5	4.5, 5.5	5	\$9.85
TLV1548-EP	10	85	SAR	8 SE	—	—	—	0.1	1	10	Ext	Serial, SPI	1	2.7, 5.5	2.7, 5.5	1.05	\$4.36
TLV2548M	12	200	SAR	8 SE	71	—	75	1.2LSB	1	12	Int/Ext	Serial, SPI	1	2.7, 5.5	2.7, 5.5	3.3	\$151.89

### HiRel DACs

Device	Res. (Bits)	Settling Time (µs)	Architecture	Number of Channels	Update Rate (MSPS)	Output (V)	DNL (±LSB)	INL (%)	Monotonic (Bits)	Interface	V <sub>REF</sub>	Supply Voltage (V)	Power (mW) (typ)	Price*
TLC5618A	12	2.5	String	2	—	+V <sub>REF</sub>	1	0.1	12	Serial, SPI	Ext	4.5 to 5.5	3	\$28.23
TLC7226M	8	5	R-2R	4	—	+V <sub>REF</sub>	1	0.4	8	P8	Ext	± or + 11.4 to 16.5	90	\$78.98
TLV5618A-EP	12	2.5	String	2	—	+V <sub>REF</sub>	1	0.08	12	Serial, SPI	Ext	+2.7 to 5.5	1.8	\$11.78
TLV5618AM	12	3	String	2	—	+V <sub>REF</sub>	1	0.1	12	Serial, SPI	Ext	+2.7 to 5.5	1.8	\$28.23
TLV5619-EP	12	1	String	1	—	+V <sub>REF</sub>	1	0.08	12	P12	Ext	+ 2.7 to 5.5	4.3	\$7.91
TLV5638-EP	12	1	String	2	—	+2, 4	1	0.1	12	Serial, SPI	Int/Ext	+ 2.7 to 5.25	4.5	\$9.34
TLV5638M	12	1	String	2	—	+2, 4	1	0.1	12	Serial, SPI	Int/Ext	+ 2.7 to 5.25	4.5	\$32.50
DAC5675-EP	14	0.005	I-Steering	1	400	20mA	2	4LSB	—	LVDS/P14	Int/Ext	+ 3.15 to 3.6	820	\$50.00

### HiRel Amplifiers

Device	Description	Supply Voltage (V)	A <sub>CL</sub> (min)	BW at A <sub>CL</sub> (MHz) (typ)	BW G = +2 (MHz) (typ)	GBW Product (MHz) (typ)	Slew Rate (V/µs)	1V <sub>pp</sub> , G = 2, 5MHz		V <sub>N</sub> (nV/√Hz) (typ)	V <sub>OS</sub> (mV) (max)	I <sub>B</sub> (µA) (max)	I <sub>Q</sub> Per Ch. (mA) (typ)	I <sub>OUT</sub> (mA) (typ)	Package(s)	Price*
								HD <sub>2</sub> (dBc) (typ)	HD <sub>3</sub> (dBc) (typ)							
OPA698M	Voltage Limiting, VFB	5, ±5	1	450	215	250	1100	-82	-88	5.6	5	10	15.5	120	CDIP	\$14.85
OPA699M	Voltage Limiting, VFB	5, ±5	4	260	—	1000	1400	—	—	4.1	5	10	15.5	120	CDIP	\$14.85
THS3201-EP	1.8GHz, Low Distortion, CFB	±5, ±7.5	1	1800	850	—	6200	-85	-95	1.65	3	13	14	115	MSOP PowerPAD™	\$4.77
OPA4684M	Quad, Low Power, CFB	5, ±5	1	210	160	—	820	-73	-77	3.7	3.5	35	1.7	120	CDIP	\$14.85
THS4011M	Low Noise, VFB	±5, ±15	1	290	50	100	310	-65	-80	7.5	6	6	7.8	110	CDIP, LCCC	\$13.16
THS4031M	100MHz, Low Noise, VFB	±5, ±15	1	275	100	220	100	-77	-67	1.6	2	6	8.5	90	CDIP, LCCC	\$13.16
THS4051M	70MHz, VFB	±5, ±15	1	70	38	50	240	-66	-79	14	10	6	8.5	100	CDIP, LCCC	\$13.16
THS4271/75-EP	Low Noise, VFB	5, ±5, 15	1	1400	390	400	1000	-100	-94	3	10	15	22	160	MSOP PowerPAD	\$7.16
THS4502/03-EP	Low Distortion, FDA	5, ±5	1	370	175	280	2800	-83	-97	6	7	4.6	23	120	MSOP PowerPAD	\$9.32

\*Suggested resale price in U.S. dollars in quantities of 1,000.

## ADC Selection Guide

Device	Res. (Bits)	Sample Rate (kSPS)	Architecture	No. of Input Channels	SINAD (dB)	SNR (dB)	SFDR (dB)	INL (%)	DNL (±LSB)	MIMC	V <sub>REF</sub>	Interface	No. of Supplies	Analog Supply	Logic Supply	Power (mW)	Price*	Refer to Page
<b>ADS1258</b>	24	125	Delta-Sigma	16 SE/8 Diff	—	—	—	0.0015	1	24	Ext	Serial	2	4.75, 5.25	1.8, 3.6	40	\$7.95	52, 54, 58
<b>ADS1271</b>	24	105	Delta-Sigma	1 Diff	—	109	108	0.0015	1	24	Ext	Serial, SPI w/FSYNC	2	4.75, 5.25	2.5, 3.6	35-100	\$5.90	53, 54
<b>ADS1274</b>	24	105	Delta-Sigma	4 Diff Simultaneous	—	109	108	0.001	1	24	Ext	Serial, SPI w/FSYNC	2	4.75, 5.25	2.5, 3.6	80-400	\$18.00	54
<b>ADS1252</b>	24	41	Delta-Sigma	1 SE/1 Diff	—	—	—	0.0015	1	24	Ext	Serial	1	4.75, 5.25	4.75, 5.25	40	\$5.60	54
<b>ADS1255</b>	24	30	Delta-Sigma	2 SE/1 Diff	—	—	—	0.001	1	24	Ext	Serial, SPI	2	4.75, 5.25	1.8, 3.6	35	\$6.50	54
<b>ADS1256</b>	24	30	Delta-Sigma	8 SE/4 Diff	—	—	—	0.001	1	24	Ext	Serial, SPI	2	4.75, 5.25	1.8, 3.6	35	\$6.95	54
<b>ADS1251</b>	24	20	Delta-Sigma	1 SE/1 Diff	—	—	—	0.0015	1	24	Ext	Serial	1	4.75, 5.25	4.75, 5.25	7.5	\$5.60	54
<b>ADS1253</b>	24	20	Delta-Sigma	4 SE/4 Diff	—	—	—	0.0015	1	24	Ext	Serial	1	4.75, 5.25	4.75, 5.25	7.5	\$6.70	54
<b>ADS1254</b>	24	20	Delta-Sigma	4 SE/4 Diff	—	—	—	0.0015	1	24	Ext	Serial	2	4.75, 5.25	1.8, 3.6	4	\$6.70	54
<b>ADS1210</b>	24	16	Delta-Sigma	1 SE/1 Diff	—	—	—	0.0015	1	24	Int/Ext	Serial, SPI	1	4.75, 5.25	4.75, 5.25	27.5	\$11.00	54
<b>ADS1211</b>	24	16	Delta-Sigma	4 SE/4 Diff	—	—	—	0.0015	1	24	Int/Ext	Serial, SPI	1	4.75, 5.25	4.75, 5.25	27.5	\$12.00	—
<b>ADS1201</b>	24	4	Modulator <sup>1</sup>	1 Diff	—	—	—	0.0015	1	24	Int/Ext	Bit-Stream	1	4.75, 5.25	4.75, 5.25	40	\$6.15	78
<b>ADS1216</b>	24	0.78	Delta-Sigma	8 SE/8 Diff	—	—	—	0.0015	1	24	Int/Ext	Serial, SPI	2	2.7, 5.25	2.7, 5.25	0.6	\$5.00	54
<b>ADS1217</b>	24	0.78	Delta-Sigma	8 SE/8 Diff	—	—	—	0.0015	1	24	Int/Ext	Serial, SPI	2	2.7, 5.25	2.7, 5.25	0.8	\$5.00	54
<b>ADS1218</b>	24	0.78	Delta-Sigma	8 SE/8 Diff	—	—	—	0.0015	1	24	Int/Ext	Serial, SPI	2	2.7, 5.25	2.7, 5.25	0.8	\$5.50	54
<b>ADS1222</b>	24	0.24	Delta-Sigma	2 SE/2 Diff	—	—	—	0.0015	1	24	Ext	Serial	2	2.7, 5.25	2.7, 5.25	0.5	\$2.95	54
<b>ADS1224</b>	24	0.24	Delta-Sigma	4 SE/4 Diff	—	—	—	0.0015	1	24	Ext	Serial	2	2.7, 5.25	2.7, 5.25	0.5	\$3.25	54
<b>ADS1225</b>	24	0.08	Delta-Sigma	1 Diff	—	—	—	0.0015	1	24	Ext	Serial	2	2.7, 5.25	2.7, 5.25	1.5	\$2.75	54
<b>ADS1226</b>	24	0.08	Delta-Sigma	2 Diff	—	—	—	0.0015	1	24	Ext	Serial	2	2.7, 5.25	2.7, 5.25	1.5	\$2.95	54
<b>ADS1232</b>	24	0.08	Delta-Sigma	2 SE/2 Diff	—	—	—	0.0015	1	24	Ext	Serial	2	2.7, 5.25	2.7, 5.25	3	\$3.90	52, 54
<b>ADS1234</b>	24	0.08	Delta-Sigma	4 SE/4 Diff	—	—	—	0.0015	1	24	Ext	Serial	2	2.7, 5.25	2.7, 5.25	3	\$4.50	52, 54
<b>ADS1244</b>	24	0.015	Delta-Sigma	1 SE/1 Diff	—	—	—	0.0008	1	24	Ext	Serial	2	2.5, 5.25	1.8, 3.6	0.3	\$2.95	54
<b>ADS1245</b>	24	0.015	Delta-Sigma	1 SE/1 Diff	—	—	—	0.0015	1	24	Ext	Serial	2	2.5, 5.25	1.8, 3.6	0.5	\$3.10	54
<b>ADS1240</b>	24	0.015	Delta-Sigma	4 SE/2 Diff	—	—	—	0.0015	1	24	Ext	Serial, SPI	2	2.7, 5.25	2.7, 5.25	0.6	\$3.80	54
<b>ADS1242</b>	24	0.015	Delta-Sigma	4 SE/2 Diff	—	—	—	0.0015	1	24	Ext	Serial, SPI	1	2.7, 5.25	2.7, 5.25	0.6	\$3.60	54
<b>ADS1241</b>	24	0.015	Delta-Sigma	8 SE/4 Diff	—	—	—	0.0015	1	24	Ext	Serial, SPI	2	2.7, 5.25	2.7, 5.25	0.5	\$4.20	54
<b>ADS1243</b>	24	0.015	Delta-Sigma	8 SE/4 Diff	—	—	—	0.0015	1	24	Ext	Serial, SPI	1	2.7, 5.25	2.7, 5.25	0.6	\$3.95	54
<b>ADS1212</b>	22	6.25	Delta-Sigma	1 SE/1 Diff	—	—	—	0.0015	1	22	Int/Ext	Serial, SPI	1	4.75, 5.25	4.75, 5.25	1.4	\$9.00	54
<b>ADS1213</b>	22	6.25	Delta-Sigma	4 SE/4 Diff	—	—	—	0.0015	1	22	Int/Ext	Serial, SPI	1	4.75, 5.25	4.75, 5.25	1.4	\$10.00	54
<b>ADS1250</b>	20	25	Delta-Sigma	1 SE/1 Diff	—	—	—	0.003	1	20	Ext	Serial, SPI	1	4.75, 5.25	4.75, 5.25	75	\$6.95	54
<b>DDC101</b>	20	15	Delta-Sigma	1 SE IIN	—	—	—	0.025	1	20	Ext	Serial	2	4.75, 5.25	4.75, 5.25	80	\$25.00	54
<b>DDC112</b>	20	3	Delta-Sigma	2 SE IIN	—	—	—	0.025	1	20	Ext	Serial	2	4.75, 5.25	4.75, 5.25	80	\$12.10	54
<b>DDC114</b>	20	3	Delta-Sigma	4 SE IIN	—	—	—	0.025	1	20	Ext	Serial	2	4.75, 5.0	2.7, 5.25	55	\$18.00	54
<b>DDC118</b>	20	3	Delta-Sigma	8 SE IIN	—	—	—	0.025	1	20	Ext	Serial	2	4.75, 5.0	2.7, 5.25	110	\$32.00	54
<b>DDC232</b>	20	3	Delta-Sigma	32 SE IIN	—	—	—	0.025	1	20	Ext	Serial	2	4.75, 5.0	2.7, 5.25	224-320	\$75.00	54, 85
<b>ADS1230</b>	20	0.08	Delta-Sigma	1 SE/1 Diff	—	—	—	0.003	1	20	Ext	Serial	2	2.7, 5.25	2.7, 5.25	3	\$2.50	54
<b>ADS1625</b>	18	1,250	Delta-Sigma	1 Diff	91	93	103	0.0015	1	18	Int/Ext	P18	2	4.75, 5.25	2.7, 5.25	520	\$24.95	54
<b>ADS1626</b>	18	1,250	Delta-Sigma	1 Diff	91	93	103	0.0015	1	18	Int/Ext	P18 w/FIFO	2	4.75, 5.25	4.75, 5.25	520	\$25.70	54
<b>ADS68482</b>	18	1,000	SAR	1 Diff	98	99	120	0.0011	1	18	Int/Ext	P8/P16/P18	2	4.75, 5.25	2.7, 5.25	220	\$20.25	59, 60
<b>ADS68481</b>	18	1,000	SAR	1 SE, 1 PDiff	93	94	112	0.0013	1	18	Int/Ext	P8/P16/P18	2	4.75, 5.25	2.7, 5.25	220	\$19.80	59, 60

<sup>1</sup>The Data Rate is dependent on clock divided by the Oversampling Ratio.

\*Suggested resale price in U.S. dollars in quantities of 1,000.

New products are listed in **bold red**.  
Preview products are listed in **bold blue**.



ADC Selection Guide (Continued)

Device	Res. (Bits)	Sample Rate (kSPS)	Architecture	No. of Input Channels	SINAD (dB)	SNR (dB)	SFDR (dB)	INL (%)	DNL (±LSB)	MMC	V <sub>REF</sub>	Interface	No. of Supplies	Analog Supply	Logic Supply	Power (mW)	Price*	Refer to Page
AD58382	18	600	SAR	1 Diff	95	96	112	0.0018	-1/+2	18	Int/Ext	Serial, SPI	1	4.75, 5.25	2.7, 5.75	100	\$16.95	60
AD58380	18	600	SAR	1 SE	90	91	112	0.0018	-1/+2	18	Int/Ext	Serial, SPI	1	4.75, 5.25	2.7, 5.75	100	\$16.50	60
AD58381	18	580	SAR	1 SE	88	88	112	0.0018	2.5	18	Ext	P8/P16/P18	2	4.75, 5.25	2.7, 5.25	100	\$16.65	60, 80
AD58383	18	500	SAR	1 SE	85	87	112	0.006	2.5	18	Ext	P8/P16/P18	2	4.75, 5.25	2.95, 5.25	110	\$15.75	60
AD51610	16	10,000	Delta-Sigma	1 Diff	83	84	96	0.005	0.5	16	Int/Ext	P16	2	4.75, 5.25	2.7, 5.25	1000	\$29.95	53, 54
AD51605	16	5,000	Delta-Sigma	1 Diff	86	88	101	0.0015	0.25	16	Int/Ext	P16	2	4.75, 5.25	2.7, 5.25	570	\$24.95	53, 54
AD51606	16	5,000	Delta-Sigma	1 Diff	86	88	101	0.0015	0.25	16	Int/Ext	P16 w/FIFO	2	4.75, 5.25	2.7, 5.25	570	\$25.70	54
AD58422	16	4,000	SAR	1 Diff	92	92	—	0.003	1	16	Int/Ext	P8/P16	2	4.75, 5.25	2.7, 5.25	160	\$23.95	60
AD51602	16	2,500	Delta-Sigma	1 Diff	86	88	101	0.0015	0.25	16	Int/Ext	Serial	2	4.75, 5.25	2.7, 5.25	550	\$19.95	54
AD58413	16	2,000	SAR	1 Diff	92	92	113	0.0038	1	16	Int/Ext	Serial, LVDS	2	4.75, 5.25	2.7, 5.25	290	\$24.05	60
AD58412	16	2,000	SAR	1 Diff	90	90	100	0.00375	2	16	Int	P8/P16	2	4.75, 5.25	2.95, 5.25	155	\$23.05	60
AD58411	16	2,000	SAR	1 SE	87	86	100	0.00375	2	16	Int	P8/P16	2	4.75, 5.25	2.95, 5.25	155	\$22.00	60
AD58410	16	2,000	SAR	1 SE, 1 PDiff	87.5	87	101	0.0038	1	16	Int/Ext	Serial, LVDS	2	4.75, 5.25	2.7, 5.25	290	\$23.00	60
AD58402	16	1,250	SAR	1 Diff	88	90	100	0.00375	2	16	Int	P8/P16	2	4.75, 5.25	2.95, 5.25	155	\$13.15	60
AD51601	16	1,250	Delta-Sigma	1 Diff	86	88	101	0.0015	0.25	16	Int/Ext	Serial	2	4.75, 5.25	2.7, 5.25	350	\$12.95	54
AD58406	16	1,250	SAR	1 Diff	90	91	105	0.003	-1, +1.5	16	Int/Ext	P8/P16	2	4.75, 5.25	2.7, 5.25	155	\$14.70	60
AD58401	16	1,250	SAR	1 SE	85	86	100	0.00375	2	16	Int	P8/P16	2	4.75, 5.25	2.95, 5.25	155	\$12.55	60
AD58405	16	1,250	SAR	1 SE, 1 PDiff	85	86	105	0.003	-1, +1.5	16	Int/Ext	P8/P16	2	4.75, 5.25	2.7, 5.25	155	\$14.10	60
AD58329	16	1,000	SAR	1 SE, 1 PDiff	85	86	94	0.0045	—	16	Ext	Serial, SPI	2	2.7, 5.5	1.65, 5.5	20	\$11.25	60
AD58330	16	1,000	SAR	2 SE, 2 PDiff	85	86	94	0.0045	—	16	Ext	Serial, SPI	2	2.7, 5.5	1.65, 5.5	20	\$12.00	60
AD58371	16	750	SAR	1 SE	87	87	100	0.0022	2	16	Ext	P8/P16	2	4.75, 5.25	2.95, 5.25	110	\$12.00	60
AD58372	16	600	SAR	1 Diff	94	94	109	0.0012	1	16	Int/Ext	Serial, SPI	2	4.75, 5.25	2.7, 5.25	110	\$13.00	58, 60
AD58370	16	600	SAR	1 SE, 1 PDiff	90	90	109	0.0015	-1, +1.5	16	Int/Ext	Serial, SPI	2	4.75, 5.25	2.7, 5.25	110	\$12.50	58, 60
AD58322	16	500	SAR	1 Diff	83	—	96	0.009	2	15	Int/Ext	P8/P16	1	4.75, 5.25	4.75, 5.25	85	\$7.10	60
AD58323	16	500	SAR	1 Diff	83	—	94	0.009	2	15	Int/Ext	P8/P16	1	4.75, 5.25	4.75, 5.25	85	\$7.10	60
AD58327	16	500	SAR	1 SE, 1 PDiff	85	86	94	0.00305	—	16	Ext	Serial, SPI	2	2.7, 5.5	1.65, 5.5	10.6	\$8.50	59, 60
AD58328	16	500	SAR	2 SE, 2 PDiff	85	86	94	0.00305	—	16	Ext	Serial, SPI	2	2.7, 5.5	1.65, 5.5	10.6	\$9.30	59, 60
AD58361	16	500	SAR	2 x 2 Diff	83	83	94	0.00375	1.5	14	Int/Ext	Serial, SPI	2	4.75, 5.25	2.7, 5.5	150	\$8.75	26, 60, 78
AD58509	16	250	SAR	1 SE	86	88	100	0.005	1	16	Int/Ext	Serial, SPI	1	4.75, 5.25	4.75, 5.25	70	\$12.95	58, 60
AD58505	16	250	SAR	1 SE	86	88	100	0.005	1	16	Int/Ext	P8/P16	1	4.75, 5.25	4.75, 5.25	70	\$12.95	58, 60
AD57811	16	250	SAR	1 SE	87	87	100	0.006	2	15	Int/Ext	P16	2	4.75, 5.25	4.75, 5.25	200	\$36.15	60
AD57815	16	250	SAR	1 SE	84	84	100	0.006	2	15	Int/Ext	P16	2	4.75, 5.25	4.75, 5.25	200	\$21.30	60
AD58365	16	250	SAR	1 x 6 Diff	87	87	94	0.006	1.5	15	Int/Ext	P16	1	4.75, 5.25	4.75, 5.25	200	\$17.00	60, 78
AD58364	16	250	SAR	1 x 6 Diff	82.5	83	94	0.009	3	14	Int/Ext	P16	1	4.75, 5.25	4.75, 5.25	413	\$18.10	60, 78
AD58342	16	250	SAR	4 Diff	85	87	92	0.006	2	16	Ext	P8/P16	2	4.75, 5.25	2.7, 5.5	200	\$11.30	60
TLC4545	16	200	SAR	1 Diff	84.5	85	95	0.0045	2	16	Ext	Serial, SPI	1	4.5, 5.5	4.5, 5.5	17.5	\$6.85	60
TLC4541	16	200	SAR	1 SE	84.5	85	95	0.0045	2	16	Ext	Serial, SPI	1	4.5, 5.5	4.5, 5.5	17.5	\$6.85	60
AD58320	16	100	SAR	1 Diff	84	92	86	0.012	2	15	Ext	Serial, SPI	1	2.7, 5.25	2.7, 5.25	1.95	\$5.15	60
AD58321	16	100	SAR	1 Diff	84	87	86	0.012	2	15	Ext	Serial, SPI	1	4.75, 5.25	4.75, 5.25	5.5	\$5.15	60

\*Suggested resale price in U.S. dollars in quantities of 1,000.  
New products are listed in bold red.  
Preview products are listed in bold blue.

Device	Res. (Bits)	Sample Rate (kSPS)	Architecture	No. of Input Channels	SINAD (dB)	SNR (dB)	SFDR (dB)	INL (%)	DNL (±LSB)	NIMC	V <sub>REF</sub>	Interface	No. of Supplies	Analog Supply	Logic Supply	Power (mW)	Price*	Refer to Page
ADS8326	16	100	SAR	1 Diff	91	91	108	0.006	2	16	Ext	Serial, SPI	1	2.7, 5.25	2.7, 5.25	2.25	\$5.90	60
ADS7805	16	100	SAR	1 SE	86	86	94	0.0045	1	16	Int/Ext	P8/P16	1	4.75, 5.25	4.75, 5.25	81.5	\$21.80	60
ADS7809	16	100	SAR	1 SE	88	88	100	0.0045	1	16	Int/Ext	Serial, SPI	1	4.75, 5.25	4.75, 5.25	81.5	\$21.80	60
ADS8341	16	100	SAR	4 SE 2 Diff	86	—	92	0.006	2	15	Ext	Serial, SPI	1	2.7, 5.25	2.7, 5.25	3.6	\$7.40	60
ADS8343	16	100	SAR	4 SE 2 Diff	86	—	97	0.006	2	15	Ext	Serial, SPI	1	2.7, 5.25	2.7, 5.25	3.6	\$7.45	60
ADS8344	16	100	SAR	8 SE 4 Diff	86	—	92	0.006	2	15	Ext	Serial, SPI	1	2.7, 5.25	2.7, 5.25	3.6	\$8.00	60
ADS8345	16	100	SAR	8 SE 4 Diff	85	—	98	0.006	2	15	Ext	Serial, SPI	1	2.7, 5.25	2.7, 5.25	3.6	\$8.00	60
ADS7807	16	40	SAR	1 SE	88	88	100	0.0022	1.5	16	Int/Ext	Serial, SPI/P8	1	4.75, 5.25	4.75, 5.25	28	\$27.40	60
ADS7813	16	40	SAR	1 SE	89	89	102	0.003	1	16	Int/Ext	Serial, SPI	1	4.75, 5.25	4.75, 5.25	35	\$21.30	60
ADS1202	16	40	Modulator <sup>1</sup>	1 SE 1 Diff	—	—	—	0.018	1	16	Int/Ext	Bit Stream	1	4.75, 5.25	4.75, 5.25	30	\$2.50	76-79
ADS1203	16	40	Modulator <sup>1</sup>	1 SE 1 Diff	—	—	—	0.003	1	16	Int/Ext	Bit Stream	1	4.75, 5.25	4.75, 5.25	30	\$2.70	76-79
ADS1204	16	40	Modulator <sup>1</sup>	4 SE 4 Diff	—	—	—	0.003	1	16	Int/Ext	Bit Stream	1	4.75, 5.25	4.75, 5.25	60	\$6.75	76-79
ADS1205	16	40	Modulator <sup>1</sup>	2	88.2	88.9	98	0.005	1	16	Int/Ext	Bit Stream	1	4.5, 5.5	2.7, 5.5	75	\$3.95	76, 78, 79
ADS1208	16	40	Modulator <sup>1</sup>	1 SE 1 Diff	81.5	82	93	0.012	1	16	Int/Ext	Bit Stream	2	4.5, 5.5	2.7, 5.5	64	\$2.95	76, 78, 79
ADS7825	16	40	SAR	4 SE	83	86	90	0.003	1	16	Int/Ext	Serial, SPI/P8	1	4.75, 5.25	4.75, 5.25	50	\$29.55	60
ADS1204	16	40	Modulator <sup>1</sup>	4 SE 4 Diff	—	—	—	0.003	1	16	Int/Ext	Bit Stream	1	4.75, 5.25	4.75, 5.25	60	\$6.75	76, 78, 79
ADS1110	16	0.24	Delta-Sigma	1 SE 1 Diff	—	—	—	0.01	1	16	Int	Serial, I <sup>2</sup> C	1	2.7, 5.5	2.7, 5.5	0.7	\$1.95	54
ADS1112	16	0.24	Delta-Sigma	3 SE 2 Diff	—	—	—	0.01	1	16	Int	Serial, I <sup>2</sup> C	1	2.7, 5.5	2.7, 5.5	0.7	\$2.65	54
ADS1100	16	0.128	Delta-Sigma	1 SE 1 Diff	—	—	—	0.0125	1	16	Ext	Serial, I <sup>2</sup> C	1	2.7, 5.5	2.7, 5.5	0.3	\$1.80	54
ADS5500	14	125,000	Pipeline	1 Diff	70	70.5	82	5LSB	-0.9/+1.1	14	Int	P14	1	3.0, 3.6	3.0, 3.6	780	\$95.00	66, 85
ADS5500-EP	14	125,000	Pipeline	1 Diff	70	70.5	82	5LSB	-0.9/+1.1	14	Int	P14	1	3.0, 3.6	3.0, 3.6	780	\$190.00	85
ADS5541	14	105,000	Pipeline	1 Diff	—	71	82	—	—	14	Int	P14	1	3.0, 3.6	3.3	710	\$75.00	66
ADS5424	14	105,000	Pipeline	1 Diff	74	74	93	1.5LSB	-0.95, 1.5	14	Int	P14	1	4.25, 5.25	3, 3.6	1900	\$66.00	64, 66
ADS542	14	80,000	Pipeline	1 Diff	—	72	85	—	—	14	Int	P14	1	3.0, 3.6	3.3	670	\$30.00	66
ADS5523	14	80,000	Pipeline	1 Diff	74	74	94	1.5LSB	-0.95, 1.5	14	Int	P14	1	4.75, 5.25	3, 3.6	1850	\$40.00	64, 68
ADS5433	14	80,000	Pipeline	1 Diff	74	74	96.5	1.5LSB	-0.95, 1.5	14	Int	P14	1	4.75, 5.25	3, 3.6	1850	\$48.00	64, 66
ADS5553	14	65,000	Pipeline	2 Diff	73.4	74	84	2.5LSB	0.6	14	Int	P14	1	3, 3.6	3, 3.6	890	\$30.00	66
ADS5422	14	62,000	Pipeline	1 Diff	72	72	85	—	1	14	Int/Ext	P14	2	4.75, 5.25	3, 5	1200	\$30.45	66
ADS5421	14	40,000	Pipeline	1 Diff	75	75	83	—	1	14	Int/Ext	P14	2	4.75, 5.25	3, 5	900	\$20.15	66
ADS860	14	10,000	Pipeline	1 SE 1 Diff	75	76	85	5LSB	1	14	Int/Ext	P14	2	4.7, 5.3	2.7, 5.3	250	\$16.80	66
THS1408	14	8,000	Pipeline	1 SE 1 Diff	70	72	80	5LSB	1	—	Int/Ext	P14	1	3, 3.6	3, 3.6	270	\$14.85	66, 85
THS1408-EP	14	8,000	Pipeline	1 SE 1 Diff	70	72	80	5LSB	1	—	Int/Ext	P14	1	3, 3.6	3, 3.6	270	\$18.09	85
ADS7891	14	3,000	SAR	1 SE	78	77.5	88	0.009	+1.5/-1	14	Int	P8/P14	2	4.75, 5.25	2.7, 5.25	90	\$10.50	60
THS1403	14	3,000	Pipeline	1 SE 1 Diff	70	72	80	5LSB	1	—	Int/Ext	P14	1	3, 3.6	3, 3.6	270	\$11.05	66, 85
THS14F03	14	3,000	Pipeline	1 SE 1 Diff	70	72	80	2.5LSB	1	—	Int/Ext	P14	1	3, 3.6	3, 3.6	270	\$12.60	66
THS1403-EP	14	3,000	Pipeline	1 SE 1 Diff	70	72	80	5LSB	1	—	Int/Ext	P14	1	3, 3.6	3, 3.6	270	\$25.39	85
ADS7890	14	1,250	SAR	1 SE	78	77.5	100	0.009	+1.5/-1	14	Int	Serial, SPI	2	4.75, 5.25	2.7, 5.25	90	\$10.50	60
THS1401	14	1,000	Pipeline	1 SE 1 Diff	70	72	80	5LSB	1	—	Int/Ext	P14	1	3, 3.6	3, 3.6	270	\$11.05	66, 85
THS14F01	14	1,000	Pipeline	1 SE 1 Diff	70	72	80	2.5LSB	1	—	Int/Ext	P14	1	3, 3.6	3, 3.6	270	\$12.60	66
THS1401-EP	14	1,000	Pipeline	1 SE 1 Diff	70	72	80	5LSB	1	—	Int/Ext	P14	1	3, 3.6	3, 3.6	270	\$25.39	85
TLC3545	14	200	SAR	1 Diff	81.5	82	95	0.006	1	14	Ext	Serial, SPI	1	4.5, 5.5	4.5, 5.5	17.5	\$5.00	60

<sup>1</sup>The Data Rate is dependent on clock divided by the Oversampling Ratio. \*Suggested resale price in U.S. dollars in quantities of 1,000.

New products are listed in **bold red**. Preview products are listed in **bold blue**.

ADC Selection Guide (Continued)

Device	Res. (Bits)	Sample Rate (kSPS)	Architecture	No. of Input Channels	SINAD (dB)	SNR (dB)	SFDR (dB)	INL (%)	DNL ( $\pm$ LSB)	NIMC	V <sub>REF</sub>	Interface	No. of Supplies	Analog Supply	Logic Supply	Power (mW)	Price*	Refer to Page
TLCS341	14	200	SAR	1 SE	81.5	82	95	0.006	1	14	Ext	Serial, SPI	1	4.5, 5.5	4.5, 5.5	17.5	\$5.00	60
TLCS374	14	200	SAR	4 SE	79	80	84	0.006	1	14	Ext	Serial, SPI	2	4.5, 5.5	2.7, 5.5	29	\$6.85	60
TLCS344	14	200	SAR	4 SE/2 Diff	81	81	97	0.006	1	14	Int/Ext	Serial, SPI	2	4.5, 5.5	2.7, 5.5	20	\$6.00	61
TLCS378	14	200	SAR	8 SE	79	80	83	0.006	1	14	Ext	Serial, SPI	2	4.5, 5.5	2.7, 5.5	29	\$8.65	61
TLCS348	14	200	SAR	8 SE/4 Diff	81	81	97	0.006	1	14	Int/Ext	Serial, SPI	2	4.5, 5.5	2.7, 5.5	20	\$6.40	61
ADS5E46	14	190	Pipeline	1 Diff	72.5	73.2	84	—	—	14	Int/Ext	P14 & LVDS	1	3, 3.6	3, 3.6	1130	\$72.50	65, 66
ADS5E45	14	170	Pipeline	1 Diff	—	73.5	85	—	—	14	Int/Ext	P14 & LVDS	1	3, 3.6	3, 3.6	1100	\$62.50	66, 66
ADS3824	14	50	SAR	1 Diff	78	78	85	0.012	2	14	Ext	Serial, SPI	1	1.8, 3.6	1.8, 3.6	2.5	\$4.15	61
ADS7871	14	40	MUX SAR, PGA	1 Diff	—	—	—	0.03	2	13	Int	Serial, SPI	1	2.7, 5.25	2.7, 5.25	6	\$5.00	61, 78
TL7135	14	0.003	Dual-Slope	8 SE/4 Diff	—	—	—	0.005	—	4.5Dig	Ext	MUX BCD	2	4.75, 5.25	4.75, 5.25	5	\$1.95	54
ADS5444	13	250	Pipeline	1 SE/1 Diff	66.2	68.7	71	—	—	13	Int	LVDS	2	4.75, 5.25	3, 3.6	2100	\$95.00	64, 66
ADS5440	13	210	Pipeline	1 SE/1 Diff	68	69	76	2.2LSB	1	13	Int	LVDS	2	4.75, 5.25	3, 3.6	2100	\$65.00	64, 66
ADS5E20	12	125,000	Pipeline	1 Diff	—	—	82	—	—	12	Int	P12	1	3.0, 3.6	3.3	740	\$33.90	66
ADS5E21	12	105,000	Pipeline	1 Diff	—	—	85	—	—	12	Int	P12	1	3.0, 3.6	3.3	700	\$29.90	66
ADS5E22	12	80,000	Pipeline	1 Diff	—	70	82	—	—	12	Int	P12	1	3.0, 3.6	3.3	660	\$16.70	66
ADS909	12	80,000	Pipeline	1 SE/1 Diff	64	63	67	6LSB	1.7	12	Int/Ext	P12	2	4.75, 5.25	3, 5	905	\$24.95	66
ADS9410	12	80,000	Pipeline	1 SE/1 Diff	66	65	76	2LSB	1	14	Int/Ext	P12	2	3, 3.6	1.6, 2	360	\$19.00	66
ADS908	12	70,000	Pipeline	1 SE/1 Diff	64	64	68	7LSB	1.7	12	Int/Ext	P12	2	4.75, 5.25	3, 5	720	\$19.50	66
ADS5Z73	12	70,000	Pipeline	8 Diff	70.8	71	90	$\pm$ 3LSB	+1/2-0.99	12	Int/Ext	LVDS	1	3.0, 3.6	3.3	1003	\$121.00	66
ADS9413	12	65,000	Pipeline	1 Diff	67.6	68.5	77.5	2LSB	1	12	Int/Ext	P12	1	3.0, 3.6	3.3	400	\$15.50	66
ADS5Z21	12	65,000	Pipeline	1 SE/1 Diff	69	70	90	$\pm$ 1.5LSB	1	12	Int/Ext	P12	1	3.0, 3.6	2.5, 3.3	285	\$13.95	66
ADS5Z32	12	65,000	Pipeline	2 Diff	69	69.5	85	$\pm$ 2.5LSB	0.9	12	Int/Ext	P12	1	3, 3.6	3, 3.6	340	\$18.15	66
ADS5Z42	12	65,000	Pipeline	4 Diff	70.8	71	85	2.5LSB	+1/-0.95	12	Int/Ext	LVDS	1	3.0, 3.6	3.3	660	\$30.00	66
ADS5Z72	12	65,000	Pipeline	8 Diff	71	71.1	89	2.5LSB	+1/-0.95	12	Int/Ext	LVDS	1	3.0, 3.6	3.3	984	\$44.85	66
ADS907	12	53,000	Pipeline	1 SE/1 Diff	69	69	82	4LSB	1	12	Int/Ext	P12	2	4.75, 5.25	3, 5	335	\$11.30	66
ADS2807	12	50,000	Pipeline	2 SE/2 Diff	68	65	70	5LSB	1	12	Int/Ext	P12	2	4.75, 5.25	3, 5	720	\$18.05	66
ADS5Z71	12	50,000	Pipeline	8 Diff	70	70.5	85	$\pm$ 2LSB	0.9	12	Int/Ext	LVDS	1	3.0, 3.6	3.3	927	\$48.00	66
ADS5Z20	12	40,000	Pipeline	1 SE/1 Diff	69	70	90	1.5	1	12	Int/Ext	P12	1	3.0, 3.6	2.5, 3.3	195	\$9.85	66
ADS900	12	40,000	Pipeline	1 SE/1 Diff	64	62	61	—	1	12	Int/Ext	P12	1	4.75, 5.25	4.75, 5.25	390	\$30.85	66
ADS5Z40	12	40,000	Pipeline	4 Diff	70	70.5	85	2	0.9	12	Int/Ext	LVDS	1	3.0, 3.6	3.3	584	\$20.00	66
ADS5Z70	12	40,000	Pipeline	8 Diff	70	70.5	87	2	0.9	12	Int/Ext	LVDS	1	3.0, 3.6	3.3	888	\$44.00	66
ADS2806	12	32,000	Pipeline	2 SE/2 Diff	69	66	73	4LSB	1	12	Int/Ext	P12	2	4.75, 5.25	3, 5	430	\$14.10	66
THS1230	12	30,000	Pipeline	1 SE/1 Diff	67.4	67.7	74.6	2.5LSB	1	12	Int/Ext	P12	1	3, 3.6	3, 3.6	168	\$10.50	66
ADS801	12	25,000	Pipeline	1 SE/1 Diff	66	64	61	—	1	12	Int/Ext	P12	1	4.75, 5.25	4.75, 5.25	270	\$12.55	66
ADS905	12	20,000	Pipeline	1 SE/1 Diff	66	68	74	2LSB	0.75	12	Int/Ext	P12	1	4.75, 5.25	4.75, 5.25	300	\$9.90	66
THS1215	12	15,000	Pipeline	1 SE/1 Diff	68.6	68.9	81.7	1.5LSB	0.9	12	Int/Ext	P12	1	3, 3.6	3, 3.6	148	\$9.85	66
THS1215	12	15,000	Pipeline	1 SE/1 Diff	68.6	68.9	81.7	1.5LSB	0.9	12	Int/Ext	P12	1	3, 3.6	3, 3.6	148	\$9.85	66

\*Suggested resale price in U.S. dollars in quantities of 1,000.  
New products are listed in bold red.  
Preview products are listed in bold blue.

## ADC Selection Guide (Continued)

Device	Res. (Bits)	Sample Rate (kSPS)	Architecture	No. of Input Channels	SINAD (dB)	SNR (dB)	SFDR (dB)	INL (%)	DNL (±LSB)	NMC	V <sub>REF</sub>	Interface	No. of Supplies	Analog Supply	Logic Supply	Power (mW)	Price*	Refer to Page
ADS802	12	10,000	Pipeline	1 SE/1 Diff	66	66	66	2.75LSB	1	12	Int/Ext	P12	1	4.75, 5.25	4.75, 5.25	260	\$12.60	66
ADS804	12	10,000	Pipeline	1 SE/1 Diff	68	69	80	2LSB	0.75	12	Int/Ext	P12	2	4.7, 5.3	3, 5	180	\$9.20	66
THS12082	12	8,000	Pipeline	2 SE/1 Diff	65	69	71	1.5LSB	1	12	Int/Ext	P12	2	4.75, 5.25	3, 5.25	186	\$8.40	66
THS1209	12	8,000	Pipeline	2 SE/1 Diff	65	69	71	1.5LSB	1	12	Int/Ext	P12	2	4.75, 5.25	4.75, 5.25	186	\$7.90	66
THS1206	12	6,000	Pipeline	4 SE/2 Diff	65	69	71	1.8LSB	1	12	Int/Ext	P12	2	4.75, 5.25	3, 5.25	186	\$7.80	66, 85
THS1207	12	6,000	Pipeline	4 SE/2 Diff	64	69	71	1.5LSB	1	12	Int/Ext	P12	2	4.75, 5.25	4.75, 5.25	186	\$7.25	66
THS1206-EP	12	6,000	Pipeline	4 SE/2 Diff	65	69	71	1.8LSB	1	12	Int/Ext	P12	2	4.75, 5.25	3, 5.25	186	\$17.61	85
ADS803	12	5,000	Pipeline	1 SE/1 Diff	68	69	82	0.75LSB	2	12	Int/Ext	P12	2	4.7, 5.3	4.7, 5.3	115	\$7.03	67
ADS1881	12	4,000	SAR	1 SE	71.5	71.5	90	0.024	1	12	Int	P8/P12	2	4.75, 5.25	2.7, 5.25	110	\$7.35	61
<b>ADS1886</b>	12	1,000	SAR	1 SE	71.2	71.5	85.5	0.024	±4	12	Ext	Serial, SPI	1	2.5, 5.75	2.5, 5.75	11	\$1.70	61, 90
<b>ADS1869</b>	12	1,000	SAR	12 Diff	—	—	—	0.048	2	11	Int/Ext	Serial, SPI, P12	3	3.3, 5.5	2.7, 5.5	175	\$14.60	61, 76, 78
ADS1810	12	800	SAR	1 SE	71	71	82	0.018	1	12	Int/Ext	P12	2	4.75, 5.25	4.75, 5.25	225	\$27.80	61
ADS1818	12	500	SAR	1 Diff	70	72	78	0.024	1	12	Int	Serial, SPI	1	4.75, 5.25	4.75, 5.25	11	\$2.50	61
ADS1834	12	500	SAR	1 Diff	70	72	78	0.024	1	12	Int	Serial, SPI	1	4.75, 5.25	4.75, 5.25	11	\$2.45	61
ADS1835	12	500	SAR	1 Diff	72	72	78	0.024	1	12	Int	Serial, SPI	1	4.75, 5.25	4.75, 5.25	17.5	\$2.75	61
ADS1861	12	500	SAR	2 x 2 Diff	70	71	72	0.024	1	12	Int/Ext	Serial, SPI	1	4.75, 5.25	4.75, 5.25	25	\$4.05	61, 78
ADS1862	12	500	SAR	2 x 2 Diff	71	71	78	0.024	1	12	Int/Ext	P12	1	4.75, 5.25	4.75, 5.25	25	\$5.70	61, 78
ADS1864	12	500	SAR	3 x 2 Diff	71	71	78	0.024	1	12	Int/Ext	P12	1	4.75, 5.25	4.75, 5.25	52.5	\$6.65	61, 78
ADS1862	12	500	SAR	8 SE	72	72	74	0.024	1	12	Int/Ext	P12	1	4.75, 5.25	4.75, 5.25	13	\$3.40	61
TL2355	12	400	SAR	1 Diff	72	—	84	0.024	1	12	Int	Serial, SPI	1	4.5, 5.5	4.5, 5.5	15	\$3.95	61
TL2351	12	400	SAR	1 SE	72	—	84	0.024	1	12	Ext	Serial, SPI	1	4.5, 5.5	4.5, 5.5	15	\$3.95	61
TL2352	12	400	SAR	2 SE	72	—	84	0.024	1	12	Ext	Serial, SPI	1	4.5, 5.5	4.5, 5.5	15	\$3.95	61
TL2354	12	400	SAR	4 SE	71	—	84	0.024	1	12	Int/Ext	Serial, SPI	1	4.5, 5.5	4.5, 5.5	9.5	\$5.30	61
TL2358	12	400	SAR	8 SE	71	—	84	0.024	1	12	Int/Ext	Serial, SPI	1	4.5, 5.5	4.5, 5.5	9.5	\$5.30	61
ADS1800	12	333	SAR	1 SE	72	71	77	0.012	0.75	12	Int	P8/P12	3	4.75, 5.25	4.75, 5.25	135	\$30.50	61
<b>ADS8504</b>	12	250	SAR	1 SE	72	70	80	0.011	0.45	12	Int/Ext	P8/P12	1	4.75, 5.25	4.75, 5.25	70	\$10.50	58, 61
<b>ADS8508</b>	12	250	SAR	1 SE	73	73	90	0.011	0.45	12	Int/Ext	Serial, SPI	1	4.75, 5.25	4.75, 5.25	70	\$10.50	58, 61
ADS1816	12	200	SAR	1 Diff	72	72	86	0.024	0.75	12	Ext	Serial, SPI	1	4.5, 5.25	4.75, 5.25	1.9	\$1.95	61
ADS1817	12	200	SAR	1 Diff	71	71	86	0.024	1	12	Ext	Serial, SPI	1	4.75, 5.25	4.75, 5.25	2.3	\$1.95	61
TL2545	12	200	SAR	1 Diff	72	—	84	0.024	1	12	Ext	Serial, SPI	1	2.7, 5.5	2.7, 5.5	2.8	\$3.85	61
<b>ADS1866</b>	12	200	SAR	1 SE	70	71	—	0.024	±1	12	Ext	Serial, SPI	1	1.2, 3.6	1.2, 3.6	0.25	\$1.85	61
TL2541	12	200	SAR	1 SE	72	—	84	0.024	1	12	Ext	Serial, SPI	1	2.7, 5.5	2.7, 5.5	2.8	\$3.85	61
TL2553	12	200	SAR	11 SE	—	—	—	0.024	1	12	Ext	Serial, SPI	1	2.7, 5.5	2.7, 5.5	2.43	\$3.40	61
TL2556	12	200	SAR	11 SE	—	—	—	0.024	1	12	Int/Ext	Serial, SPI	1	2.7, 5.5	2.7, 5.5	2.43	\$3.55	61
<b>AMC1823</b>	12	200	SAR, DAS	1x8 SE I/O	—	74	—	0.024	1	12	Int/Ext	Serial, SPI	2	2.7, 5.5	2.7, 5.5	100	\$9.75	61, 76, 78
TL2542	12	200	SAR	2 SE	72	—	84	0.024	1	12	Ext	Serial, SPI	1	2.7, 5.5	2.7, 5.5	2.8	\$3.85	61
ADS1842	12	200	SAR	4 SE	72	72	79	0.024	1	12	Ext	P12	1	2.7, 5.25	2.7, 5.25	0.84	\$3.10	61
TL2574	12	200	SAR	4 SE	79	80	84	0.024	0.5	12	Ext	Serial, SPI	2	4.75, 5.5	2.7, 5.5	29	\$5.30	61
TL2544	12	200	SAR	4 SE	70	—	84	0.024	1	12	Int/Ext	Serial, SPI	1	2.7, 5.5	2.7, 5.5	3.3	\$4.20	61

\*Suggested resale price in U.S. dollars in quantities of 1,000.

New products are listed in bold red.

ADC Selection Guide (Continued)

Device	Res. (Bits)	Sample Rate (kSPS)	Architecture	No. of Input Channels	SINAD (dB)	SNR (dB)	SFDR (dB)	INL (%)	DNL (±LSB)	NIMC	V <sub>REF</sub>	Interface	No. of Supplies	Analog Supply	Logic Supply	Power (mW)	Price*	Refer to Page
ADS7841	12	200	SAR	4 SE/2 Diff	72	72	79	0.024	1	12	Ext	Serial, SPI	1	2.7, 5.25	2.7, 5.25	0.84	\$2.50	61
TLC2578	12	200	SAR	8 SE	79	80	84	0.024	0.5	12	Ext	Serial, SPI	2	4.75, 5.5	2.7, 5.5	29	\$5.80	61
TLV2548	12	200	SAR	8 SE	70	—	84	0.024	1	12	Int/Ext	Serial, SPI	1	2.7, 5.5	2.7, 5.5	3.3	\$4.85	61, 85
TLV2548M	12	200	SAR	8 SE	71	—	75	1.2LSB	1	12	Int/Ext	Serial, SPI	1	2.7, 5.5	2.7, 5.5	3.3	\$151.89	85
ADS7844	12	200	SAR	8 SE/4 Diff	72	72	78	0.024	1	12	Ext	Serial, SPI	1	2.7, 5.25	2.7, 5.25	0.84	\$2.90	61
ADS7822	12	200	SAR	1 Diff	71	—	86	0.018	0.75	12	Ext	Serial, SPI	1	2.7, 5.25	2.7, 5.25	0.6	\$1.55	61
ADS7829	12	125	SAR	1 Diff	71	—	86	0.018	0.75	12	Ext	Serial, SPI	1	2.7, 5.25	2.7, 5.25	0.6	\$1.50	61
ADS7804	12	100	SAR	1 SE	72	70	80	0.011	0.45	12	Int/Ext	P8/P12	1	4.75, 5.25	4.75, 5.25	81.5	\$14.05	61
ADS7808	12	100	SAR	1 SE	73	73	90	0.011	0.45	12	Int/Ext	Serial, SPI	1	4.75, 5.25	4.75, 5.25	81.5	\$10.85	61
AMC7820	12	100	SAR, PGA	1x8 SE I/O	72	—	—	0.024	1	12	Int	Serial, SPI	2	4.75, 5.25	2.7, 5.25	40	\$3.75	61, 78
TLC2543	12	66	SAR	11 SE	—	—	—	0.024	1	12	Ext	Serial, SPI	1	4.5, 5.5	4.5, 5.5	5	\$4.45	61, 85
TLV2543	12	66	SAR	11 SE	—	—	—	0.024	1	12	Ext	Serial, SPI	1	3.3, 3.6	3.3, 3.6	3.3	\$4.45	61
TLC2543-EP	12	66	SAR	11 SE	—	—	—	0.024	1	12	Ext	Serial, SPI	1	4.5, 5.5	4.5, 5.5	5	\$9.85	61, 85
ADS7823	12	50	SAR	1 SE	71	72	86	0.024	1	12	Ext	Serial, I <sup>2</sup> C	1	2.7, 5.25	2.7, 5.25	0.75	\$2.85	61
ADS7870	12	50	MUX SAR, PGA	8 SE	72	—	—	0.06	—	12	Int	Serial, SPI	1	2.7, 5.25	2.7, 5.25	4.6	\$4.15	61, 78
ADS7828	12	50	SAR	8 SE/4 Diff	71	72	86	0.024	1	12	Int/Ext	Serial, I <sup>2</sup> C	1	2.7, 5.25	2.7, 5.25	0.675	\$3.35	61
ADS7806	12	40	SAR	1 SE	73	73	90	0.011	0.45	12	Int/Ext	Serial, SPI/P8	1	4.75, 5.25	4.75, 5.25	28	\$12.75	61
ADS7812	12	40	SAR	1 SE	74	74	98	0.012	0.5	12	Int/Ext	Serial, SPI	1	4.75, 5.25	4.75, 5.25	35	\$11.80	62
ADS7824	12	40	SAR	4 SE	73	73	90	0.012	0.5	12	Int/Ext	Serial, SPI/P8	1	4.75, 5.25	4.75, 5.25	50	\$13.10	62
ADS1286	12	37	SAR	1 Diff	72	—	90	0.024	0.75	12	Ext	Serial, SPI	1	4.75, 5.25	4.75, 5.25	1	\$2.80	62
<b>ADS1010</b>	12	0.25	Delta-Sigma	1 SE/1 Diff	—	—	—	0.001	1	12	Int	Serial, I <sup>2</sup> C	1	4.75, 5.25	4.75, 5.25	0.7	\$1.10	54
<b>ADS1012</b>	12	0.24	Delta-Sigma	3 SE/1 Diff	—	—	—	0.001	1	12	Int	Serial, I <sup>2</sup> C	1	4.75, 5.25	4.75, 5.25	0.7	\$1.45	54
<b>ADS1000</b>	12	0.128	Delta-Sigma	1 SE/1 Diff	—	—	—	0.001	1	12	Ext	Serial, I <sup>2</sup> C	1	4.75, 5.25	4.75, 5.25	0.3	\$0.99	54
ADS5413-11	11	65,000	Pipeline	1 Diff	65	65	77	1LSB	0.75	11	Int/Ext	Serial	2	3, 3.6	1.6, 2	400	\$14.75	67
ADS828	10	75,000	Pipeline	1 SE/1 Diff	57	57	68	3LSB	1	10	Int/Ext	P10	2	4.75, 5.25	3, 5	340	\$8.70	67
ADS5102	10	65,000	Pipeline	1 Diff	58	57	71	2.5LSB	1	10	Int/Ext	P10	1	1.65, 2	1.65, 2	160	\$7.10	67
<b>ADS5277</b>	10	65,000	Pipeline	8 Diff	61.7	61.7	80	2.0LSB	0.9	10	Int/Ext	P10	1	3.0, 3.6	3.3	911	\$40.00	67
ADS5122	10	65,000	Pipeline	8 Diff	58	59	72	2.5LSB	1	10	Int/Ext	P10	2	1.65, 2.0	1.65, 3.6	733	\$42.85	67
ADS526/823	10	60,000	Pipeline	1 SE/1 Diff	58	59/60	73	2LSB	1	10	Int/Ext	P10	2	4.75, 5.25	3, 5	295	\$8.40	67
ADS5103	10	40,000	Pipeline	1 Diff	58	58	66	1.5LSB	0.8	10	Int/Ext	P10	1	1.65, 2	1.65, 2	105	\$5.25	67
ADS822/825	10	40,000	Pipeline	1 SE/1 Diff	59	60	65	2LSB	1	10	Int/Ext	P10	2	4.75, 5.25	3.5	200	\$5.25	67
ADS821	10	40,000	Pipeline	1 SE/1 Diff	58	58	62	2LSB	1	10	Int/Ext	P10	1	4.75, 5.25	4.75, 5.25	390	\$13.05	67
THS1040	10	40,000	Pipeline	1 SE/1 Diff	60	57	70	1.5LSB	0.9	10	Int/Ext	P10	2	3, 3.6	3, 3.6	100	\$5.10	67
THS1041	10	40,000	Pipeline	1 SE/1 Diff	60	57	70	1.5LSB	1	10	Int/Ext	P10	2	3, 3.6	3, 3.6	103	\$5.45	67
ADS5203	10	40,000	Pipeline	2 SE/2 Diff	60	60.5	73	1.5LSB	1	10	Int/Ext	P10	1	3, 3.6	3, 3.6	240	\$9.65	67
ADS5204	10	40,000	Pipeline	2 SE/2 Diff, PGA	60	60.5	73	1.5LSB	1	10	Int/Ext	P10	1	3, 3.6	3, 3.6	275	\$11.05	67
ADS5121	10	40,000	Pipeline	8 Diff	59	60	74	1.5LSB	1	10	Int/Ext	P10	2	1.65, 2.0	1.65, 3.6	500	\$38.85	67
ADS5120	10	40,000	Pipeline	8 Diff	57	58	72	1.5LSB	1	10	Int/Ext	P10	1	1.65, 2	1.65, 2	794	\$36.15	67

\*Suggested resale price in U.S. dollars in quantities of 1,000.  
 New products are listed in bold red.  
 Preview products are listed in bold blue.

Device	Res. (Bits)	Sample Rate (kSPS)	Architecture	No. of Input Channels	SINAD (dB)	SNR (dB)	SFDR (dB)	INL (%)	DNL (±LSB)	MIMC	V <sub>REF</sub>	Interface	No. of Supplies	Analog Supply	Logic Supply	Power (mW)	Price*	Refer to Page
THS1030	10	30,000	Pipeline	1 SE/1 Diff	48.6	49.4	53	2LSB	1	10	Int/Ext	P10	2	3, 5.5	3, 5.5	150	\$3.75	67
THS1031	10	30,000	Pipeline	1 SE/1 Diff	56	49.3	52.4	2LSB	1	10	Int/Ext	P10	2	3, 5.5	3, 5.5	160	\$4.10	67
AD5820	10	20,000	Pipeline	1 SE/1 Diff	60	60	62	2LSB	1	10	Int/Ext	P10	1	4.75, 5.25	4.75, 5.25	200	\$6.75	67
AD5900	10	20,000	Pipeline	1 SE/1 Diff	48	49	53	—	1	10	Int	P10	1	2.7, 3.7	3, 3	49	\$3.55	67
AD5901	10	20,000	Pipeline	1 SE/1 Diff	50	53	49	—	1	10	Ext	P10	1	2.7, 3.7	3, 3	54	\$3.40	67
THS10082	10	8,000	Pipeline	2 SE/1 Diff	59	61	65	1LSB	1	10	Int/Ext	P10	2	4.75, 5.25	3, 5.25	186	\$3.70	67
THS1009	10	8,000	Pipeline	2 SE/1 Diff	59	61	65	1LSB	1	10	Int/Ext	P10	2	4.75, 5.25	4.75, 5.25	186	\$3.20	67
THS10064	10	6,000	Pipeline	4 SE/2 Diff	59	61	65	1LSB	1	10	Int/Ext	P10	2	4.75, 5.25	3, 5.25	186	\$4.15	67
THS1007	10	6,000	Pipeline	4 SE/2 Diff	59	61	65	1LSB	1	10	Int/Ext	P10	2	4.75, 5.25	4.75, 5.25	186	\$3.70	67
TLV1562	10	2,000	Pipeline	4 SE/2 Diff	58	58	70.3	1.5LSB	1.5	10	Int/Ext	P10	2	2.7, 5.5	2.7, 5.5	15	\$4.15	67
TLV1571	10	1,250	SAR	1 SE	60	60	63	1LSB	1	10	Ext	P10	1	2.7, 5.5	2.7, 5.5	12	\$3.70	62
TLV1572	10	1,250	SAR	1 SE	60	—	62	1LSB	1	10	Ext	Serial, SPI	1	2.7, 5.5	2.7, 5.5	8.1	\$3.30	62
TLV1570	10	1,250	SAR	8 SE	60	61	63	1LSB	1	10	Int/Ext	Serial, SPI	1	2.7, 5.5	2.7, 5.5	9	\$3.80	62
TLV1578	10	1,250	SAR	8 SE	60	60	63	1LSB	1	10	Ext	P10	1	2.7, 5.5	2.7, 5.5	12	\$3.85	62
<b>AD57887</b>	10	1,000	SAR	1 SE	61	60	—	0.05	±1	10	Ext	Serial, SPI	1	2.5, 5.25	2.5, 5.25	11	\$1.50	62
TLC1514	10	400	SAR	4 SE/3 Diff	60	—	82	0.012	0.5	10	Int/Ext	Serial, SPI	1	4.5, 5.5	4.5, 5.5	10	\$2.90	62
TLC1518	10	400	SAR	8 SE/7 Diff	60	—	82	0.012	0.5	10	Int/Ext	Serial, SPI	1	4.5, 5.5	4.5, 5.5	10	\$3.45	62
<b>AD57826</b>	10	200	SAR	1 Diff	62	—	—	0.0048	1	10	Ext	Serial, SPI	1	2.7, 5.5	2.7, 5.5	0.6	\$1.25	62
<b>AD57867</b>	10	200	SAR	1 SE	61	60	—	0.05	±1	10	Ext	Serial, SPI	1	1.2, 3.6	1.2, 3.6	0.25	\$1.40	62
TLV1504	10	200	SAR	4 SE	60	—	83	0.05	0.5	10	Int/Ext	Serial, SPI	1	2.7, 5.5	2.7, 5.5	3.3	\$2.65	62
TLV1508	10	200	SAR	8 SE	60	—	83	0.05	0.5	10	Int/Ext	Serial, SPI	1	2.7, 5.5	2.7, 5.5	3.3	\$3.15	62
TLC1550	10	164	SAR	1 SE	—	—	—	0.05	0.5	10	Ext	P10	1	4.75, 5.5	4.75, 5.5	10	\$3.90	62
TLC1551	10	164	SAR	1 SE	—	—	—	0.1	1	10	Ext	P10	1	4.75, 5.5	4.75, 5.5	10	\$3.35	62
TLV1544	10	85	SAR	4 SE	—	—	—	0.1	1	10	Ext	Serial, SPI	1	2.7, 5.5	2.7, 5.5	1.05	\$1.95	62
TLV1548	10	85	SAR	8 SE	—	—	—	0.1	1	10	Ext	Serial, SPI	1	2.7, 5.5	2.7, 5.5	1.05	\$2.30	62
TLV1548-EP	10	85	SAR	8 SE	—	—	—	0.1	1	10	Ext	Serial, SPI	1	2.7, 5.5	2.7, 5.5	1.05	\$4.36	85
TLC1549	10	38	SAR	1 SE	—	—	—	0.1	1	10	Ext	Serial, SPI	1	4.5, 5.5	4.5, 5.5	4	\$1.71	62
TLC1542	10	38	SAR	11 SE	—	—	—	0.05	0.5	10	Ext	Serial, SPI	1	4.5, 5.5	4.5, 5.5	4	\$2.50	62
TLC1543	10	38	SAR	11 SE	—	—	—	0.1	1	10	Ext	Serial, SPI	1	4.5, 5.5	4.5, 5.5	4	\$1.90	62
TLC1543-EP	10	38	SAR	11 SE	—	—	—	0.1	1	10	Ext	Serial, SPI	1	4.5, 5.5	4.5, 5.5	4	\$3.89	85
TLC1541	10	32	SAR	11 SE	—	—	—	0.1	1	10	Ext	Serial, SPI	1	4.75, 5.25	4.75, 5.25	6	\$3.20	62
TLV5580	8	80,000	Pipeline	1 SE	—	44	53	1.4LSB	1.3	—	Int/Ext	P8	1	3, 3.6	3, 3.6	213	\$14.05	—
AD5831	8	80,000	Pipeline	1 SE/1 Diff	49	49	65	2LSB	1	8	Int/Ext	P8	2	4.75, 5.25	3, 5	310	\$3.15	67
AD5830	8	60,000	Pipeline	1 SE/1 Diff	48	49.5	65	1.5LSB	1	8	Int/Ext	P8	2	4.75, 5.25	3, 5	215	\$2.75	67
TLV5540	8	40,000	Flash	1 SE	—	44	42	1LSB	1	—	Int/Ext	P8	1	4.75, 5.25	4.75, 5.25	85	\$2.40	67
THS0942	8	40,000	Pipeline	2 SE/2 Diff	—	42.7	52	2.2LSB	2	8	Int/Ext	P8	1	3, 3.6	3, 3.6	320	\$5.05	67
TLV5535	8	35,000	Pipeline	1 SE	46	46.5	58	2.4LSB	1.3	—	Int/Ext	P8	1	3, 3.6	3, 3.6	106	\$2.40	67
AD5931	8	30,000	Pipeline	1 SE/1 Diff	45	48	49	2.5LSB	1	8	Ext	P8	2	2.7, 5.25	3, 5	154	\$2.20	67

New products are listed in bold red.

\*Suggested resale price in U.S. dollars in quantities of 1,000.



## ADC Selection Guide (Continued)

Device	Res. (Bits)	Sample Rate (kSPS)	Architecture	No. of Input Channels	SINAD (dB)	SNR (dB)	SFDR (dB)	INL (%)	DNL ( $\pm$ LSB)	NMC	V <sub>REF</sub>	Interface	No. of Supplies	Analog Supply	Logic Supply	Power (mW)	Price*	Refer to Page
ADS930	8	30,000	Pipeline	1 SE/1 Diff	45	46	50	2.5LSB	1	8	Int	P8	2	2.7, 5.25	3, 5	168	\$2.30	67
TLC5510	8	20,000	Pipeline	1 SE	—	46	42	1LSB	0.75	—	Ext	P8	1	4.75, 5.25	4.75, 5.25	127.5	\$2.35	67
TLC5510A	8	20,000	Pipeline	1 SE	—	46	42	1LSB	0.75	—	Ext	P8	1	4.75, 5.25	4.75, 5.25	150	\$2.35	67
TLV571	8	1,250	SAR	1 SE	49	49	51	0.5	0.5	8	Ext	P8	2	2.7, 5.25	2.7, 5.25	12	\$2.35	62
<b>AD57888</b>	8	1,000	SAR	1 SE	49	—	65	0.3	0.3	8	Ext	Serial, SPI	1	2.5, 5.25	2.5, 5.25	11	\$0.85	62
TLC0820A	8	392	SAR	1 SE	—	—	—	0.2	0.5	8	Ext	P8	1	4.5, 8	4.5, 8	37.5	\$1.90	62
<b>AD57827</b>	8	250	SAR	1 Diff	48	—	—	0.2	1	8	Ext	Serial, SPI	1	2.7, 5.5	2.7, 5.5	0.6	\$1.00	62
<b>AD57868</b>	8	200	SAR	1 SE	49	49	66	0.5	0.5	8	Ext	Serial, SPI	1	1.2, 3.6	1.2, 3.6	0.25	\$0.80	62
TLC545	8	76	SAR	19 SE	—	—	—	0.2	0.5	8	Ext	Serial, SPI	1	4.75, 5.25	4.75, 5.25	6	\$3.10	62
AD57830	8	75	SAR	8 SE/4 Diff	50	50	68	0.19	0.5	8	Int/Ext	Serial, I <sup>2</sup> C	1	2.7, 5.25	2.7, 5.25	0.675	\$1.40	62
TLV0831	8	49	SAR	1 SE	—	—	—	0.2	0.5	8	Ext	Serial, SPI	1	2.7, 3.6	2.7, 3.6	0.66	\$1.40	62
TLC548	8	45.5	SAR	1 SE	—	—	—	0.2	0.5	8	Ext	Serial, SPI	1	3, 6	3, 6	9	\$1.20	62
TLV0832	8	44.7	SAR	2 SE/1 Diff	—	—	—	0.2	0.5	8	Ext	Serial, SPI	1	2.7, 3.6	2.7, 3.6	5	\$1.40	62
TLV0834	8	41	SAR	4 SE/2 Diff	—	—	—	0.2	0.5	8	Ext	Serial, SPI	1	2.7, 3.6	2.7, 3.6	0.66	\$1.45	62
TLC549	8	40	SAR	1 SE	—	—	—	0.2	0.5	8	Ext	Serial, SPI	1	3, 6	3, 6	9	\$0.95	62
TLC541	8	40	SAR	11 SE	—	—	—	0.2	0.5	8	Ext	Serial, SPI	1	4.75, 5.5	4.5, 5.5	6	\$1.50	62
TLV0838	8	37.9	SAR	8 SE/4 Diff	—	—	—	0.2	0.5	8	Ext	Serial, SPI	1	2.7, 3.6	2.7, 3.6	0.66	\$1.45	62
TLC0831	8	31	SAR	1 Diff	—	—	—	0.2	0.4	8	Ext	Serial, SPI	1	4.5, 5.5	4.5, 5.5	3	\$1.40	62
TLC542	8	25	SAR	11 SE	—	—	—	0.2	0.5	8	Ext	Serial, SPI	1	4.75, 5.25	4.75, 5.25	6	\$1.50	62
TLC0832	8	22	SAR	2 SE/1 Diff	—	—	—	0.2	0.4	8	Ext	Serial, SPI	1	4.5, 5.5	4.5, 5.5	12.5	\$1.40	62
TLC0834	8	20	SAR	4 SE/2 Diff	—	—	—	0.2	0.4	8	Ext	Serial, SPI	1	4.5, 5.5	4.5, 5.5	3	\$1.45	62
TLC0838	8	20	SAR	8 SE/4 Diff	—	—	—	0.2	0.4	8	Ext	Serial, SPI	1	4.5, 5.5	4.5, 5.5	3	\$1.45	62

\*Suggested resale price in U.S. dollars in quantities of 1,000.

New products are listed in bold red.

## DAC Selection Guide

Device	Res. (Bits)	Settling Time ( $\mu$ s)	Architecture	Number of Output Channels	Update Rate (MSPS)	Output (V)	DNL ( $\pm$ LSB)	INL (%)	Monotonic (Bits)	Interface	V <sub>REF</sub>	Supply Voltage (V)	Power (mW) (typ)	Price*	Refer to Page #
DAC1220	20	10000	Delta-Sigma	1	—	5	1	0.0015	20	Serial, SPI	Ext	+4.75 to 5.25	2.5	\$6.33	68
DAC5887	16	0.0104	I-Steering	2	500	20mA	4	4LSB	—	2 x P16	In/Ext	1.8/3.3	700	\$22.50	75
DAC5886	16	0.012	I-Steering	2	500	—	9	12LSB	—	2 x P16	In/Ext	1.8/3.3	400	\$19.75	75
<b>DAC8811</b>	16	0.5	R-2R	1	—	$\pm V_{REF}/MDAC$	1	0.0015	16	Serial, SPI	Ext	2.75 to 5.25	0.5	\$8.50	70, 71
<b>DAC8820</b>	16	0.5	R-2R	1	—	I <sub>OUT</sub> ( $\pm 10V$ )	1	0.0015	16	P16	Ext	2.75 to 5.25	0.025	\$8.50	70, 71
<b>DAC8822</b>	16	0.5	R-2R	2	—	I <sub>OUT</sub> ( $\pm 10V$ )	1	0.0015	16	P16	Ext	2.75 to 5.25	0.025	\$11.70	71
<b>DAC8812</b>	16	0.5	R-2R	2	—	$\pm V_{REF}/MDAC$	1	0.0015	16	Serial, SPI	Ext	2.75 to 5.25	0.5	\$8.40	71
<b>DAC8830</b>	16	1	R-2R	1	—	$\pm V_{REF}$	1	0.0015	16	Serial, SPI	Ext	2.75 to 5.25	0.5	\$7.95	69, 71
<b>DAC8831</b>	16	1	R-2R	1	—	$\pm V_{REF}$	1	0.0015	16	Serial, SPI	Ext	2.75 to 5.25	0.5	\$7.95	69, 71
<b>DAC8580</b>	16	1	String	1	—	V <sub>REF</sub>	1	0.0987	16	Serial, SPI	Ext	2.75 to 5.25	60	\$3.00	72
<b>DAC8581</b>	16	1	String	1	—	$\pm V_{REF}$	1	0.0987	16	Serial, SPI	Ext	2.75 to 5.25	60	\$3.00	72
<b>DAC8814</b>	16	1	R-2R	4	—	$\pm V_{REF}/MDAC$	1	0.0015	16	Serial, SPI	Ext	2.75 to 5.25	0.5	\$19.30	70, 71
<b>DAC8881</b>	16	2	R-2R	1	—	$\pm V_{REF}$ (5)	1	0.0015	16	Serial, SPI	Ext	2.75 to 5.25	60	\$6.00	71
<b>DAC8871</b>	16	5	R-2R	1	—	$\pm 10$	1	0.0015	16	Serial, SPI	Ext	2.75 to 5.25 to 15.75	15	\$7.25	69, 71
DAC7731	16	5	R-2R	1	—	$\pm 10, \pm 10$	1	0.0015	16	Serial, SPI	In/Ext	$\pm 14.25$ to 15.75	100	\$8.20	71
DAC7741	16	5	R-2R	1	—	$\pm 10$	1	0.0015	16	P16	In/Ext	$\pm 14.25$ to 15.75	100	\$8.30	71
DAC7742	16	5	R-2R	1	—	$\pm 10, \pm 10$	1	0.0015	16	P16	In/Ext	$\pm 14.25$ to 15.75	100	\$8.70	71
DAC712	16	10	R-2R	1	—	$\pm 10$	1	0.003	15	P16	Ext	$\pm 11.4$ to 16.5	525	\$14.50	71
DAC714	16	10	R-2R	1	—	$\pm 10$	1	0.0015	16	Serial, SPI	Ext	$\pm 11.4$ to 16.5	525	\$14.50	71
DAC715	16	10	R-2R	1	—	10	1	0.003	16	P16	Ext	$\pm 11.4$ to 16.5	525	\$15.85	71
DAC716	16	10	R-2R	1	—	10	2	0.003	16	Serial, SPI	Ext	$\pm 11.4$ to 16.5	525	\$15.85	71
DAC7631	16	10	R-2R	1	—	$\pm V_{REF}, \pm V_{REF}$	2	0.0015	15	Serial, SPI	Ext	$\pm 11.4$ to 16.5	1.8	\$5.85	71
DAC7641	16	10	R-2R	1	—	$\pm V_{REF}, \pm V_{REF}$	2	0.0015	15	Serial, SPI	Ext	$\pm 0r + 4.75$ to 5.25	1.8	\$6.30	71
<b>DAC8551</b>	16	10	String	1	—	$\pm V_{REF}$	1	0.012	16	Serial, SPI	Ext	2.75 to 5.25	1	\$2.95	72
<b>DAC8550</b>	16	10	String	1	—	$\pm V_{REF}$	1	0.012	16	Serial, SPI	Ext	2.75 to 5.25	1	\$2.95	72
DAC8501	16	10	String	1	—	$\pm V_{REF}/MDAC$	1	0.0987	16	Serial, SPI	Ext	+2.7 to 5.5	0.72	\$3.00	72
DAC8531	16	10	String	1	—	$\pm V_{REF}$	1	0.0987	16	Serial, SPI	Ext	+2.7 to 5.5	0.72	\$3.00	72
DAC8541	16	10	String	1	—	$\pm V_{REF}$	1	0.096	16	P16	Ext	+2.7 to 5.5	0.72	\$3.00	72
DAC8571	16	10	String	1	—	$\pm V_{REF}$	1	0.0987	16	Serial, I <sup>2</sup> C	Ext	+2.7 to 5.5	0.42	\$2.95	72
<b>DAC8552</b>	16	10	String	2	—	$\pm V_{REF}$	1	0.012	16	Serial, SPI	Ext	2.75 to 5.25	2	\$6.25	72
DAC7632	16	10	R-2R	2	—	$\pm V_{REF}, \pm V_{REF}$	2	0.0015	15	Serial, SPI	Ext	$\pm 0r + 4.75$ to 5.25	2.5	\$10.45	71
DAC7642	16	10	R-2R	2	—	$\pm V_{REF}, \pm V_{REF}$	2	0.0015	15	Serial, SPI	Ext	$\pm 0r + 4.75$ to 5.25	2.5	\$10.55	71
DAC7643	16	10	R-2R	2	—	$\pm V_{REF}, \pm V_{REF}$	2	0.0015	15	P16	Ext	$\pm 0r + 4.75$ to 5.25	2.5	\$10.55	71
DAC8532	16	10	String	2	—	$\pm V_{REF}$	1	0.0987	16	Serial, SPI	Ext	+2.7 to 5.5	1.35	\$5.35	72
<b>DAC8554</b>	16	10	String	4	—	$\pm V_{REF}$	1	0.0122	16	Serial, SPI	Ext	2.75 to 5.25	4	\$10.40	70, 72
<b>DAC8555</b>	16	10	String	4	—	$\pm V_{REF}$	1	0.0122	16	Serial, SPI	Ext	2.75 to 5.25	4	\$10.40	70, 72
DAC8544	16	10	String	4	—	Ext	1	0.0987	16	P16	Ext	2.75 to 5.25	2	\$9.75	72

\*Suggested resale price in U.S. dollars in quantities of 1,000.

New products are listed in bold red.

Preview products are listed in bold blue.

## DAC Selection Guide (Continued)

Device	Res. (Bits)	Settling Time (µs)	Architecture	Number of Output Channels	Update Rate (MSPS)	Output (V)	DNL (±LSB)	INL (%)	Monotonic (Bits)	Interface	V <sub>REF</sub>	Supply Voltage (V)	Power (mW) (typ)	Price*	Refer to Page
DAC7634	16	10	R-2R	4	—	+V <sub>REF</sub> , ±V <sub>REF</sub>	2	0.0015	15	Serial, SPI	Ext	±0r +4.75 to 5.25	7.5	\$19.95	71
DAC7644	16	10	R-2R	4	—	+V <sub>REF</sub> , ±V <sub>REF</sub>	2	0.0015	15	P16	Ext	±0r +4.75 to 5.25	7.5	\$19.95	71
DAC7734	16	10	R-2R	4	—	+V <sub>REF</sub> , ±V <sub>REF</sub>	1	0.0015	16	Serial, SPI	Ext	±0r +4.75 to 15.75	50	\$31.45	71
DAC7744	16	10	R-2R	4	—	+V <sub>REF</sub> , ±V <sub>REF</sub>	1	0.0015	16	P16	Ext	±0r +4.75 to 15.75	50	\$31.45	71
DAC8534	16	10	String	4	—	+V <sub>REF</sub>	1	0.0987	16	Serial, SPI	Ext	+2.7 to 5.5	0.42	\$8.75	72
DAC8574	16	10	String	4	—	+V <sub>REF</sub>	1	0.0987	16	Serial, I2C	Ext	+2.7 to 5.5	2.7	\$10.25	72
DAC7654	16	12	R-2R	4	—	±2.5	1	0.0015	16	Serial, SPI	Int	±0r +4.75 to 15.75	18	\$21.80	71
DAC7664	16	12	R-2R	4	—	±2.5	1	0.0015	16	P16	Int	±0r +4.75 to 15.75	18	\$20.75	71
DAC1221	16	2000	Delta-Sigma	1	—	2.5	1	0.0015	16	Serial, SPI	Ext	+2.7 to 3.3	1.2	\$5.01	68
DAC5675	14	0.005	I-Steering	1	400	20mA	2LSB	4LSB	—	LVDS/P14	Int/Ext	3	820	\$29.45	75
DAC5675-EP	14	0.005	I-Steering	1	400	20mA	2	4LSB	—	LVDS/P14	Int/Ext	+3.15 to 3.6	820	\$50.00	85
DAC5672	14	0.02	I-Steering	2	200	20mA	3LSB	4LSB	—	2 x P14	Int	3.0 to 5.25	330	\$13.25	74, 75
DAC904	14	0.03	I-Steering	1	165	20mA	1.75LSB	2.5LSB	—	P14	Int/Ext	+3.0 to 5.5	170	\$6.25	75
DAC2904	14	0.03	I-Steering	2	125	20mA	4LSB	5LSB	—	2 x P14	Int/Ext	+3.0 to 5.5	310	\$13.25	75
THS5671A	14	0.035	I-Steering	1	125	20mA	3.5	7LSB	—	P14	Int/Ext	+3.0 to 5.5	175	\$12.85	—
<b>DAC8801</b>	14	0.5	R-2R	1	—	±V <sub>REF</sub> /MDAC	1	0.0061	14	Serial, SPI	Ext	2.75 to 5.25	0.3	\$5.50	70, 71
<b>DAC8802</b>	14	0.5	R-2R	2	—	±V <sub>REF</sub> /MDAC	1	0.0061	14	Serial, SPI	Ext	2.75 to 5.25	0.5	\$7.25	70, 71
<b>DAC8803</b>	14	0.5	R-2R	4	—	±V <sub>REF</sub> /MDAC	1	0.0061	14	Serial, SPI	Ext	2.75 to 5.25	0.5	\$14.40	70, 71
<b>DAC8806</b>	14	0.5	R-2R	1	—	I <sub>OUT</sub> (±10V)	1	0.0061	14	P16	Ext	2.75 to 5.25	0.025	\$5.50	71
DAC5674	12	0.02	I-Steering	1	400	20mA	2LSB	3.5LSB	—	P14	Int/Ext	1.8/3.3	420	\$15.00	75
<b>DAC5662</b>	12	0.02	I-Steering	2	200	20mA	2LSB	2LSB	—	Serial	Ext	+3.0 to 3.6	330	\$10.70	74, 75
DAC2932	12	0.025	I-Steering	2	40	2mA	0.5LSB	2LSB	—	P12	Int/Ext	+2.7 to 3.3	29	\$8.35	75
DAC902	12	0.03	I-Steering	1	165	20mA	1.75LSB	2.5LSB	—	P12	Int/Ext	+3.0 to 5.25	170	\$6.25	75
DAC2902	12	0.03	I-Steering	2	125	20mA	2.5	3LSB	—	2 x P12	Int/Ext	+3.0 to 5.25	310	\$15.41	75
THS5661A	12	0.035	I-Steering	1	125	20mA	2LSB	4LSB	—	P12	Int/Ext	+3.0 to 5.25	175	\$6.25	75
<b>DAC7811</b>	12	0.5	R-2R	1	—	±V <sub>REF</sub> /MDAC	1	0.0244	12	Serial, SPI	Ext	2.75 to 5.25	0.5	\$3.15	71
<b>DAC7821</b>	12	0.5	R-2R	1	—	±V <sub>REF</sub> /MDAC	1	0.0244	12	P12	Ext	2.75 to 5.25	0.5	\$3.15	71
<b>DAC7822</b>	12	0.5	R-2R	1	—	±V <sub>REF</sub> /MDAC	1	0.0244	12	P12	Ext	2.75 to 5.25	0.5	\$4.75	71
DAC7800	12	0.8	R-2R	2	—	1mA	1	0.012	12	Serial, SPI	Ext	+4.5 to 5.5	1	\$13.55	72
DAC7801	12	0.8	R-2R	2	—	1mA	1	0.012	12	P12	Ext	+4.5 to 5.5	1	\$17.95	72
DAC7802	12	0.8	R-2R	2	—	1mA	1	0.012	12	P12	Ext	+4.5 to 5.5	1	\$14.00	72
DAC7541	12	1	R-2R	1	—	±V <sub>REF</sub> /MDAC	0.5	0.012	12	P12	Ext	+5 to 16	30	\$6.70	72
DAC8043	12	1	R-2R	1	—	±V <sub>REF</sub> /MDAC	1	0.012	12	Serial, SPI	Ext	+4.75 to 5.25	2.5	\$5.25	72
TLV5613	12	1	String	1	—	+V <sub>REF</sub>	1	0.1	12	P8	Ext	+2.7 to 5.5	1.2	\$2.60	72
TLV5619	12	1	String	1	—	+V <sub>REF</sub>	1	0.08	12	P12	Ext	+2.7 to 5.5	4.3	\$2.60	72, 85
TLV5633	12	1	String	1	—	+2, 4	0.5	0.08	12	P8	Int/Ext	+2.7 to 5.5	2.7	\$4.70	72
TLV5636	12	1	String	1	—	+2, 4	1	0.1	12	Serial, SPI	Int/Ext	+2.7 to 5.25	4.5	\$3.65	72
TLV5639	12	1	String	1	—	+2, 4	0.5	0.1	12	P12	Int/Ext	+2.7 to 5.25	2.7	\$3.45	72

\*Suggested resale price in U.S. dollars in quantities of 1,000.

New products are listed in **bold red**.

Preview products are listed in **bold blue**.

## DAC Selection Guide (Continued)

Device	Res. (Bits)	Settling Time ( $\mu$ s)	Architecture	Number of Output Channels	Update Rate (MSPS)	Output (V)	DNL ( $\pm$ LSB)	INL (%)	Monotonic (Bits)	Interface	$V_{REF}$	Supply Voltage (V)	Power (mW) (typ)	Price*	Refer to Page #
TLV5619-EP	12	1	String	1	—	+ $V_{REF}$	1	0.08	12	P12	Ext	+2.7 to 5.5	4.3	\$7.91	72, 85
TLV5638	12	1	String	2	—	+2, 4	1	0.1	12	Serial, SPI	Int/Ext	+2.7 to 5.25	4.5	\$3.25	72
TLV5638-EP	12	1	String	2	—	+2, 4	1	0.1	12	Serial, SPI	Int/Ext	+2.7 to 5.25	4.5	\$9.94	72, 85
TLV5638M	12	1	String	2	—	+2, 4	1	0.1	12	Serial, SPI	Int/Ext	+2.7 to 5.25	4.5	\$32.50	85
TLV5610	12	1	String	8	—	+ $V_{REF}$	1	0.4	12	Serial, SPI	Ext	+2.7 to 5.5	18	\$8.50	72
TLV5630	12	1	String	8	—	+ $V_{REF}$	1	0.4	12	Serial, SPI	Int/Ext	+2.7 to 5.5	18	\$8.85	72
DAC7545	12	2	R-2R	1	—	$\pm V_{REF}/MDAC$	1	0.012	12	P12	Ext	+5 to 16	30	\$5.25	72
TLV5618A	12	2.5	String	2	—	+ $V_{REF}$	1	0.08	12	Serial, SPI	Ext	+2.7 to 5.5	1.8	\$4.75	72, 85
TLV5618A-EP	12	2.5	String	2	—	+ $V_{REF}$	1	0.08	12	Serial, SPI	Ext	+2.7 to 5.5	1.8	\$11.78	72, 85
TLV5616	12	3	String	1	—	+ $V_{REF}$	1	0.1	12	Serial, SPI	Ext	+2.7 to 5.5	0.9	\$2.60	72
TLV5618AM	12	3	String	2	—	+ $V_{REF}$	1	0.1	12	Serial, SPI	Ext	+2.7 to 5.5	1.8	\$28.23	72, 85
TLV5614	12	3	String	4	—	+ $V_{REF}$	1	0.1	12	Serial, SPI	Ext	+2.7 to 5.5	3.6	\$7.45	72
DAC811	12	4	R-2R	1	—	+10, $\pm 5$ , 10	0.5	0.006	12	P12	Int	$\pm 0V$ + 11.4 to 16.5	625	\$11.00	71
DAC813	12	4	R-2R	1	—	+10, $\pm 5$ , 10	0.5	0.006	12	P12	Int/Ext	$\pm 0V$ + 11.4 to 16.5	270	\$12.60	71
<b>DAC7551</b>	12	5	String	1	—	+ $V_{REF}$	1	0.012	12	Serial, SPI	Ext	2.75 to 5.25	0.27	\$1.40	72
<b>DAC7552</b>	12	5	String	2	—	+ $V_{REF}$	1	0.024	12	Serial, SPI	Ext	2.75 to 5.25	0.675	\$2.35	72
<b>DAC7553</b>	12	5	String	2	—	+ $V_{REF}$	1	0.024	12	Serial, SPI	Ext	2.75 to 5.25	0.675	\$2.35	72
<b>DAC7554</b>	12	5	String	4	—	+ $V_{REF}$	1	0.012	12	Serial, SPI	Ext	2.75 to 5.25	1	\$5.60	72
<b>DAC7558</b>	12	5	String	8	—	+ $V_{REF}$	1	0.012	12	Serial, SPI	Ext	2.75 to 5.25	2	\$10.40	72
DAC7512	12	10	String	1	—	+ $V_{REF}$	1	0.38	12	Serial, SPI	Ext	+2.7 to 5.5	0.345	\$1.45	72
DAC7513	12	10	String	1	—	+ $V_{REF}$	1	0.38	12	Serial, SPI	Ext	+2.7 to 5.5	0.3	\$1.45	72
DAC7571	12	10	String	1	—	+ $V_{REF}$	—	0.096	12	Serial, I <sup>2</sup> C	Ext	+2.7 to 5.5	0.85	\$1.55	71
DAC7611	12	10	R-2R	1	—	4.096	1	0.012	12	Serial, SPI	Int	+4.75 to 5.25	5	\$2.55	71
DAC7613	12	10	R-2R	1	—	+ $V_{REF}$ , $\pm V_{REF}$	1	0.012	12	P12	Ext	$\pm 0V$ + 4.75 to 5.25	1.8	\$2.50	71
DAC7621	12	10	R-2R	1	—	4.096	1	0.012	12	P12	Int	+4.75 to 5.25	2.5	\$2.75	71
DAC7612	12	10	R-2R	2	—	4.096	1	0.012	12	Serial, SPI	Int	+4.75 to 5.25	3.5	\$2.70	71
DAC7573	12	10	String	4	—	+ $V_{REF}$	1	0.096	12	Serial, I <sup>2</sup> C	Ext	2.75 to 5.25	0.85	\$6.15	71
DAC7574	12	10	String	4	—	+ $V_{REF}$	—	0.096	12	Serial, I <sup>2</sup> C	Ext	+2.7 to 5.5	0.85	\$6.15	71
DAC7614	12	10	R-2R	4	—	+ $V_{REF}$ , $\pm V_{REF}$	1	0.012	12	Serial, SPI	Ext	$\pm 0V$ + 4.75 to 5.25	15	\$6.70	71
DAC7615	12	10	R-2R	4	—	+ $V_{REF}$ , $\pm V_{REF}$	1	0.012	12	Serial, SPI	Ext	$\pm 0V$ + 4.75 to 5.25	15	\$6.70	71
DAC7616	12	10	R-2R	4	—	+ $V_{REF}$ , $\pm V_{REF}$	1	0.012	12	Serial, SPI	Ext	+3 to 3.6	2.4	\$5.40	71
DAC7617	12	10	R-2R	4	—	+ $V_{REF}$ , $\pm V_{REF}$	1	0.012	12	Serial, SPI	Ext	+3 to 3.6	2.4	\$5.40	71
DAC7624	12	10	R-2R	4	—	$\pm V_{REF}$	1	0.012	12	P12	Ext	$\pm 0V$ + 4.75 to 5.25	15	\$10.25	71
DAC7625	12	10	R-2R	4	—	$\pm V_{REF}$	1	0.012	12	P12	Ext	$\pm 0V$ + 4.75 to 5.25	15	\$10.25	71
DAC7714	12	10	R-2R	4	—	$\pm V_{REF}$	1	0.012	12	Serial, SPI	Ext	$\pm 0V$ + 14.25 to 15.75	45	\$11.45	71
DAC7715	12	10	R-2R	4	—	$\pm V_{REF}$	1	0.012	12	Serial, SPI	Ext	$\pm 0V$ + 14.25 to 15.75	45	\$11.45	72
DAC7724	12	10	R-2R	4	—	$\pm V_{REF}$	1	0.012	12	P12	Ext	$\pm 0V$ + 14.25 to 15.75	45	\$11.85	72
DAC7725	12	10	R-2R	4	—	$\pm V_{REF}$	1	0.012	12	P12	Ext	$\pm 0V$ + 14.25 to 15.75	45	\$11.85	72

\*Suggested resale price in U.S. dollars in quantities of 1,000.

New products are listed in bold red.

## DAC Selection Guide (Continued)

Device	Res. (Bits)	Settling Time ( $\mu$ s)	Architecture	Number of Output Channels	Update Rate (MSPS)	Output (V)	DNL ( $\pm$ LSB)	INL (%)	Monotonic (Bits)	Interface	$V_{REF}$	Supply Voltage (V)	Power (mW) (typ)	Price*	Refer to Page #
DAC5852	10	0.02	I-Steering	2	275	20mA	1LSB	0.5LSB	12	Serial	Int/Ext	3.0 to 3.6	290	\$7.60	74
DAC900	10	0.03	I-Steering	1	165	20mA	0.5LSB	1LSB	10	P10	Int/Ext	+3.0 to 5.25	170	\$4.25	75
DAC2900	10	0.03	I-Steering	2	125	20mA	1LSB	1LSB	—	2 x P10	Int/Ext	+3.0 to 5.25	310	\$6.00	75
THS5851A	10	0.035	I-Steering	1	125	20mA	0.5LSB	1LSB	—	P10	Int/Ext	+3 to 5.5	175	\$4.25	75
TLV5637	10	0.8	String	2	—	+2, 4	0.5	0.1	10	Serial, SPI	Int/Ext	+2.7 to 5.25	4.2	\$3.20	72
TLV5608	10	1	String	8	—	+ $V_{REF}$	1	0.4	10	Serial, SPI	Ext	+2.7 to 5.5	18	\$4.90	72
TLV5631	10	1	String	8	—	+ $V_{REF}$	1	0.4	10	Serial, SPI	Int/Ext	+2.7 to 5.5	18	\$5.60	72
TLV5617A	10	2.5	String	2	—	+ $V_{REF}$	0.5	0.1	10	Serial, SPI	Ext	+2.7 to 5.5	1.8	\$2.25	72
TLV5606	10	3	String	1	—	+ $V_{REF}$	1	0.15	10	Serial, SPI	Ext	+2.7 to 5.5	0.9	\$1.30	72
TLV5604	10	3	String	4	—	+ $V_{REF}$	1	0.05	10	Serial, SPI	Ext	+2.7 to 5.5	3	\$3.70	72
<b>DAC6571</b>	10	9	String	1	—	$V_{DD}$	0.5	0.195	10	Serial, I2C	Ext	2.75 to 5.25	0.5	\$1.40	72
<b>DAC6573</b>	10	9	String	4	—	+ $V_{REF}$	0.5	0.195	10	Serial, I2C	Ext	2.75 to 5.25	1.5	\$3.05	73
<b>DAC6574</b>	10	9	String	4	—	+ $V_{REF}$	0.5	0.195	10	Serial, I2C	Ext	2.7 to 5.5	1.5	\$3.05	73
TLCS5815	10	12.5	String	1	—	+ $V_{REF}$	0.5	0.1	10	Serial, SPI	Ext	+4.5 to 5.5	0.75	\$1.90	73
DAC908	8	0.03	I-Steering	1	165	20mA	0.5LSB	0.5LSB	—	P8	Ext	+3.0 to 5.25	170	\$2.90	75
THS5802	8	0.03	I-Steering	1	30	20mA	0.5LSB	0.5LSB	—	P8	Ext	+4.75 to 5.25	80	\$1.55	75
THS5841A	8	0.035	I-Steering	1	100	20mA	0.5LSB	1LSB	—	P8	Ext	+3.0 to 5.25	100	\$2.90	75
TLC7524	8	0.1	R-2R	1	—	1mA	0.5	0.2	8	P8	Ext	+4.75 to 5.25	5	\$1.45	73
TLC7528	8	0.1	R-2R	2	—	1mA	0.5	0.2	8	P8	Ext	+4.75 to 15.75	7.5	\$1.55	73
TLC7628	8	0.1	R-2R	2	—	2mA	0.5	0.2	8	P8	Ext	+10.8 to 15.75	20	\$1.45	73
TLV5626	8	0.8	String	2	—	+2, 4	0.5	0.4	8	Serial, SPI	Int/Ext	+2.7 to 5.5	4.2	\$1.90	73
TLV5624	8	1	String	1	—	+2, 4	0.2	0.2	8	Serial, SPI	Int/Ext	+2.7 to 5.5	0.9	\$1.60	73
TLV5629	8	1	String	8	—	+ $V_{REF}$	1	0.4	8	Serial, SPI	Ext	+2.7 to 5.5	18	\$3.15	73
TLV5632	8	1	String	8	—	+2, 4	1	0.4	8	Serial, SPI	Int/Ext	+2.7 to 5.5	18	\$3.35	73
TLV5627	8	2.5	String	4	—	+ $V_{REF}$	0.5	0.2	8	Serial, SPI	Ext	+2.7 to 5.5	3	\$2.05	73
TLV5623	8	3	String	1	—	+ $V_{REF}$	0.2	0.2	8	Serial, SPI	Ext	+2.7 to 5.5	2.1	\$0.99	73
TLV5625	8	3	String	2	—	+ $V_{REF}$	0.2	0.2	8	Serial, SPI	Ext	+2.7 to 5.5	2.4	\$1.70	73
TLC7225	8	5	R-2R	4	—	$\pm V_{REF}$	1	0.4	8	P8	Ext	$\pm 0$ + 11.4 to 16.5	75	\$2.35	73
TLC7226	8	5	R-2R	4	—	+ $V_{REF}$	1	0.4	8	P8	Ext	$\pm 0$ + 11.4 to 16.5	90	\$2.15	73, 85
TLC7226M	8	5	R-2R	4	—	+ $V_{REF}$	1	0.4	8	P8	Ext	$\pm 0$ + 11.4 to 16.5	90	\$78.98	85
<b>DAC6571</b>	8	8	String	1	—	$V_{DD}$	0.25	0.195	8	Serial, I2C	Int	2.75 to 5.25	0.5	\$0.90	73
<b>DAC6573</b>	8	8	String	4	—	+ $V_{REF}$	0.25	0.195	8	Serial, I2C	Ext	2.75 to 5.25	1.5	\$2.55	73
<b>DAC6574</b>	8	8	String	4	—	+ $V_{REF}$	0.25	0.195	8	Serial, I2C	Ext	2.7 to 5.5	1.5	\$2.55	73
TLV5620	8	10	R-2R	4	—	+ $V_{REF}$	0.9	0.2	8	Serial, SPI	Ext	+2.7 to 5.5	6	\$1.00	7, 73
TLV5621	8	10	R-2R	4	—	+ $V_{REF}$	0.9	0.4	8	Serial, SPI	Ext	+2.7 to 5.5	3.6	\$1.65	73
TLCS5820	8	10	String	4	—	+ $V_{REF}$	0.9	0.4	8	Serial, SPI	Ext	+4.75 to 5.25	8	\$1.50	73
TLCS5828	8	10	String	8	—	+ $V_{REF}$	0.9	0.4	8	Serial, SPI	Ext	+4.75 to 5.25	15	\$2.45	73
TLV5628	8	10	String	8	—	+ $V_{REF}$	0.9	0.4	8	Serial, SPI	Ext	+2.7 to 5.25	12	\$2.20	73

\*Suggested resale price in U.S. dollars in quantities of 1,000.

New products are listed in bold red.

 **Audio DACs and ADCs**
**Audio DACs and ADCs Selection Guide**

Device	Description	Resolution (Bits) (max)	Dynamic Range (dB)	Sampling Rate (kHz) (max)	Config.	Audio Data	Power	Package(s)	Price*
						Format	Supply (V)		
<b>DACs</b>									
PCM1792/4A	High Performance, Stereo Audio DAC, Adv. Seg.	24	128	192	Stereo	Normal, I <sup>2</sup> S, DSD	+3.3 and +5	SSOP-28	\$13.65
PCM1796/8	High Performance, Stereo Audio DAC, Adv. Seg.	24	123	192	Stereo	Normal, I <sup>2</sup> S, DSD	+3.3 and +5	SSOP-28	\$6.50
<b>PCM4104</b>	High Performance, 4 Ch Audio DAC, ΔΣ	24	118	192	4Ch	Left-Justified, I <sup>2</sup> S Right-Justified, TDM	+3.3 and +5	TQFP-48	\$4.95
PCM1738/30	High Performance, Stereo Audio DAC, ΔΣ	24	118	192	Stereo	Normal, I <sup>2</sup> S, DSD	+3.3 and +5	SSOP-28	\$5.25
PCM1791A	Stereo Audio DAC, Adv. Segment	24	113	192	Stereo	Normal, I <sup>2</sup> S, DSD	+3.3 and +5	SSOP-28	\$3.15
DSD1608	Enhanced Multiformat ΔΣ DAC	24	108	192	8Ch	Normal, I <sup>2</sup> S, DSD	+3.3 and +5	TQFP-52	\$6.00
PCM1753/54/55	Low-Cost Audio DAC w/Volume Control, ΔΣ, W/W (PCM1753/55), H/W (PCM1754), Open-Drain Output Zero Flag (PCM1755)	24	106	192	Stereo	Normal, I <sup>2</sup> S, L	+5	SSOP-16	\$1.05
PCM1737/39	CMOS, Multilevel ΔΣ w/Volume Control, ΔΣ, S/W (PCM1739), H/W (PCM1737)	24	106	192	Stereo	Normal, I <sup>2</sup> S, L	+3.3 and +5	SSOP-28	\$3.70
PCM1716/28	CMOS, Multilevel ΔΣ w/Volume Control ΔΣ, H/W (PCM1716/28), S/W (PCM1716)	24	106	96	Stereo	Normal, I <sup>2</sup> S, L	+5	SSOP-28	\$2.40
DSD1702	PCM/DSD Compatible DAC	24	106	192	Stereo	Normal, I <sup>2</sup> S, DSD	+3.3 and +5	SSOP-20	\$1.95
<b>PCM1780/81/82</b>	Low-Cost Audio DAC w/Volume Control DS, S/W (PCM1780/82), H/W (PCM1781) Open-Drain Output Zero Flag (PCM1782)	24	105	192	Stereo	Normal, I <sup>2</sup> S	+5	SSOP-16	\$1.00
PCM1742K	Low-Cost Audio DAC w/Volume Control, ΔΣ	24	106	192	Stereo	Normal, I <sup>2</sup> S	+3.3 and +5.5	SSOP-16	\$1.65
PCM1608K	CMOS, Multilevel ΔΣ DAC	24	105	192	8Ch	Normal, I <sup>2</sup> S	+3.3 and +5	LQFP-48	\$4.75
PCM1604	CMOS, Multilevel ΔΣ DAC	24	105	192	6Ch	Normal, I <sup>2</sup> S	+3.3 and +5	LQFP-48	\$4.60
PCM1602A	Low Cost, CMOS, Multilevel ΔΣ DAC	24	105	192	6Ch	Normal, I <sup>2</sup> S	+3.3 and +5	LQFP-48	\$2.80
PCM1748K	Low Cost, Audio DAC w/Volume Control	24	106	96	Stereo	Normal, I <sup>2</sup> S	+3.3 and +5	SSOP-16	\$1.30
PCM1600	CMOS, Multilevel ΔΣ DAC	24	105	96	6Ch	Normal, I <sup>2</sup> S	+3.3 and +5	LQFP-48	\$4.15
<b>PCM1680</b>	Low-Cost, 8 Ch Audio DAC, ΔΣ	24	105	192	8Ch	Normal, I <sup>2</sup> S	+5	SSOP-24	\$1.50
PCM1606	Low Cost, CMOS, Multilevel ΔΣ DAC	24	103	192	6Ch	Normal, I <sup>2</sup> S	+5	SSOP-20	\$2.00
PCM1742	Low-Cost Audio DAC w/Volume Control, ΔΣ	24	106	192	Stereo	Normal, I <sup>2</sup> S	+3.3 and +5	SSOP-16	\$1.65
PCM1608K	Highly Integrated, 8 Ch Audio DAC, ΔΣ	24	105	192	8Ch	Normal, I <sup>2</sup> S	+3.3 and +5	LQFP-48	\$4.75
PCM1602K	Low Cost, CMOS, Multilevel ΔΣ DAC	24	105	192	6Ch	Normal, I <sup>2</sup> S	+3.3 and +5	LQFP-48	\$3.55
PCM1748	Low Cost, Audio DAC w/Volume Control, ΔΣ	24	100	96	Stereo	Normal, I <sup>2</sup> S	+3.3 and +5	SSOP-16	\$1.20
TLV320DAC23	Low-Power DAC w/Headphone Amp, ΔΣ	24	100	96	Stereo	Normal, I <sup>2</sup> S	+1.5 and +3.3	SSOP-28	\$2.00
PCM1741	Low Cost, Audio DAC w/Volume Control, ΔΣ	24	98	96	Stereo	Normal, I <sup>2</sup> S	+3.3	SSOP-16	\$1.55
PCM1770/1	Low-Power DAC w/Headphone Amp, ΔΣ, S/W (PCM1770), H/W (PCM1771)	24	98	48	Stereo	Normal, I <sup>2</sup> S	+1.6 and +3.3	TSSOP-16, VQFN-20	\$1.50
PCM1772/3	Low-Power DAC w/Line Amp S/W (PCM1772), H/W (PCM1773)	24	98	48	N/A	I <sup>2</sup> S	+1.6 and +3.6	TSSOP-16, VQFN-20	\$1.50
<b>TLV320DAC26</b>	Low-Power DAC w/HP/Spkr Amp	24	97	53	Stereo	Normal, I <sup>2</sup> S, DSP	+1.8 and +3.6	QFN-32	\$2.95
PCM1720	CMOS, Multilevel ΔΣ w/Volume Control	24	96	96	Stereo	Normal, I <sup>2</sup> S	+5	SSOP-20	\$1.95
PCM1744	Low Cost Audio DAC, ΔΣ	24	95	96	Stereo	I <sup>2</sup> S	+5	SO-14	\$1.35
PCM1723	w/Int. PLL, Generate DAD/MPEG Clocks	24	94	96	Stereo	Normal, I <sup>2</sup> S	+5	SSOP-24	\$2.35
PCM1740	DAC w/Internal V <sub>COX</sub> and PLL	24	94	96	Stereo	Normal, I <sup>2</sup> S	+5	SSOP-24	\$3.15
PCM1727	DAC w/Int. Dual PLL	24	92	96	Stereo	Normal, I <sup>2</sup> S	+5	SSOP-24	\$3.15
PCM1602	BiCMOS, Sign Magnitude DAC	20	110	768	Mono	Serial Latched	±5	DIP-16, SOP-20	\$2.80
PCM1710	CMOS, Multilevel ΔΣ DAC	20	110	48	Stereo	Normal, I <sup>2</sup> S	±5	SOIC-28	\$4.20
PCM1719	Stereo Audio DAC w/Headphone Amplifier	18	96	48	Stereo	Normal, I <sup>2</sup> S	+5	SSOP-28	\$5.25
PCM1733	Low-Cost Audio DAC, ΔΣ	18	95	96	Stereo	Normal, I <sup>2</sup> S	+5	SO-14	\$1.35
PCM1725	Low-Cost Audio DAC	16	95	96	Stereo	Normal, I <sup>2</sup> S	+5	SO-14	\$1.30
PCM1793	CMOS, Adv. Segment DAC	24	113	192	Stereo	Normal, I <sup>2</sup> S, L	+3.3 and +5	SSOP-28	\$3.15

\*Suggested price in U.S. dollars in quantities of 1,000.

New products are listed in **bold red**.  
Preview products are listed in **bold blue**.



## Audio DACs and ADCs



## Audio DACs and ADCs Selection Guide (Continued)

Device	Description	Resolution (Bits) (max)	Dynamic Range (dB)	Sampling Rate (kHz) (max)	Config.	Audio Data Format	Power Supply (V)	Package(s)	Price*
<b>ADCs</b>									
<b>PCM4204</b>	High-Performance, 4-Channel Audio ADC, $\Delta\Sigma$	24	118	216	4 Ch	Normal, I <sup>2</sup> S, DSD, TDM	+3.3 and +5	TQFP-64	\$7.95
<b>PCM4202</b>	High-Performance, Stereo Audio ADC, $\Delta\Sigma$	24	118	216	Stereo	Normal, I <sup>2</sup> S, DSD	+3.3 and +5	SSOP-28	\$4.95
<b>PCM4201</b>	Single-Channel, Low-Power ADC	24	112	108	1 Ch	Normal, I <sup>2</sup> S	+3.3 and +5	TSSOP-16	\$2.50
PCM1804	$\Delta\Sigma$ Audio ADC	24	112	192	Stereo	Normal, I <sup>2</sup> S, DSD	+3.3 and +5	SSOP-28	\$5.20
PCM1850/1	Stereo Audio ADC with 2 x 6 Input MUX, and PGA, SPI (PCM1850), I <sup>2</sup> C (PCM1851)	24	100	96	Stereo	Normal, I <sup>2</sup> S	+3.3 and +5	TQFP-32	\$4.80
PCM1802	$\Delta\Sigma$ Audio ADC	24	105	96	Stereo	Normal, I <sup>2</sup> S	+3.3 and +5	SSOP-20	\$3.35
PCM1800	CMOS, Multilevel $\Delta\Sigma$	20	95	48	Stereo	Normal, I <sup>2</sup> S	+5	SSOP-24	\$2.60
PCM1801	Low-Cost Audio ADC	16	93	48	Stereo	Normal, I <sup>2</sup> S	+5	SO-14	\$2.40
<b>Codecs</b>									
PCM3010	Audio Stereo Codec, $\Delta\Sigma$	24	104	96/192	Stereo	Left Justified, I <sup>2</sup> S Right Justified	+3.3 and +5	SSOP-24	\$4.00
<b>TLV320AIC32</b>	Low-Power Stereo Codec with Headphone/Speaker Amp	24	103	96	Stereo	Normal, I <sup>2</sup> S, DSP, TDM	+2.7 to 3.6	QFN-32	\$3.45
<b>TLV320AIC33</b>	Low-Power Stereo Codec with Headphone/Speaker Amp	24	103	96	Stereo	Normal, I <sup>2</sup> S, DSP, TDM	+2.7 to 3.6	QFN-48 BGA-80	\$3.95
<b>PCM3052A</b>	High-Performance Stereo Codec with Mic Preamp, MUX, Volume Control	24	100	96	Stereo	I <sup>2</sup> S	+3.3 and +5	VQFN-32	TBD
TLV320AIC28/29	Low-Power Codec with Headphone Amp AIC Differential	24	97	96	Stereo	Left Justified, I <sup>2</sup> S Right Justified	+1.5 to 3.3	SSOP-28	\$3.45
<b>TLV320AIC26</b>	Low-Power, Low-Cost Codec with Headphone/Speaker Amp	24	97	53	Mono/Stereo	Left Justified, I <sup>2</sup> S, Right Justified, DSP	+2.7 to 3.6	QFN-32	\$3.25
<b>TLV320AIC28</b>	Low-Power Codec with Headphone/Speaker Amp	24	95	53	Mono/Stereo	Left Justified, I <sup>2</sup> S, Right Justified, DSP	3.0 to 3.6	QFN-48	\$3.95

\*Suggested resale price in U.S. dollars in quantities of 1,000.

New products are listed in bold red. Preview products appear in bold blue.

## Digital Audio Interface Products and Asynchronous Sample Rate Converters

Device	Description	Dynamic Range (dB)	THD+N (dB)	Input/Output Sampling Rate (kHz) max	Control Mode	Audio Data Format	Power Supply (V)	Package	Price*
<b>Asynchronous Sample Rate Converters (ASRC)</b>									
<b>SRC4194</b>	Highest-Performance 4-Channel ASRC	144	-140	212	S/W (SPI), H/W	Normal, I <sup>2</sup> S, TDM	+1.8 or +3.3	TQFP-64	\$14.95
SRC4193	Highest-Performance Stereo ASRC	144	-140	212	S/W (SPI)	Normal, I <sup>2</sup> S, TDM	+3.3	SSOP-28	\$8.50
SRC4192	Highest-Performance Stereo ASRC	144	-140	212	H/W	Normal, I <sup>2</sup> S, TDM	+3.3	SSOP-28	\$8.50
<b>SRC4184</b>	4-Channel ASRC	128	-125	212	S/W (SPI), H/W	Normal, I <sup>2</sup> S, TDM	+1.8 or +3.3	TQFP-64	\$8.50
SRC4190	Stereo ASRC	128	-125	212	H/W	Normal, I <sup>2</sup> S, TDM	+3.3	SSOP-28	\$4.50
<b>SRC4392</b>	Combo ASRC (DIR+SRC+DIT)	144	-140	216	S/W (SPI/I <sup>2</sup> C)	Normal, I <sup>2</sup> S, TDM	+1.8 and +3.3	TQFP-48	\$14.95
<b>SRC4382</b>	Combo ASRC (DIR+SRC+DIT)	128	-125	216	S/W (SPI/I <sup>2</sup> C)	Normal, I <sup>2</sup> S, TDM	+1.8 and +3.3	TQFP-48	\$9.95
<b>Digital Interface</b>									
DIT4096	Digital Audio Interface Transmitter	—	—	96	S/W (SPI), H/W	AES/EBU, S/PDIF	+3.3 and +5	TSSOP-28	\$1.55
DIT4192	Digital Audio Interface Transmitter	—	—	192	S/W (SPI), H/W	AES/EBU, S/PDIF	+3.3 and +5	TSSOP-28	\$2.05
<b>DIX4192</b>	Transceiver (DIR + DIT)	—	—	192	S/W (SPI), H/W	AES/EBU, S/PDIF	+1.8 and +3.3	TQFP-48	\$5.95

\*Suggested resale price in U.S. dollars in quantities of 1,000.

New products are listed in bold red.

## Audio DACs and ADCs and Touch Screen Controllers

## Audio Support Products Selection Guide

Device	Description	Resolution (Bits) (max)	Dynamic Range (dB)	Sampling Rate (kHz) (max)	Config.	Audio Data Format	Power Supply (V)	Package	Price*
<b>Digital Filters</b>									
DF1704	Digital Interpolation Filter	24	N/A	96	Stereo	Normal, I <sup>2</sup> S	+5	SSOP-28	\$10.60
DF1706	Digital Interpolation Filter	24	N/A	192	Stereo	Normal, I <sup>2</sup> S	+3.3	SSOP-28	\$11.65
<b>PLLs</b>									
PLL1700	Multi-Clock Generator	—	150	96	—	—	+3.3 or +5	SSOP-20	\$2.40
PLL1705	Dual PLL Multi-Clock Generator	—	50	96	—	Parallel Control	+3.3	SSOP-20	\$1.30
PLL1706	Dual PLL Multi-Clock Generator	—	50	96	—	Serial Control	+3.3	SSOP-20	\$1.30

\*Suggested resale price in U.S. dollars in quantities of 1,000.

## Touch Screen Controllers Selection Guide

Device	Touch Panel	Res. (Bits)	Sample Rate (kSPS)	Interface	Features	Audio I/O	V <sub>REF</sub>	Supply Voltage (V)	Package(s)	Price*
<b>Touch Screen Only Parts</b>										
ADS7843	4-Wire	12 (8)	Up to 125	Serial, SPI	X, Y, Aux	—	Ext	+2.7 to +5.25	SSOP-16	\$1.70
ADS7845	5-Wire	12 (8)	Up to 125	Serial, SPI	X, Y, Aux	—	Ext	+2.7 to +5.25	SSOP-16	\$4.20
ADS7846	4-Wire	12 (8)	Up to 125	Serial, SPI	X, Y, Pressure, Aux, V <sub>BAT</sub> , Temp	—	Int	+2.7 to +5.25	SSOP-16, TSSOP-16, QFN-16, BGA-48	\$2.05
TSC2000	4-Wire	8, 10, 12	Up to 125	Serial, SPI	Processor, X, Y, Pressure V <sub>BAT</sub> , Temp, Aux, DAC	—	Int	+2.7 to +3.6	TSSOP-20	\$2.35
TSC2003	4-Wire	12 (8)	Up to 50	Serial, I <sup>2</sup> C	X, Y, Pressure, V <sub>BAT</sub> , Aux, Temp	—	Int	+2.7 to +5.25	TSSOP-16, BGA-48	\$2.25
TSC2046	4-Wire	12, (8)	Up to 125	Serial, SPI	X, Y, Pressure, V <sub>BAT</sub> , Aux, Temp	—	Int	Analog: +2.2 to +5.25 Logic: +1.5 to +5.25	TSSOP-16, QFN-16, BGA-48	\$1.80
TSC2200	4-Wire	8, 10, 12	Up to 125	Serial, SPI	Processor, X, Y, Pressure V <sub>BAT</sub> , Temp, KP, Aux, DAC	—	Int	+2.7 to +3.6	TSSOP-28, QFN-32	\$2.40
<b>TSC2005</b>	4-wire	10, 12	Up to 200	Serial, SPI	X, Y, Pressure, Fully Programmable, Temp Pre-Processing, SHDN	—	Ext	+1.6 to +3.6	WCSP-18	\$2.15

## Touch Screen + Audio Parts

Device	Description	Resolution (Bits) (max)	Dynamic Range (dB)	Sampling Rate (kHz) (max)	Configuration	Audio Data Format	Power Supply (V)	Package(s)	Price*
TSC2101	Low-Power Codec with HP/Speaker Amp & Touch-Screen Controller	12	95	125	Mono/Stereo	Left Justified, I <sup>2</sup> S,	+3.0 to 3.6	QFN-48	\$4.95
<b>TSC2111</b>	Touch-Screen Controller TSC2111-Differential	12	95	125	Mono/Stereo	Right Justified, DSP	+2.7 to 3.6	QFN-48	TBD
TSC2100	Low-Power, Low-Cost Codec, Amp & Touch-Screen Controller	24	97	53	Mono/Stereo	Left Justified, I <sup>2</sup> S, Right Justified, DSP	+2.7 to 3.6	QFN-32, TSSOP-32	\$3.95
TSC2102	Low-Power, Low-Cost DAC, Amp & Touch-Screen Controller	24	97	53	Stereo	Left Justified, I <sup>2</sup> S, Right Justified, DSP	+2.7 to 3.6	QFN-32	\$3.70
PCM3002/03	Low-Power Codec, S/W (PCM3002), H/W (PCM3003)	20	94	48	Stereo	Normal, I <sup>2</sup> S	+2.7 to 3.6	SSOP-24	\$3.45
TSC2301	Low-Power Codec with Headphone Amp & Touch-Screen Controller	20	98	48	Stereo	Normal, I <sup>2</sup> S	+2.7 to 3.6	TQFP-64, BGA-120	\$4.95
TSC2302	Low-Power Codec w/Headphone Amp, Keypad & Touch-Screen Controller	20	98	48	Stereo	Normal, I <sup>2</sup> S	+2.7 to 3.6	QFN-48	\$4.50
PCM3000/1	Stereo Audio Codec, S/W (PCM3000), H/W (PCM3001)	18	96	48	Stereo	Normal, I <sup>2</sup> S	+5	SSOP-28	\$3.45
TLV320AIC31	Low Power Stereo Codec w/Stereo HP Amp, 4 Inputs/6 Outputs	24	103	96	Stereo	Normal, I <sup>2</sup> S, DSP, TDM	+2.7 to 3.6	QFN-32	\$3.45
PCM3008	Low-Power, Low-Cost Codec	16	88	48	Stereo	Normal, I <sup>2</sup> S	+2.1 to 3.6	SSOP-16	\$3.10
PCM3006	Stereo Audio Codec	16	93	48	Stereo	Normal	+2.7 to 3.6	SSOP-24	\$3.45
PCM3500/1	Voice/Modem Mono Codec	16	88	26	Mono	DSP	+2.7 to 3.6	SSOP-24	\$2.65
PCM3792	Portable Stereo Codec w/Integrated Class-D Amp	24	95	90	Stereo	Normal	+2.7 to 3.6	BGA-96	\$3.60
TSC2300	4-Wire Touch Screen Interface, Stereo DAC Mono ADC, Integrated PLL	20	98	48	Mono/Stereo	Normal, I <sup>2</sup> S	+2.7 to 3.6	TQFP-64	\$4.75

\*Suggested resale price in U.S. dollars in quantities of 1,000.

Preview products appear in bold blue.

## TINA-Spice Module



### SPICE-Based Analog Simulation Program

TI is pleased to announce TINA-TI™, an easy-to-use, but powerful, circuit simulation program based on a SPICE engine. Created exclusively for TI by DesignSoft, TINA-TI is a modified version of the feature rich TINA simulation program.

TINA-TI is a fully functional version of TINA, downloadable from the TI website and loaded with a library of TI macromodels plus passive and active models and is a fast and easy way to get started with circuit simulation. To simplify the design process, many application schematics are available for download and simulation that make excellent starting points for personalized simulation. TINA-TI provides all the conventional DC,

transient and frequency domain analysis of SPICE and much more.

TINA-TI has extensive post processing capability that allows you to format results the way you want them. Virtual instruments allow you to select input waveforms and probe circuit nodes voltages and waveforms. TINA's

schematic drawing and capture is truly intuitive—a real "quickstart." TINA-TI is limited to circuits with two ICs and up to 20 additional nodes, and is available at [www.ti.com/tina-ti](http://www.ti.com/tina-ti)

### TINA-TI™ Spice Program

#### TINA-TI Features:

- Intuitive schematic editor
- TI macromodels installed, ready to use
- Circuit examples for each macromodel
- Bode plots, transient, noise analysis and much more
- Easy-to-use virtual instruments

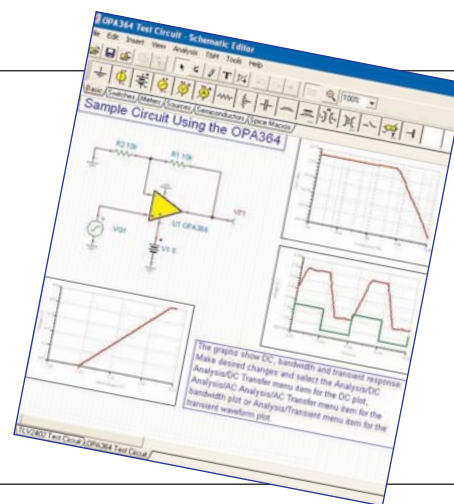



### Amplifier Evaluation Modules

To ease and speed the design process, TI offers evaluation modules (EVMs) for many amplifiers and other analog products. EVMs contain an evaluation board, product data sheet and user's guide.

To find specific EVMs, visit [amplifier.ti.com/evm](http://amplifier.ti.com/evm) or the Development Tools section of any individual product folder (below).

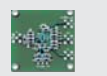
### [amplifier.ti.com/evm](http://amplifier.ti.com/evm)

Hardware Tools	High-Speed Operational Amplifiers		Audio Power Operational Amplifiers	Amplifiers
	Development Boards/EVMs	✓ Fully-Populated Ready-to-Use 	✓ Unpopulated Ready-to-Use 	✓ Universal Amplifier Boards 

Every high-speed and audio power amplifier has a fully populated, ready-to-use EVM available or an unpopulated PCB (printed circuit board) for evaluation of the various models. Populated evaluation boards are also available for selected other TI amplifiers. Please see the individual device product folder on the TI website or contact your local TI sales office for additional choices and availability.

Universal op amp EVMs are unpopulated printed circuit boards that eliminate the need for dual in-line samples in the evaluation of TI amplifiers. These boards feature:

- Various packages and shutdown
- The ability to evaluate single, dual, or quad amps on several eval spaces per board

- Detachable circuit board development areas for improved portability
- User manuals with complete board schematic, board layout and numerous standard example circuits
- Product-level macromodels, designed for use with SPICE, allow efficient simulation of complex circuits without having to use transistor-level models. Download individual models at [amplifier.ti.com/spice](http://amplifier.ti.com/spice)

To order your universal op amp EVMs, contact the nearest Product Information Center (PIC) listed on page 115.

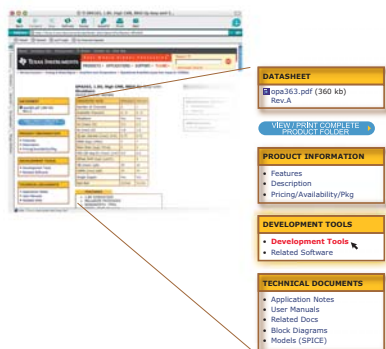

## → Signal Chain Prototyping System

### Use modular Evaluation Modules (EVMs) to prototype a complete data acquisition system in minutes!

Imagine being able to prototype your entire signal chain—input signal conditioning, A/D conversion, processor, D/A conversion and output signal conditioning—with simple building blocks. Imagine not having to lay out a printed circuit board just to evaluate a system signal processing idea.

With TI's modular EVM building blocks, you can put together a complete data acquisition system featuring signal conditioning, an A/D converter and a processor—all in just a few minutes. For a more complete system you can add on from there—a D/A converter, or more output signal conditioning. With modular EVM boards that go together easily thanks to standardized connectors, you can quickly build a complete hardware prototype and get to writing your application code faster.

You can also build your own modules to fit this system, to accommodate circuits that may not be available directly from TI. Refer to the links at the end of this guide to find out how the system is defined. Get More Information:

**Modular EVM Design Guidelines at:**  
<http://www-s.ti.com/sc/psheets/slaa185/slaa185.pdf>

**Get More Information on Modular EVM Listings at:** [http://www.ti-estore.com/Merchant2/compatible-DSP\\_Analog.htm](http://www.ti-estore.com/Merchant2/compatible-DSP_Analog.htm)

### Start with the Processor

The processor is the heart of your system. Do you need the power of a DSP, or the features of a microcontroller? You're free to choose and explore these options with the modular EVM system. The signal chain building blocks have the ability to easily snap into place on an interface card to connect them to most of TI's DSPs.

Don't need a DSP? TI's ultra-low-power MSP430 microcontroller products and MicroSystem Controllers feature built-in analog functionality. In many systems, external data conversion components may

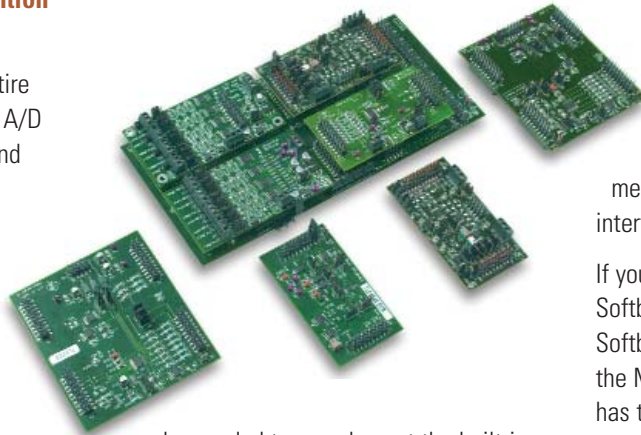

be needed to complement the built-in functions. For those cases, our broad range of data conversion products can be used with these microcontrollers.

Using FPGAs instead of a processor? Some distributors of FPGAs have developed interface boards that allow the signal chain building blocks to connect to their FPGA development systems.

If you just want to evaluate the device on the EVM using standard lab equipment, or want to try wiring the board into your existing system, the modular EVMs will allow for that as well, no processor needed. You have access to all the essential interface pins on the device through the standardized connectors. So no matter how you process the data, we've got a way to help you develop your system.

### Ready to Get Started?

If you've decided to use a DSP in your system, an interface card may be required to connect your DSP Starter Kit (DSK) to the modular EVMs. Refer to the table at the end of this article to see which interface is required for your DSK. A listing of EVMs compatible with our DSKs can be found on the TI eStore. [www.ti-estore.com](http://www.ti-estore.com)

If the MSP430 microcontroller is what you're using the Softbaugh™ HPA449 board is a complete MSP430 development system which features sites into which you can connect the modular EVMs. A listing of EVMs compatible with our microcontroller products can be found on the TI eStore.

### Developing with Modular EVMs

Developing software with the modular EVMs is easy. If you're using a DSP, our free Data Converter Support Plug-In for Code Composer Studio™ Studio integrated development environment (IDE) can help you set up the DSP to interface with the data converters.

If you're developing MSP430 code with Softbaugh's HPA449, you can use any of Softbaugh's tools to download programs to the MSP430's Flash. The HPA449 board also has the ability to program the Flash through the serial port using open-source programs to download your hex code to the HPA449's MSP430F449 processor.

### Code Examples

Code for use with the modular EVMs on the different platforms can be found in the tool folder for the EVM. Look for the Related Software section in Related Documents in the tool folder. Very often, this code is a simple project that runs on the processor used; in some cases, complete software to evaluate data converters that runs on your PC is included as well.

The data converter support plug-in residing in TI's Code Composer Studio IDE makes it easier than ever to design with TI data converter products along with TI's TMS320™ digital signal processors (DSPs).

Using the free tool in the Code Composer Studio IDE reduces the time required to configure data converters by up to 90 percent. The plug-in software module generates initialization data and interface software for the user's data converter/DSP combination using a graphical user interface, along with the necessary data structures. For many data converter EVMs and DSP Starter Kit (DSK) combinations, complete software examples containing source code and pre-coded executables to run the data converter are available. The software examples show how to design with the data converter by using the interface software generated by the data converter plug-in module (DCP).





### Software Saves Configuration Time

Today, state-of-the-art data converters are highly integrated, requiring configuration for input channel selection, filters, interfaces, adjustable gain control, offset cancellation, integrated first-in-first-out (FIFO) memory and other features. Creating data converter interface software can complicate the development effort. TI data converters and the interface software simplify the software development task, reducing time-to-market for applications using TI DSPs.

The DCP is a component of TI's industry-leading Code Composer Studio IDE and offers easy-to-use windows for "point-and-click" configuration, preventing illegal combinations of settings. The DCP automatically creates the interface software as the C source code necessary to use the data converter, then inserts the code into the existing user project. The created files contain the functions necessary to initialize the data converter, read/write sample values and to perform special functions (like power-down).

### Innovations in Design Support

TI merges DSP hardware, DSP software and data converters to simplify the design process with a comprehensive DSP solution that includes peripherals.

Support is available for data converters used with TI's C28x™, C54x™, C55x™, C62x™, C64x™ and C67x™ DSP generations.

The easy-to-use support software benefits developers of wireless data networking, portable audio, voice-over-packet, digital imaging, speech, motor control and a wide range of other advanced DSP-based applications.

The software has been fully tested in conjunction with the DSK and the data converter EVMs. Help files are included along with the data converter information in the plug-in module. These features minimize risk and ease the learning curve so the DSP designers can start system development quickly, concentrating their efforts in areas of product innovation to improve the value of their intellectual property and get the greatest return of investment.

### Using TI's Data Converter Interface Software

TI is committed to complementing its DSPs with a full range of data converters. Interface software for new DSP-optimized TI data converter products is planned, including DACs and ADCs, as well as codecs and selected special function devices.

The DCP module and the already available data converter software for more than 125 data converters is included with the Code Composer Studio IDE. To order Code Composer Studio IDE, visit our web page at [dspvillage.ti.com](http://dspvillage.ti.com).

As new interface software is developed, it will be made available as part of the DCP module. The new versions can be downloaded and installed in the Code Composer Studio IDE, versions 2.0 and higher.

Updates to the DCP module can be downloaded free of charge from [www.ti.com/dcplug-in](http://www.ti.com/dcplug-in)

## Use modular evaluation modules to prototype a complete data acquisition system in minutes!

Imagine being able to prototype your entire signal chain—input signal conditioning, A/D conversion, processor, D/A conversion, and output signal conditioning—with simple building blocks. Imagine not having to lay out a printed circuit board just to evaluate a system signal processing idea. With TI's modular EVM building blocks, you can put together a complete data acquisition system featuring signal conditioning, an A/D converter and a processor—all in just a few minutes. For a more complete system you can add on from there—a D/A converter, or more output signal conditioning. The modular EVM boards go together easily thanks to standardized connectors, you can quickly build a complete hardware prototype and get to writing your application code faster.

#### Modular EVM Design Guidelines

[www.s.ti.com/sc/psheets/slaa185/slaa185.pdf](http://www.s.ti.com/sc/psheets/slaa185/slaa185.pdf)

#### Code Composer Studio™ IDE

<http://dspvillage.ti.com>

#### TI e-store

[www.ti-estore.com](http://www.ti-estore.com)

#### Modular EVM Listing

[www.ti-estore.com/Merchant2/compatible-DSP\\_Analog.htm](http://www.ti-estore.com/Merchant2/compatible-DSP_Analog.htm)

#### Data Converter Support Tool

[www.ti.com/dcplug-in](http://www.ti.com/dcplug-in)

#### HPA449

[www.softbaugh.com/ProductPage.cfm?strPartNo=HPA449](http://www.softbaugh.com/ProductPage.cfm?strPartNo=HPA449)



## ➔ Data Converter Plug-In (DCP) for Code Composer Studio™ IDE

TI's Data Converter Plug-In (DCP) is a free development tool that allows the creation of initialization data and configuration software for TI data converters from within the Integrated Development Environment (IDE) of Code Composer Studio™. It provides easy-to-use windows for "point-and-click" data converter configuration from within the IDE, preventing illegal combinations of settings. The DCP dialog allows the user to select all the different settings for the data converter from a single screen and to automatically generate the interface software with a

single mouse click. The generated well-documented C source files contain all functions necessary to talk to the external data converter and to set up all of the registers internal to this device. The minimum function set includes read/write functions (single words and blocks of data), initialization functions and data structures and some device-specific functions like power down.

The generated code is to a great extent hardware independent, so it can be used together with the analog evaluation

modules (EVMs) from our modular EVM system, our DSP Starter Kits (DSKs) or with your own custom board.

To download your free 3.70 version of the Data Converter Plug-In for Code Composer Studio IDE, please go to:

[www.ti.com/dcplug-in](http://www.ti.com/dcplug-in)

New devices are added to the tool on a regular basis.

## Data Converter Support Tool (DCP) for Code Composer Studio™ IDE

### Supported Devices in Version 3.70

Device	Description	C28x™	C54x™	C55x™	C6000™	C64x™
<b>ADC:</b>						
ADS1216	24-Bit, 8-Channel, 0.78kSPS , 5V		✓	✓	✓	
ADS1217	24-Bit, 8-Channel, 0.78kSPS , 3.3V		✓	✓	✓	
ADS1218	24-Bit, 8-Channel, 0.78kSPS , with FLASH		✓	✓	✓	
ADS1240	24-Bit, 4-Channel, 15SPS		✓		✓	
ADS1241	24-Bit, 8-Channel, 15SPS		✓		✓	
ADS1251	24-Bit, 1-Channel (diff), 20kSPS		✓	✓	✓	
ADS1252	24-Bit, 1-Channel (diff), 40kSPS		✓	✓	✓	
ADS1253	24-Bit, 4-Channel (diff), 20kSPS , 1.8-3.6V		✓		✓	
ADS1254	24-Bit, 4-Channel (diff), 40kSPS , 5V		✓		✓	
ADS1271	24-Bit, 1-Channel, 105kSPS				✓ <sup>1</sup>	
ADS1601	16-Bit, 1-Channel, 1.25MSPS			✓ <sup>1</sup>	✓ <sup>1</sup>	✓ <sup>1</sup>
ADS1602	16-Bit, 1-Channel, 2.5MSPS			✓ <sup>1</sup>	✓ <sup>1</sup>	✓ <sup>1</sup>
ADS1605	16-Bit, 1-Channel (diff), 5MSPS , 3.3V I/O, 5V Analog			✓ <sup>1</sup>	✓ <sup>1</sup>	✓ <sup>1</sup>
ADS1606	16-Bit, 1-Channel (diff), 5MSPS , 16 Word FIFO			✓ <sup>1</sup>	✓ <sup>1</sup>	✓ <sup>1</sup>
ADS1610	16-Bit, 1-Channel (diff), 10MSPS , 3.3V I/O, 5V Analog			✓ <sup>1</sup>	✓ <sup>1</sup>	✓ <sup>1</sup>
ADS1625	18-Bit, 1-Channel (diff), 1.25MSPS , 3.3V I/O, 5V Analog			✓ <sup>1</sup>	✓ <sup>1</sup>	✓ <sup>1</sup>
ADS1626	18-Bit, 1-Channel (diff), 1.25MSPS , 16 Word FIFO			✓ <sup>1</sup>	✓ <sup>1</sup>	✓ <sup>1</sup>
ADS7804	12-Bit, 1-Channel, 100kSPS , ±10V Input Range	✓	✓	✓ <sup>1</sup>	✓ <sup>1</sup>	✓ <sup>1</sup>
ADS7805	16-Bit, 1-Channel, 100kSPS , ±10V Input Range	✓	✓	✓ <sup>1</sup>	✓ <sup>1</sup>	✓ <sup>1</sup>
ADS7841	12-Bit, 4-Channel, 200kSPS		✓ <sup>1</sup>			
ADS7844	12-Bit, 8-Channel, 200kSPS		✓ <sup>1</sup>			
ADS7861	12-Bit, 2+2-Channel, 500kSPS , Simultaneous Sampling	✓	✓	✓	✓	✓
ADS7864	12-Bit, 3x2-Channels, 500kSPS , Simultaneous Sampling	✓		✓ <sup>1</sup>	✓ <sup>1</sup>	✓ <sup>1</sup>

<sup>1</sup>With (E)DMA support

#### Remarks

- C28x:** A check-mark in this column indicates that the data converter support tool generates a full driver for the TMS320C2800 family, which not only configures the data converter, but also the peripheral the device is connected to (e.g. the serial port or the memory interface). If no check-mark is present, only the register settings, but no interface functions are generated.
- C54x:** A check-mark in this column indicates that the data converter support tool generates a full driver for the TMS320C5400 family, which not only configures the data converter, but also the peripheral the device is connected to (e.g. the serial port or the memory interface). If no check-mark is present, only the register settings, but no interface functions are generated.
- C55x:** A check-mark in this column indicates that the data converter support tool generates a full driver for the TMS320C5500 family, which not only configures the data converter, but also the peripheral the device is connected to (e.g. the serial port or the memory interface). If no check-mark is present, only the register settings, but no interface functions are generated.
- C6000:** A check-mark in this column indicates that the data converter support tool generates a full driver for the TMS320C6200/C6700 family, which not only configures the data converter, but also the peripheral the device is connected to (e.g. the serial port or the memory interface). If no check-mark is present, only the register settings, but no interface functions are generated.
- C64x:** A check-mark in this column indicates that the data converter support tool generates a full driver for the TMS320C6400 family, which not only configures the data converter, but also the peripheral the device is connected to (e.g. the serial port or the memory interface). If no check-mark is present, only the register settings, but no interface functions are generated.

The online version of this table can be found at: [www.ti.com/dcplug-in](http://www.ti.com/dcplug-in)



## Data Converter Plug-In (DCP) for Code Composer Studio™ IDE



Device	Description	C28x™	C54x™	C55x™	C6000™	C64x™
ADS7881	12-Bit, 1-Channel, 4MSPS, Int. Reference			✓ <sup>1</sup>	✓ <sup>1</sup>	✓ <sup>1</sup>
ADS7891	14-Bit, 1-Channel, 3MSPS, Int. Reference			✓ <sup>1</sup>	✓ <sup>1</sup>	✓ <sup>1</sup>
ADS803	12-Bit, 1-Channel, 5MSPS			✓ <sup>1</sup>	✓ <sup>1</sup>	✓ <sup>1</sup>
ADS804	12-Bit, 1-Channel, 10MSPS			✓ <sup>1</sup>	✓ <sup>1</sup>	✓ <sup>1</sup>
ADS805	12-Bit, 1-Channel, 20MSPS			✓ <sup>1</sup>	✓ <sup>1</sup>	✓ <sup>1</sup>
ADS8320	16-Bit, 1-Channel, 100kSPS, 2.7-5.25V	✓	✓	✓ <sup>1</sup>	✓ <sup>1</sup>	✓ <sup>1</sup>
ADS8321	16-Bit, 1-Channel, 100kSPS, 4.75-5.25V	✓	✓	✓ <sup>1</sup>	✓ <sup>1</sup>	✓ <sup>1</sup>
ADS8322	16-Bit, 1-Channel (diff), 500kSPS, 5V			✓ <sup>1</sup>	✓ <sup>1</sup>	✓ <sup>1</sup>
ADS8323	16-Bit, 1-Channel (diff), 500kSPS, 5V			✓ <sup>1</sup>	✓ <sup>1</sup>	✓ <sup>1</sup>
ADS8324	14-Bit, 1-Channel, 50kSPS, 1.8-3.6V	✓	✓	✓ <sup>1</sup>	✓ <sup>1</sup>	✓ <sup>1</sup>
ADS8325	16-Bit, 1-Channel, 100kSPS, 2.7-5.5V	✓	✓	✓ <sup>1</sup>	✓ <sup>1</sup>	✓ <sup>1</sup>
ADS8361	16-Bit, 2+2- Channel, 500kSPS, Simultaneous Sampling	✓	✓	✓	✓	✓
ADS8364	16-Bit, 6-Channel, 250kSPS		✓		✓	✓
ADS8370	16-Bit, 1-Channel, 600kSPS, Unipolar Pseudo Diff, Int. Reference			✓ <sup>1</sup>	✓ <sup>1</sup>	✓ <sup>1</sup>
ADS8371	16-Bit, 1-Channel, 750kSPS, Unipolar Input microPower			✓ <sup>1</sup>	✓ <sup>1</sup>	✓ <sup>1</sup>
ADS8372	16-Bit, 1-Channel (diff), 600kSPS, Pseudo Bipolar, Int. Reference			✓ <sup>1</sup>	✓ <sup>1</sup>	✓ <sup>1</sup>
ADS8380	1-Bit, 1-Channel, 600kSPS, Unipolar Pseudo Diff, Int. Reference			✓ <sup>1</sup>	✓ <sup>1</sup>	✓ <sup>1</sup>
ADS8381	18-Bit, 1-Channel, 580kSPS			✓ <sup>1</sup>	✓ <sup>1</sup>	✓ <sup>1</sup>
ADS8382	18-Bit, 1-Channel (diff), 600kSPS, Pseudo Bipolar, Int. Reference			✓ <sup>1</sup>	✓ <sup>1</sup>	✓ <sup>1</sup>
ADS8383	18-Bit, 1- Channel, 500kSPS			✓ <sup>1</sup>	✓ <sup>1</sup>	✓ <sup>1</sup>
ADS8401	16-Bit, 1-Channel, 1.25MSPS, Unipolar Input	✓		✓ <sup>1</sup>	✓ <sup>1</sup>	✓ <sup>1</sup>
ADS8402	16-Bit, 1-Channel, 1.25MSPS, Bipolar Input	✓		✓ <sup>1</sup>	✓ <sup>1</sup>	✓ <sup>1</sup>
ADS8411	16-Bit, 1-Channel, 2MSPS, Unipolar Input			✓ <sup>1</sup>	✓ <sup>1</sup>	✓ <sup>1</sup>
ADS8412	16-Bit, 1-Channel, 2MSPS, Bipolar Input			✓ <sup>1</sup>	✓ <sup>1</sup>	✓ <sup>1</sup>
ADS8504	12-Bit, 1-Channel, 250kSPS, ±10V Input Range	✓	✓	✓ <sup>1</sup>	✓ <sup>1</sup>	✓ <sup>1</sup>
ADS8505	16-Bit, 1-Channel, 250kSPS, ±10V Input Range	✓	✓	✓ <sup>1</sup>	✓ <sup>1</sup>	✓ <sup>1</sup>
PCM1804	24-Bit, Stereo, 192kHz, Audio ADC		✓	✓	✓ <sup>1</sup>	✓ <sup>1</sup>
PCM4202	24-Bit, Stereo, 192kHz, Audio ADC		✓	✓	✓ <sup>1</sup>	✓ <sup>1</sup>
PCM4204	24-Bit, 4-Channel, 216kHz, Audio ADC				✓ <sup>1</sup>	
THS10064	10-Bit, 4-Channel, 6MSPS, 16 Word FIFO	✓	✓	✓ <sup>1</sup>	✓ <sup>1</sup>	✓ <sup>1</sup>
THS1007	10-Bit, 4-Channel, 8MSPS					
THS10082	10-Bit, 2-Channel, 8MSPS, 16 Word FIFO	✓	✓	✓ <sup>1</sup>	✓ <sup>1</sup>	✓ <sup>1</sup>
THS1009	10-Bit, 2-Channel, 8MSPS					
THS1206	12-Bit, 4-Channel, 6MSPS, 16 Word FIFO	✓	✓	✓ <sup>1</sup>	✓ <sup>1</sup>	✓ <sup>1</sup>
THS1207	12-Bit, 4-Channel, 8MSPS					
THS12082	12-Bit, 2-Channel, 8MSPS, 16 Word FIFO	✓	✓	✓ <sup>1</sup>	✓ <sup>1</sup>	✓ <sup>1</sup>
TLC1514	10-Bit, 4- Channel, 400kSPS		✓ <sup>1</sup>			

<sup>1</sup>With (E)DMA support

## Remarks

- C28x:** A check-mark in this column indicates that the data converter support tool generates a full driver for the TMS320C2800 family, which not only configures the data converter, but also the peripheral the device is connected to (e.g. the serial port or the memory interface). If no check-mark is present, only the register settings, but no interface functions are generated.
- C54x:** A check-mark in this column indicates that the data converter support tool generates a full driver for the TMS320C5400 family, which not only configures the data converter, but also the peripheral the device is connected to (e.g. the serial port or the memory interface). If no check-mark is present, only the register settings, but no interface functions are generated.
- C55x:** A check-mark in this column indicates that the data converter support tool generates a full driver for the TMS320C5500 family, which not only configures the data converter, but also the peripheral the device is connected to (e.g. the serial port or the memory interface). If no check-mark is present, only the register settings, but no interface functions are generated.
- C6000:** A check-mark in this column indicates that the data converter support tool generates a full driver for the TMS320C6200/C6700 family, which not only configures the data converter, but also the peripheral the device is connected to (e.g. the serial port or the memory interface). If no check-mark is present, only the register settings, but no interface functions are generated.
- C64x:** A check-mark in this column indicates that the data converter support tool generates a full driver for the TMS320C6400 family, which not only configures the data converter, but also the peripheral the device is connected to (e.g. the serial port or the memory interface). If no check-mark is present, only the register settings, but no interface functions are generated.

The online version of this table can be found at: [www.ti.com/dcplug-in](http://www.ti.com/dcplug-in)

 **Data Converter Plug-In (DCP) for Code Composer Studio™ IDE**

Device	Description	C28x™	C54x™	C55x™	C6000™	C64x™
TLC1518	10-Bit, 8-Channel, 400kSPS		✓ <sup>1</sup>			
TLC2551	12-Bit, 1-Channel, 400kSPS, 5V		✓			
TLC2552	12-Bit, 2-Channel, 175kSPS, 5V		✓			
TLC2554	12-Bit, 4-Channel, 400kSPS		✓ <sup>1</sup>			
TLC2555	12-Bit, 1-Channel, 175kSPS, 5V		✓			
TLC2558	12-Bit, 8-Channel, 400kSPS		✓ <sup>1</sup>			
TLC2574	12-Bit, 4-Channel, 200kSPS, 5V		✓			
TLC2578	12-Bit, 8-Channel, 200kSPS, 5V		✓			
TLC3541	14-Bit, 1-Channel, 200kSPS, 5V		✓		✓	
TLC3544	14-Bit, 4-Channel, 200kSPS, 5V		✓			
TLC3545	14-Bit, 1-Channel (diff), 200kSPS, 5V		✓		✓	
TLC3548	14-Bit, 8-Channel, 200kSPS, 5V		✓			
TLC3574	14-Bit, 4-Channel, 200kSPS, 5V		✓			
TLC3578	14-Bit, 8-Channel, 200kSPS, 5V		✓			
TLC4541	16-Bit, 1-Channel, 200kSPS, 5V		✓		✓	
TLC4545	16-Bit, 1-Channel (diff), 200kSPS, 5V		✓		✓	
TLV1504	10-Bit, 4-Channel, 200kSPS		✓		✓	
TLV1508	10-Bit, 8-Channel, 200kSPS		✓		✓	
TLV1570	10-Bit, 8-Channel, 1.25MSPS		✓			
TLV1571	10-Bit, 1-Channel, 1.25MSPS		✓		✓ <sup>1</sup>	
TLV1572	10-Bit, 1-Channel, 1.25MSPS, 2.5-5.5V		✓			
TLV1578	10-Bit, 8-Channel, 1.25MSPS		✓		✓ <sup>1</sup>	
TLV2541	12-Bit, 1-Channel, 200kSPS, 2.7-5.5V		✓			
TLV2542	12-Bit, 2-Channel, 140-200kSPS, 2.7-5.5V		✓			
TLV2544	12-Bit, 4-Channel, 200kSPS		✓		✓ <sup>1</sup>	
TLV2545	12-Bit, 1-Channel, 140-200kSPS, 2.7-5.5V		✓			
TLV2548	12-Bit, 8-Channel, 200kSPS		✓		✓ <sup>1</sup>	
TLV2553	12-Bit, 11-Channel, 200kSPS, 2.7-5V	✓	✓	✓	✓	✓
TLV2556	12-Bit, 11-Channel, 200kSPS, 2.7-5V, Int. Reference	✓	✓	✓	✓	✓
<b>DACs</b>						
DAC7554	12-Bit, 4-Channel, 5µs, 2.7-5.5V	✓	✓ <sup>1</sup>	✓ <sup>1</sup>	✓ <sup>1</sup>	✓ <sup>1</sup>
DAC8501	16-Bit, 1-Channel, 10µs, 2.7-5.5V, MDAC	✓	✓	✓	✓	✓
DAC8531	16-Bit, 1-Channel, 10µs, 2.7-5.5V	✓	✓	✓	✓	✓
DAC8532	16-Bit, 2-Channel, 10µs, 2.7-5.5V	✓	✓	✓	✓	✓
DAC8534	16-Bit, 4-Channel, 10µs, 2.7-5.5V	✓	✓	✓	✓	✓
DAC8580	16-Bit, 1-Channel, 1µs			✓ <sup>1</sup>		
TLC5618A	12-Bit, 2-Channel, 2.5µs, 5V		✓		✓ <sup>2</sup>	

<sup>1</sup>With (E)DMA support <sup>2</sup>These DACs share the same driver, so an additional alignment might be necessary

**Remarks**

- C28x:** A check-mark in this column indicates that the data converter support tool generates a full driver for the TMS320C2800 family, which not only configures the data converter, but also the peripheral the device is connected to (e.g. the serial port or the memory interface). If no check-mark is present, only the register settings, but no interface functions are generated.
- C54x:** A check-mark in this column indicates that the data converter support tool generates a full driver for the TMS320C5400 family, which not only configures the data converter, but also the peripheral the device is connected to (e.g. the serial port or the memory interface). If no check-mark is present, only the register settings, but no interface functions are generated.
- C55x:** A check-mark in this column indicates that the data converter support tool generates a full driver for the TMS320C5500 family, which not only configures the data converter, but also the peripheral the device is connected to (e.g. the serial port or the memory interface). If no check-mark is present, only the register settings, but no interface functions are generated.
- C6000:** A check-mark in this column indicates that the data converter support tool generates a full driver for the TMS320C6200/C6700 family, which not only configures the data converter, but also the peripheral the device is connected to (e.g. the serial port or the memory interface). If no check-mark is present, only the register settings, but no interface functions are generated.
- C64x:** A check-mark in this column indicates that the data converter support tool generates a full driver for the TMS320C6400 family, which not only configures the data converter, but also the peripheral the device is connected to (e.g. the serial port or the memory interface). If no check-mark is present, only the register settings, but no interface functions are generated.

The online version of this table can be found at: [www.ti.com/dcpin](http://www.ti.com/dcpin)

## Data Converter Plug-In (DCP) for Code Composer Studio™ IDE



Device	Description	C28x™	C54x™	C55x™	C6000™	C64x™
TLV5606	10-Bit, 1-Channel, 3µs, 2.7-5.5V		✓		✓ <sup>2</sup>	
TLV5616	12-Bit, 1-Channel, 3µs, 2.7-5.5V		✓		✓ <sup>2</sup>	
TLV5617A	10-Bit, 2-Channel, 2.5µs, 2.7-5.5V		✓		✓ <sup>2</sup>	
TLV5618A	12-Bit, 2-Channel, 2.5µs, 2.7-5.5V		✓		✓ <sup>2</sup>	
TLV5623	8-Bit, 1-Channel, 3µs, 2.7-5.5V		✓		✓ <sup>2</sup>	
TLV5624	8-Bit, 1-Channel, 1µs, 2.7-5.5V, Int. Reference		✓		✓ <sup>2</sup>	
TLV5625	8-Bit, 2-Channel, 2.5µs, 2.7-5.5V		✓		✓ <sup>2</sup>	
TLV5626	8-Bit, 2-Channel, 1µs, 2.7-5.5 V, Int. Reference		✓		✓ <sup>2</sup>	
TLV5636	12-Bit, 1-Channel, 1µs, 2.7-5.5V, Int. Reference		✓		✓ <sup>2</sup>	
TLV5637	10-Bit, 2-Channel, 1µs, 2.7-5.5V, Int. Reference		✓		✓ <sup>2</sup>	
TLV5638	12-Bit, 2-Channel, 1µs, 2.7-5.5V, Int. Reference		✓		✓ <sup>2</sup>	
Codecs						
AIC111	16-Bit, 1-Channel, 40kSPS, 1.3V, microPower		✓			
PCM3002	20-Bit, Stereo, 48kHz		✓		✓	
TLV320AIC10	16-Bit, 1-Channel, 22kSPS, Voiceband Codec		✓		✓	
TLV320AIC11	16-Bit, 1-Channel, 22kSPS, Voiceband Codec, 1.1-3.6V I/O		✓		✓	
TLV320AIC12	16-Bit, 1-Channel, 26/104kSPS, Voiceband Codec		✓	✓	✓	✓
TLV320AIC13	16-Bit, 1-Channel, 26/104kSPS, Voiceband Codec, 1.1V I/O		✓	✓	✓	✓
TLV320AIC14	16-Bit, 1-Channel, 26/104kSPS, Voiceband Codec		✓	✓	✓	✓
TLV320AIC15	16-Bit, 1-Channel, 26/104kSPS, Voiceband Codec, 1.1V I/O		✓	✓	✓	✓
TLV320AIC20	16-Bit, 2-Channel, 26/104kSPS, Voiceband Codec, 3.3V I/O		✓	✓	✓	✓
TLV320AIC21	16-Bit, 1-Channel, 26/104kSPS, Voiceband Codec, 1.1V I/O		✓	✓	✓	✓
TLV320AIC22C	16-Bit, 2-Channel, 16kHz, Dual VOIP Codec		✓	✓	✓	
TLV320AIC23B	24-Bit, Stereo, 96kHz, Stereo Audio Codec		✓ <sup>1</sup>	✓ <sup>1</sup>	✓ <sup>1</sup>	✓ <sup>1</sup>
TLV320AIC24	16-Bit, 1-Channel, 26/104kSPS, Voiceband Codec, 3.3V I/O		✓	✓	✓	✓
TLV320AIC25	16-Bit, 1-Channel, 26/104kSPS, Voiceband Codec, 1.1V I/O		✓	✓	✓	✓
Application Specific						
AFE1230	16-Bit, 1-Channel, 2.5Mbps, G.SHDSL Analog Front End			✓		
AFEDRI8201	16-Bit, 1-Channel, 80MHz, ADC Front End for AM/FM and HD Radios			✓		
AMC7820	12-Bit, 8-Channel, 100kSPS, Analog Monitoring and Control Circuitry		✓		✓	

<sup>1</sup>With (E)DMA support <sup>2</sup>These DACs share the same driver, so an additional alignment might be necessary.

## Remarks

- C28x:** A check-mark in this column indicates that the data converter support tool generates a full driver for the TMS320C2800 family, which not only configures the data converter, but also the peripheral the device is connected to (e.g. the serial port or the memory interface). If no check-mark is present, only the register settings, but no interface functions are generated.
- C54x:** A check-mark in this column indicates that the data converter support tool generates a full driver for the TMS320C5400 family, which not only configures the data converter, but also the peripheral the device is connected to (e.g. the serial port or the memory interface). If no check-mark is present, only the register settings, but no interface functions are generated.
- C55x:** A check-mark in this column indicates that the data converter support tool generates a full driver for the TMS320C5500 family, which not only configures the data converter, but also the peripheral the device is connected to (e.g. the serial port or the memory interface). If no check-mark is present, only the register settings, but no interface functions are generated.
- C6000:** A check-mark in this column indicates that the data converter support tool generates a full driver for the TMS320C6200/C6700 family, which not only configures the data converter, but also the peripheral the device is connected to (e.g. the serial port or the memory interface). If no check-mark is present, only the register settings, but no interface functions are generated.
- C64x:** A check-mark in this column indicates that the data converter support tool generates a full driver for the TMS320C6400 family, which not only configures the data converter, but also the peripheral the device is connected to (e.g. the serial port or the memory interface). If no check-mark is present, only the register settings, but no interface functions are generated.

The online version of this table can be found at: [www.ti.com/dcpug-in](http://www.ti.com/dcpug-in)

## ➔ Amplifier and Signal Processing Application Reports

Title	Lit No.
<b>4-20mA Transmitters</b>	
IC Building Blocks Form Complete Isolated 4-20mA Current-Loop	sboa017
Single Supply 4-20mA Current Loop Receiver	sboa023
Use Low-Impedance Bridges on 4-20mA Current Loop	sboa025
Implementing a 4 mA to 20 mA Current Loop on TI DSPs	szza045
<b>ADC Interfaces</b>	
RLC Filter Design for ADC Interface (Rev. A)	sbaa108a
Design Methodology for MFB Filters in ADC Interface Applications	sboa114
ADS8342 ADC SAR Inputs	sbaa127
Interfacing the VCA8617 with High-Speed ADCs	sbaa130
Interfacing the VCA8613 with High-Speed ADCs	sbaa131
Measuring Single-Ended 0V-5V Signals with Differential Delta-Sigma ADCs	sbaa133
High-Voltage Signal Conditioning for Differential ADCs	sboa096
Amplifiers and Bits: An Introduction to Selecting Amplifiers for Data Conv. (Rev. B)	sloa035b
Buffer Op Amp to ADC Circuit Collection	sloa098
Interfacing op amps and analog-to-digital converters	slyt104
Evaluating operational amplifiers as input amplifiers for A-to-D converters	slyt193
Low-power, high-intercept interface to the ADS5424, 105-MSPS converter	slyt223
Wideband Complementary Current Output DAC Single-Ended Interface	sbaa135
Connecting ADS8410/13 With Long Cable	slaa284
Multiplexing ADS8411	slaa285
<b>Amp/Switched Integrator</b>	
Implementation and Applications of Current Sources and Current Receivers	sboa046
Compensate Transimpedance Amplifiers Intuitively	sboa055
<b>Amplifier and Noise</b>	
Noise Analysis for High-Speed Op Amps	sboa066
Noise Analysis In Operational Amplifier Circuits (Rev. A)	slva043
<b>Amplifier Basics</b>	
Handbook of Operational Amplifier Applications	sboa092A
Understanding Operational Amplifier Specifications	sloa011
Effect of Parasitic Capacitance in Op Amp Circuits (Rev. A)	sloa013
Feedback Amplifier Analysis Tools (Rev. A)	sloa017
Stability Analysis of Voltage-Feedback Op Amps, Including Compensation Technique (Rev. A)	sloa020
Understanding Basic Analog - Active Devices (Rev. A)	sloa026
Understanding Basic Analog Passive Devices	sloa027
Selecting High-Speed Operational Amplifiers Made Easy (Rev. A)	sloa051
DC Parameters: Input Offset Voltage	sloa059
How (Not) To Decouple High-Speed Operational Amplifiers	sloa069
Using a Decompensated Op Amp for Improved Performance	SLYT174
RF and IF Amplifiers with Op Amps	SLYT102
Expanding the Usability of Current-Feedback Amplifiers	SLYT099
Using Texas Instruments SPICE models in PSpice	SLOA070
<b>Audio Amplifiers</b>	
Audio Power Amplifier Solutions for New Wireless Phones	sloa053
Guidelines for Measuring Audio Power Amplifier Performance	sloa068
Calculating Gain for Audio Amplifiers	sloa105A
Measuring Class-D Amplifiers for Audio Speaker Overstress Testing	sloa116
<b>Current-Feedback Amplifiers</b>	
The Current-Feedback Op Amp: A High-Speed Building Block	sboa076
Current Feedback Amps: Review, Stability Analysis, and Applications	sboa081
Stabilizing Current-Feedback Op Amp while optimizing circuit performance using Pspice	sboa095
A Current Feedback Op-Amp Circuit Collection	sloa066
Voltage Feedback vs. Current Feedback Op Amps	slva051
<b>Difference Amplifiers</b>	
Fully-Differential Amplifiers (Rev. D)	sloa054D
A Differential Operational Amplifier Circuit Collection	sloa064
Differential Op Amp Single-Supply Design Techniques	sloa072
Fully-Differential OP Amps Made Easy	sloa099
Active Output Impedance for ADSL Line Drivers	sloa100
Low-Power, High-Intercept Interface to the ADS5424, 105-MSPS Converter	slyt223
Analysis of Fully Differential Amplifiers	slyt157
<b>General Tutorials</b>	
Fully Differential Amplifiers Applications: Line Termination, Driving High-Speed ADCs, and Differential Transmission Lines	slyt143

Title	Lit No.
Understanding Data Converters	slaa013
The Op Amp's Place in the World (Chap. 1)	sloa073
Review of Circuit Theory (Chap. 2)	sloa074
Development of Ideal Op Amp Equations (Chap. 3)	sloa075
Single-Supply Op Amp Design Techniques (Chap. 4)	sloa076
Feedback and Stability Theory (Chap. 5)	sloa077
Development of the Non-Ideal Op Amp Equations (Chap. 6)	sloa078
Voltage Feedback Op Amp Compensation (Chap. 7)	sloa079
Current Feedback Op Amp Analysis (Chap. 8)	sloa080
Voltage and Current-Feedback Op Amp Comparison (Chap. 9)	sloa081
Op Amp Noise Theory and Applications (Chap. 10)	sloa082
Understanding Op Amp Parameters (Chap. 11)	sloa083
Instrumentation: Sensors to A/D Converters (Chap. 12)	sloa084
Wireless Communication Signal Conditioning for IF Sampling (Chap. 13)	sloa085
Interfacing D/A Converters to Loads (Chap. 14)	sloa086
Sine Wave Oscillator (Chap. 15)	sloa087
Active Filter Design Techniques (Chap. 16)	sloa088
Circuit Board Layout Techniques (Chap. 17)	sloa089
Designing Low-Voltage Op Amp Circuits (Chap. 18)	sloa090
Single-Supply Circuit Collection (Appendix A)	sloa091
Op Amps for Everyone Design Guide and Excerpts	sloa006b
Introduction to phase-locked loop system modeling	slyt169
<b>Instrumentation Amplifiers</b>	
AC Coupling Instrumentation and Difference Amplifiers	sboa003
Programmable-Gain Instrumentation Amplifiers	sboa024
Precision Absolute Value Circuits	sboa068
Signal Conditioning Wheatstone Resistive Bridge Sensors	sloa034
Getting the Most Out of Your Instrumentation Amplifier Design	slyt226
PGA309 Quick Start System Reference Guide	sboa103C
<b>Isolation Amplifiers</b>	
Composite Op Amp Gives You The Best of Both Worlds	sboa002
Isolation Amps Hike Accuracy and Reliability Composite Amplifier	sboa064
<b>Layout</b>	
Measuring Board Parasitics in High-Speed Analog Design	sboa094
NanoStar™ & NanoFree™ 300_μm Solder Bump WCSP Application	sbva017
PowerPAD™ Thermally Enhanced Package Application Report	slma002
High-Speed Operational Amplifier Layout Made Easy	sloa046
<b>Power Amplifiers and Buffers</b>	
Combining an Amplifier with the BUF634	sboa065
<b>Rail-to-Rail Amplifiers</b>	
Use of Rail-to-Rail Operational Amplifiers (Rev. A)	sloa039
A Single Supply Op Amp Circuit Collection	sloa058
<b>References</b>	
The Design and Performance of a Precision Voltage Reference Circuit for 14-bit and 16-bit A-to-D and D-to-A Converters	slyt168
Precision Voltage References	slyt183
<b>Switch Mode</b>	
Conditioning a Switch-Mode Power Supply Current Signal	sloa044
PWM Power Driver Modulation Schemes	sloa092
<b>Transimpedance</b>	
Comparison of Noise Performance of FET Transimpedance	sboa034
<b>Using TI Op Amps Filtering</b>	
FilterPro MFB and Sallen-Key Low-Pass Filter Design Program (Rev. A)	sbfa001
Analysis of the Sallen-Key Architecture (Rev. B)	sloa024
Active Low-Pass Filter Design (Rev. A)	sloa049
Using the Texas Instruments Filter Design Database	sloa062
Filter Design on a Budget	sloa065
Filter Design in Thirty Seconds	sloa093
More Filter Design on a Budget	sloa096
Active filters using current-feedback amplifiers	slyt081
<b>Video</b>	
Measuring Differential Gain and Phase	sloa040
Video Designs Using High-Speed Amplifiers	sloa057
Video Operational Amplifier	sboa069

## Data Conversion Application Reports



Title	Lit No.
<b>Analog Monitor and Control Circuitry</b>	
AMC7820REF: A Reference Design for DWDM Pump Lasers	sbaa072a
Using a SAR ADC for Current Measurement in Motor Control Applications	sbaa081
Choosing an Optocoupler for the ADS1202 Operating in Mode 1	sbaa088
Combining ADS1202 with FPGA Digital Filter for Current Measurement in Motor Control Applications	sbaa094
Interfacing the ADS1202 Modulator w/a Pulse Transformer in Galvanically Isolated	sbaa096
Designing with the THS1206 High-Speed Data Converter	sbaa094
Resetting Non-FIFO Variations of the 10-bit THS10064	sbaa144
Resetting Non-FIFO Variations of the 12-bit THS1206	sbaa145
Software Control of the ADS8364	sbaa155
Interfacing the ADS8361 to the TMS320VC5416 DSP	sbaa162
Interfacing the ADS8364 to the TMS320F2812 DSP	sbaa163
Interfacing the ADS8361 to the TMS320C6711 DSP	sbaa164
Interfacing the ADS8361 to the TMS320F2812 DSP	sbaa167
Using the ADS1202 Reference Design	sbaa186
Using the ADS7869 Reference Design Evaluation Module	sbaa231
Streamlining the Mixed-Signal Path with the Signal-Chain-On-Chip MSP430F169	slyt078
<b>Analog-to-Digital Converters</b>	
Dynamic Tests for ADC Performance	sbaa002
Tips for Using the ADS78xx Family of ADCs	sbaa003
Selecting an ADC	sbaa004
Programming Tricks for Higher Conversion Speeds Utilizing $\Delta\Sigma$ Converters	sbaa005
Giving Delta-Sigma Converters a Gain Boost with a Front-End Analog Gain Stage	sbaa006
ADS7809 Tag Features	sbaa007
Voltage Reference Scaling Techniques Increase Converter and Resolution Accuracy	sbaa008
DEM-ADS1210/11 Demo Board Tricks Evaluate ADS1211 Multiplexer Switch Response	sbaa009
Interfacing the ADS1210 with an 8x C51 Microcontroller	sbaa010
Accessing the ADS1210 Demo Board with Your PC	sbaa011
Overdriving the Inputs To The ADS1210, ADS1211, ADS1212, and ADS1213	sbaa012
Synchronization of External Analog Multiplexers with Delta-Sigma ADCs	sbaa013
Short Cycling the 8-Pin ADS78xx Family	sbaa014
Remove the DC Portion of Signals with the ADS7817	sbaa015
Guide for Delta-Sigma Converters: ADS1210, ADS1211, ADS1212, ADS1213	sbaa016
How to Get 23 bits of Effective Resolution from Your 24-bit Converter	sbaa017
Interfacing the ADS7822 to Syn. Serial Port of the 80x51 Microcontroller	sbaa018
Using the Continuous Parallel Mode with the ADS7824 and ADS7825	sbaa019
Customizing the DDC112 Evaluation Fixture	sbaa021
ADS121x ADC Applications Primer	sbaa022
Understanding The DDC112's Continuous and Non-Continuous Modes	sbaa024
The DDC112's Test Mode	sbaa025
Retrieving Data from the DDC112	sbaa026
Using External Integration Capacitors on the DDC112	sbaa027
Multi-DDC112 DUT Board for the DDC112 Evaluation Fixture	sbaa029
New Software For The DDC112 Evaluation Fixture	sbaa030
Using the ADS1201 Evaluation Board [745k]	sbaa031
Creating a Bipolar Input Range for the DDC112	sbaa034
DDC112UK DEMO BOARD	sbaa038
Comparing the ADS1201 to the CS5321 (745k)	sbaa039
Improved 60Hz Performance for ADS1211	sbaa040
Interfacing the ADS7870 and the MC68HC11E9 Analog to $\mu$ computer Made Easy	sbaa041
Coding Schemes used with Data Converters	sbaa042
CDAC Architecture gives ADC574 Pinout/Sampling, Low Power, New Input Ranges	sbaa043
Using the ADS7800 12-bit ADC with Unipolar Input Signals	sbaa044
Complete Temp Data Acquisition System from a Single +5V Supply	sbaa050
A Clarification of Use of High-Speed S/H to Improve Sampling ADC Performance	sbaa053
AB-174: Getting the Full Potential from your ADC (Rev. A)	sbaa069a
Measuring Temperature with the ADS1216, ADS1217, or ADS1218 (Rev. A)	sbaa073a
The Offset DAC	sbaa077
Understanding the ADS1252 Input Circuitry	sbaa082
ADS1240, 1241 App-Note: Accessing the Onboard Temp Diode in the ADS1240 / ADS1241	sbaa083
Overclocking the ADS1240 and ADS1241	sbaa084a
Understanding the ADS1251, ADS1253, and ADS1254 Input Circuitry	sbaa086
The Operation of the SAR-ADC Based on Charge Redistribution	slyt176
Keep an Eye on the LVDS Input Levels	slyt188

Title	Lit No.
Calibration Routines and Register Value Generation for the ADS121x Series	sbaa099
A Spreadsheet for Calculating the Frequency Response of the ADS1250-54	sbaa103a
Using Ceramic Resonators with the ADS1255/6	sbaa104
Clock Divider Circuit for the ADS1202 in Mode 3 Operation	sbaa105
ADC Gain Calibration - Extending the ADC Input Range	sbaa107
ADS5500, OPA695: PC Board Layout for Low Drivers Distortion High-Speed ADC	sbaa113
Data Capture with Multiple ADS1244 or ADS1245 Devices in Parallel	sbaa116
Data Converters for Industrial Power Measurements	sbaa117b
LVDS Outputs on the ADS527x	sbaa118
Using the ADSDeSer-50EVM to Deserialize ADS527x 10-Bit Outputs	sbaa119
Interfacing the ADS1241 to the MSP430F449	sbaa121
Reading Data from the ADS7862	sbaa138
Synchronizing the ADS1271	sbaa355
Solder Pad Recommendations for Surface-Mount Devices (Rev. A)	sbaa015a
Interfacing High-Speed LVDS Outputs of the ADS527x/ADS524x	sbaa104
Using TI FIFOs to Interface High-Speed Data Converters with TI TMS320 DSPs	sbaa003
Interfacing the TLV1549 10-bit Serial-Out ADC to Popular 3.3-V Microcontrollers	sbaa005
Microcontroller Based Data Acquisition Using the TLC2543 12-Bit Serial Out ADC	sbaa012
Interfacing the TLC2543 ADC to the TMS320C25 DSP	sbaa017
Signal Acquisition and Conditioning with Low Supply Voltages	sbaa018
Interfacing the TLV1544/1548 ADC to Digital Processors	sbaa022
Interfacing the TLV1544 ADC to the TMS320C50 DSP (Rev. A)	sbaa025a
Interfacing the TLV1572 ADC to the TMS320C203 DSP (Rev. B)	sbaa026b
Interfacing the TLV1544 Analog-to-Digital Converter to the TMS320C203 DSP	sbaa028a
Low-Power Signal Conditioning For A Pressure Sensor	sbaa034
Switched-Capacitor ADC Analog Input Calculations	sbaa036
Interfacing the TLV1562 Parallel ADC to the TMS320C54x DSP	sbaa040
Choosing an ADC and Op Amp for Minimum Offset	sbaa064
Interfacing the TLV1571/78 ADC to the TMS320C542 DSP	sbaa077
Interfacing the MSP430x1x(1) and TLV0831 (Rev. A)	sbaa092a
Interfacing the TLV2544/TLV2548 ADC to the TMS320C5402 DSP (Rev. A)	sbaa093a
Using the TMS320C5402 DMA Channels to Read From the TLV2548	sbaa095
Using the TMS320C5402 DMA Channels to Read from the TLV1570 ADC	sbaa097
Interfacing the TMS320C5402 DSP to the TLV2541 ADC and the TLV5636 DAC (Rev. A)	sbaa098a
Interfacing the TLV2544/TLV2548 ADC to the TMS320C31 DSP	sbaa101
Interfacing the ADS7822 to the TMS320C5402 DSP	sbaa107
SPI-Based Data Acquisition/Monitor Using the TLC2551 Serial ADC (Rev. A)	sbaa108a
Interfacing the TLV2541 ADC and the TLV5618A DAC to the TMS320C31 DSP	sbaa111
Interfacing the MSP430 and TLC549/1549 ADCs	sbaa112
Interfacing the ADS8320 ADC to the TMS320C5402 DSP	sbaa118
Implementing a Direct Thermocouple Interface with MSP430x4xx and ADS1240 (Rev. A)	sbaa125a
Interfacing the TLC3544/48 ADC to the MSP430F149 (Rev. A)	sbaa126a
Interfacing the ADS7842 ADC to the TMS320C5400 and TMS320C6000 DSPs Platforms	sbaa130
Reading the Configuration Registers of the 10-bit THS10064, THS1007, THS10082	sbaa143
Interfacing the ADS8364 ADC to the MSP430F149	sbaa150
Interfacing the TLC4541 to TMS320C6711 DSP	sbaa156
Interfacing the ADS8345 to TMS320C5416 DSP	sbaa160
Interfacing the TLC2552 and TLV2542 to the MSP430F149	sbaa168
Interfacing the ADS8320/ADS8325 to TMS320C6711 DSP	sbaa17
Interfacing the TLV2541 to the MSP430F149	sbaa171
Interfacing the ADS8383 to TMS320C6711 DSP	sbaa174
Interfacing the ADS8320/ADS8325 to TMS320C6711 DSP	sbaa175
Controlling the ADS8342 with TMS320 Series DSP's	sbaa176
Operating the 16-bit, 5MSPS ADS1605 at Double the Output Data Rate	sbaa180
Interfacing the MSOP8EVM to TMS320C6x Processors	sbaa190
Using ADS8411/2 (16-Bit 2MSPS SAR) as a Serial ADC	sbaa199
Interfacing the MSOP8EVM to TMS320C5x Processors	sbaa201
Interfacing the ADS1100 to the MSP430F413	sbaa206
Interfacing the MSOP8EVM to MSP430 Processors	sbaa209
Interfacing the ADS8402/ADS8412 to TMS320C6713 DSP	sbaa211
Interfacing the ADS8401/ADS8411 to TMS320C6713 DSP	sbaa212
Controlling the ADS7805 With TMS320 Series DSPs	sbaa229
Interfacing the ADS8371 to TMS320C6713 DSP	sbaa232
Interfacing Low Power Serial (SPI) ADCs to the MSP430F449	sbaa234
Using the ADS8380 with the TMS320C6713 DSP	sbaa240





## Data Conversion Application Reports

Title	Lit No.
Interfacing the ADS1251/52 to the MSP430	slaa242
Using the ADS7841 and ADS7844 with 15-Clock Cycles	slaa256
Interfacing the TLC4541 & the DAC7654 to the MSP430F449	slaa258
Connecting ADS8410/13 With Long Cable	slaa284
Multiplexing ADS8411	slaa285
A New Generation of Hall Sensors Including Delta-Sigma Modulators	slaa286
Evaluating the TLV2462 and TLV2772 as Drive Amps for the TLV2544/TLV2548 ADC	sloa048
Thermistor Temperature Transducer to ADC Application	sloa052
Pressure Transducer to ADC Application	sloa056
Implementing a CDC7005 Low Jitter Clock Solution for High Speed High IF ADC Dev	slwa034
Standard Procedure Direct Measurement Sub-picosecond RMS Jitter High-Speed ADC	slwa036
ADCs Support Multicarrier Systems	slwy001
Analogue-to-Digital Converters Support Multicarrier Systems	slwy001
14-Bit, 125-MSPS ADS5500 Evaluation	slyt074
Clocking High-Speed Data Converters	slyt075
Two-Channel, 500-kSPS Operation of the ADS8361	slyt082
ADS809 Analog-to-Digital Converter with Large Input Pulse Signal	slyt083
ADS82x ADC with Non-Uniform Sampling Clock	slyt089
Evaluation Criteria for ADSL Analog Front End	slyt091
Adjusting the A/D Voltage Reference to Provide Gain	slyt109
Using Direct Data Transfer to Maximize Data Acquisition Throughput	slyt111
Synchronizing Non-FIFO Variations of the THS1206	slyt115
Intelligent Sensor System Maximizes Battery Life: Interfacing MSP430F123, AD7822,	slyt123
A/D&D/A Conversion of PC Graphics & Component Video Signals	
Part 2: Software&Control	slyt129
Building a Simple Data Acquisition System Using the TMS320C31 DSP	slyt136
A/D and D/A Conversion of PC Graphics & Component Video Signals Part 1: Hardware	slyt138
Smallest DSP-Compatible ADC Provides Simplest DSP Interface	slyt148
Using Quad and Octal ADCs in SPI Mode	slyt150
New DSP Development Environment Includes Data Converter Plug-Ins	slyt158
Higher Data Throughput for DSP Analog-to-Digital Converters	slyt159
Efficiently Interfacing Serial Data Converters to High-Speed DSPs	slyt160
A Methodology of Interfacing Serial A-to-D Converters to DSPs	slyt175
Techniques for Sampling High-Speed Graphics with Lower-Speed A/D Converters	slyt184
Aspects of Data Acquisition System Design	slyt191
Low-Power Data Acquisition Sub-System Using the TI TLV1572	slyt192
Operating Multiple Oversampling Data Converters	slyt222
<b>Digital-to-Analog Converters</b>	
Interfacing The DAC714 To Microcontrollers Via SPI	sbaa023
High-Speed Data Conversion	sbaa045
Wideband Complementary Current Output DAC Single-Ended Interface	sbaa135
Interfacing the TLC5618A DAC to the TMS320C203 DSP	slaa033
Bipolar Voltage Outputs for the TLV56xx Family of DACs	slaa113
Solid State Voice Recorder Using Flash MSP430	slaa123
Interfacing with the DAC8541 DAC	slaa146
Interfacing the DAC7731 to the MSP430F149	slaa165
Building a Stable DAC External Reference Circuit	slaa172
Interfacing the DAC8534 to the TMS320VC33 DSP	slaa179
Interfacing the DAC8574 to the MSP430F449	slaa189
Interfacing the DAC8534EVM to TMS320C5x Processors	slaa191
Interfacing the DAC7654 to the MSP430F449	slaa213
Interfacing the DAC8811 to the MSP430F449	slaa238
Interfacing the DAC7554 to the MSP430F449	slaa252
Interfacing the DAC7558 to the MSP430F449	slaa261
Interfacing the TLV5639 DAC to the TMS320C31 DSP	slau071
DAC5686/DAC5687 Clock Generation Using PLL & External Clock Modes	slwa040a
Using SPI Synchronous Communication w/DACs: Interfacing the	
MSP430F149 & TLV5616	slyt137
<b>Codecs</b>	
Using the PGA Function in TSC210x/AIC26/AIC28/DAC26 Devices	slaa253
Programming Audio Power Up/Down on TSC210x & TLV320AIC26/28	slaa230a
<b>MicroSystem Mixed-Signal Data Converters</b>	
What Designers Should Know About Data Converter Drift	sbaa046
Principles of Data Acquisition and Conversion	sbaa051
Analogue-to-Digital Converter Grounding Practices Affect System Performance	sbaa052
Programming the MSC1210 (Rev. B)	sbaa076b

Title	Lit No.
MSC1210 Debugging Strategies	sbaa078
Debugging Using the MSC1210 Boot ROM Routines	sbaa079a
MSC1210 ROM Routines (Rev. B)	sbaa085b
MSC1210: In-Application Flash Programming	sbaa087
Programming the MSC1210 by Using a Terminal Program (Rev. A)	sbaa089a
Maximizing Endurance of MSC1210 Flash Memory	sbaa091
MSC1210: Incorporating the MSC1210 into Electronic Weight Scale Systems (Rev. B)	sbaa092b
MSC1210 Versatile Flash Programmer	sbaa093
ADC Offset in MSC12xx Devices (Rev. B)	sbaa097b
Using the MSC121x as a High-Precision Intelligent Temperature Sensor	sbaa100
Getting Started with the MSC1210	sbaa102a
MSC12xx Programming with SDCC	sbaa109
Ratiometric Conversions: MSC1210, 1211, 1212	sbaa110
Understanding the ADC Input on the MSC12xx	sbaa111b
MSC1211 / 12 DAC INL Improvement	sbaa112
A Complete Webserver on the MSC121x	sbaa114
MSC12xx Serial Programming Board	sbaa122
Using Crystal Oscillators with MSC12xx MicroSystem Products	sbaa123
Average Measurements with the MSC12xx	sbaa124
Improving MSC120x Temperature Measurements	sbaa126
Incremental Flash Memory Page Erase	sbaa137
Minimizing Power Consumption on the MSC12xx	sbaa139
High-Speed Data Acquisition with MSC12xx Devices	sbaa140
Implementing IIR Filters on the MSC12xx	sbaa142
Supply Voltage Measurement and ADS PSRR Improvement in MSC12xx Devices	slyt073
MSC1210 Debugging Strategies for High-Precision Smart Sensors	slyt110
<b>Touch Screen Controllers</b>	
ADS7843 Pen Interrupt	sbaa028
Touch Screen Controller Tips	sbaa036
Evaluating the ADS7846E: Using the DEM-ADS7843E/45E Evaluation Fixture	sbaa037
Using the ADS7846 Touch Screen Ctrl. with the Intel SA-1110 StrongArm Processor	sbaa070
Windows CE Touch and Keypad Device Drivers for the TSC2200	sbaa075
Applying the Current DAC on the TSC2000, TSC2200, TSC2300, and TSC2301 Touch Screen	sbaa098
Windows CE .NET Touch Screen, Keypad and Audio Device Drivers for the TSC2301	slaa169
TCS2301 WinCE Generic Drivers	slaa187
Programming Sequences and Tips for TSC2000/2200/230x Applications	slaa197
TSC2100 WinCE Generic Drivers	slaa198
TSC2101 Touch Screen, Battery and Audio WinCE Drivers	slaa200
Interface TSC Through McBSP	slaa214
TSC2101 WinCE 5.0 Drivers	slaa251
TSC2003 WinCE 5.0 Driver	slaa277
TSC2046 WinCE 5.0 Driver	slaa278
<b>Voiceband Codecs</b>	
Low Voltage Modem Platform Based on TMS320LC56	bpaa049
Designing with the TLC320AC01 Analog Interface for DSPs	slaa006
Common Sample Rate Selection For TLV320AIC12/13/14/15/20/21/24/25 Codecs	slaa009
Multiple TLC320AC01/02 Analog I/F Circuits on One TMS320C5x DSP Serial Port	slaa016
Evaluation Board for Interfacing the TLC320AD545 DSP Analog Interface Circuit (Rev. A)	slaa085a
Design Guidelines for the TLC320AD50	slaa087
Comparison of TI Voiceband Codecs for Telephony Applications	slaa088
Design Guidelines for the TLC320AD535/545	slaa090
Interfacing the TMS320C54x DSP to the TLC320AD535/545 Codecs	slaa091
Interfacing the TLV320AIC10/11 Codec to the TMS320C5402 DSP	slaa109
TLV320AIC12/13/14/15 CODEC Operating Under Stand-Alone Slave Mode	slaa142
Sample Code for Interfacing the TLV320AIC1106 CODEC with the TMS320C5402 DSP	slaa147
Demo/Test CODEC System with TLV320AIC20/21/24/25 EVM	slaa153
Interfacing the TLV320AIC12/13/14/15 Codec to the TMS320C5402y DSP	slaa154
Interface the TLV320AIC1110 CODEC With The TMS320C5402 DSP	slaa158
TMS320C54x DSP Reference Framework & Device Driver for the TLV320AIC20 HPA DC	slaa166
Interface with Voice-Band Codecs Using I2C	slaa173
Efficient Resampling Filters for the AIC111	slaa193
Hardware auto-identification&software auto-configuration for the	
TLV320AIC10 DSP Codec - a "plug-and-play" algorithm	slyt149a
Interfacing Two Analog Interface Circuits to One TMS320C5x Serial Port	spra268
TMS320C54xx McBSP to TLV320AIC24 Interface	spra957





ACF2101.....	47	ADS5220.....	66, 89	ADS7845.....	100	ADS8382.....	60, 87, 105, 109	DAC7558.....	72, 96, 110
ADS1000.....	54, 91	ADS5221.....	66, 89	ADS7846.....	100, 110	ADS8383.....	60, 87, 105, 109	DAC7571.....	71, 96
ADS1010.....	54, 91	ADS5232.....	66, 89	ADS7852.....	61, 90	ADS8401.....	60, 87, 105, 109	DAC7573.....	71, 96
ADS1012.....	54, 91	ADS5240.....	66, 89	ADS7861.....	61, 78, 90, 104	ADS8402.....	60, 87, 105, 109	DAC7574.....	71, 96
ADS1100.....	54, 88, 109	ADS5242.....	66, 89	ADS7862.....	61, 78, 90, 109	ADS8405.....	60, 87	DAC7611.....	71, 96
ADS1110.....	54, 88	ADS5270.....	66, 89	ADS7864.....	61, 78, 90, 104	ADS8406.....	60, 87	DAC7612.....	71, 96
ADS1112.....	54, 88	ADS5271.....	66, 89	ADS7866.....	61, 90	ADS8410.....	60, 87, 108, 110	DAC7613.....	71, 96
ADS1201.....	78, 86, 109	ADS5272.....	66, 89	ADS7867.....	62, 92	ADS8411.....	60, 87, 105, 108, 109	DAC7614.....	71, 96
ADS1202.....	76, 77, 78, 79, 88	ADS5273.....	66, 89	ADS7868.....	62, 93	ADS8412.....	60, 87, 105, 109	DAC7615.....	71, 96
ADS1203.....	76, 77, 78, 79, 88	ADS5277.....	67, 91	ADS7869.....	61, 76, 78, 90, 109	ADS8413.....	60, 87	DAC7616.....	71, 96
ADS1204.....	76, 78, 79, 88	ADS5410.....	66, 89	ADS7870.....	61, 78, 91, 109	ADS8481.....	59, 60, 86	DAC7617.....	71, 96
ADS1205.....	76, 78, 79, 88	ADS5413.....	66, 67, 89, 91	ADS7871.....	61, 78, 89	ADS8482.....	59, 60, 86	DAC7621.....	71, 96
ADS1208.....	76, 78, 79, 88	ADS5413-11.....	67, 91	ADS7881.....	61, 90, 105	ADS850.....	66, 88	DAC7624.....	71, 96
ADS1210.....	54, 86, 109	ADS5421.....	66, 88	ADS7886.....	61, 90	ADS8504.....	58, 61, 90, 105	DAC7625.....	71, 96
ADS1211.....	54, 86, 109	ADS5422.....	66, 88	ADS7887.....	62, 92	ADS8505.....	58, 60, 87, 105	DAC7631.....	71, 94
ADS1212.....	54, 86, 109	ADS5423.....	64, 66, 88	ADS7888.....	62, 93	ADS8508.....	58, 61, 90	DAC7632.....	71, 94
ADS1213.....	54, 86, 109	ADS5424.....	64, 66, 88, 108	ADS7890.....	60, 88	ADS8509.....	58, 60, 87	DAC7634.....	71, 95
ADS1216.....	54, 86, 104, 109	ADS5433.....	64, 66, 88	ADS7891.....	60, 88, 105	ADS900.....	67, 92	DAC7641.....	71, 94
ADS1217.....	54, 86, 104, 109	ADS5440.....	64, 66, 89	ADS800.....	66, 89	ADS901.....	67, 92	DAC7642.....	71, 94
ADS1218.....	54, 86, 104, 109	ADS5444.....	64, 66, 89	ADS801.....	66, 89	ADS930.....	67, 93	DAC7643.....	71, 94
ADS1222.....	54, 86	ADS5500.....	66, 85, 88, 109, 110	ADS802.....	66, 89, 90	ADS931.....	67, 92	DAC7644.....	71, 95
ADS1224.....	54, 86	ADS5520.....	66, 89	ADS803.....	67, 90, 105	AFE1230.....	107	DAC7654.....	71, 95, 110
ADS1225.....	54, 86	ADS5521.....	66, 89	ADS804.....	66, 89, 90, 105	AIC111.....	107, 110	DAC7664.....	71, 95
ADS1226.....	54, 86	ADS5522.....	66, 89	ADS805.....	66, 89, 105	AMC1210.....	76, 78, 79	DAC7714.....	71, 96
ADS1230.....	54, 86	ADS5541.....	66, 88	ADS807.....	66, 89	AMC6821.....	77, 84	DAC7715.....	72, 96
ADS1232.....	52, 54, 86	ADS5542.....	66, 88	ADS808.....	66, 89	AMC7823.....	61, 76, 78, 90	DAC7724.....	72, 96
ADS1234.....	52, 54, 86	ADS5545.....	65, 66, 89	ADS809.....	66, 89, 110	BUF602.....	14, 17, 19, 21, 42	DAC7725.....	72, 96
ADS1240.....	54, 86, 104, 109	ADS5546.....	65, 66, 89	ADS820.....	67, 92	BUF634.....	14, 17, 41, 42, 108	DAC7731.....	71, 94, 110
ADS1241.....	54, 86, 104, 109	ADS5553.....	66, 88	ADS821.....	67, 91	DAC1220.....	68, 94, 106	DAC7734.....	71, 95
ADS1242.....	54, 86	ADS7800.....	61, 90, 109, 109	ADS822.....	67, 91	DAC1221.....	68, 95, 106	DAC7741.....	71, 94
ADS1243.....	54, 86	ADS7804.....	61, 91, 104	ADS823.....	67, 91	DAC2900.....	75, 97	DAC7742.....	71, 94
ADS1244.....	54, 86, 109	ADS7805.....	60, 88, 104	ADS825.....	67, 91	DAC2902.....	75, 95	DAC7744.....	71, 95
ADS1245.....	54, 86, 109	ADS7806.....	61, 91	ADS826.....	67, 91	DAC2904.....	75, 95	DAC7800.....	72, 95
ADS1250.....	54, 86, 109	ADS7807.....	60, 88	ADS828.....	67, 91	DAC2932.....	75, 95	DAC7801.....	72, 95
ADS1251.....	54, 86, 104, 109, 110	ADS7808.....	61, 91	ADS830.....	67, 92	DAC5571.....	73, 97	DAC7802.....	72, 95
ADS1252.....	54, 86, 104, 109	ADS7809.....	60, 88, 109	ADS831.....	67, 92	DAC5573.....	73, 97	DAC7811.....	71, 95
ADS1253.....	54, 86, 104, 109	ADS7810.....	61, 90	ADS8320.....	60, 87, 105, 109	DAC5574.....	73, 97	DAC7821.....	71, 95
ADS1254.....	54, 86, 104, 109	ADS7811.....	60, 87	ADS8321.....	60, 87, 105	DAC5652.....	74, 75, 97	DAC7822.....	71, 95
ADS1255.....	54, 86, 109	ADS7812.....	62, 91	ADS8322.....	60, 87, 105	DAC5662.....	74, 75, 95	DAC8043.....	72, 95
ADS1256.....	54, 86	ADS7813.....	60, 88	ADS8323.....	60, 87, 105	DAC5672.....	74, 75, 95	DAC811.....	71, 96
ADS1258.....	52, 54, 86	ADS7815.....	60, 87	ADS8324.....	61, 89, 105	DAC5674.....	75, 95	DAC813.....	71, 96
ADS1271.....	53, 54, 86, 100, 104	ADS7816.....	61, 90	ADS8325.....	9, 60, 87, 105, 109	DAC5675.....	75, 85, 95	DAC8501.....	72, 94, 106
ADS1274.....	54, 86	ADS7817.....	61, 90, 109	ADS8326.....	60, 88	DAC5686.....	75, 94, 110	DAC8531.....	72, 94, 106
ADS1286.....	62, 91	ADS7818.....	61, 90	ADS8327.....	59, 60, 87	DAC5687.....	75, 94, 110	DAC8532.....	72, 94, 106
ADS1601.....	54, 87, 104	ADS7822.....	61, 91, 109	ADS8328.....	59, 60, 87	DAC6571.....	72, 97	DAC8534.....	72, 95, 106, 110
ADS1602.....	54, 87, 104	ADS7823.....	61, 91	ADS8329.....	60, 87	DAC6573.....	73, 97	DAC8541.....	72, 94, 110
ADS1605.....	53, 54, 87, 104, 109	ADS7824.....	62, 91, 109	ADS8330.....	60, 87	DAC6574.....	73, 97	DAC8544.....	72, 94
ADS1606.....	54, 87, 104	ADS7825.....	60, 88, 109	ADS8341.....	60, 88	DAC712.....	71, 94	DAC8550.....	70, 72, 94
ADS1610.....	53, 54, 87, 104	ADS7826.....	62, 92	ADS8342.....	60, 87, 108, 109	DAC714.....	71, 94, 110	DAC8551.....	70, 72, 94
ADS1625.....	54, 86, 104	ADS7827.....	62, 93	ADS8343.....	60, 88	DAC715.....	71, 94	DAC8552.....	70, 72, 94
ADS1626.....	54, 86, 104	ADS7828.....	61, 91	ADS8344.....	60, 88	DAC716.....	71, 94	DAC8554.....	70, 72, 94
ADS2806.....	66, 89	ADS7829.....	61, 91	ADS8345.....	60, 88, 109	DAC7512.....	72, 96, 106	DAC8555.....	70, 72, 94
ADS2807.....	66, 89	ADS7830.....	62, 93	ADS8361.....	26, 60, 78, 87, 105	DAC7513.....	72, 96, 106	DAC8571.....	72, 94
ADS5102.....	67, 91	ADS7834.....	61, 90	ADS8364.....	60, 78, 87, 105, 109	DAC7541.....	72, 95	DAC8574.....	72, 95, 110
ADS5103.....	67, 91	ADS7835.....	61, 90	ADS8365.....	60, 78, 87	DAC7545.....	72, 96	DAC8580.....	72, 94, 106
ADS5120.....	67, 91, 92	ADS7841.....	61, 91, 104, 110	ADS8370.....	58, 60, 87, 105	DAC7551.....	72, 96	DAC8581.....	72, 94
ADS5121.....	67, 91, 92	ADS7842.....	61, 90, 109	ADS8371.....	60, 87, 105, 109	DAC7552.....	72, 96	DAC8801.....	70, 71, 95
ADS5122.....	67, 91	ADS7843.....	100, 110	ADS8372.....	58, 60, 87, 105	DAC7553.....	72, 96	DAC8802.....	70, 71, 95
ADS5203.....	67, 91	ADS7844.....	61, 91, 104, 110	ADS8380.....	60, 87, 105, 110	DAC7554.....	72, 96, 106, 110	DAC8803.....	70, 71, 95
ADS5204.....	67, 91			ADS8381.....	60, 80, 87, 105			DAC8806.....	70, 71, 95



DAC8811.....70, 71, 94, 110	INA145 .....25, 25, 26	LMV358.....112	OPA381 .....10, 11, 12, 50	OPAy349 .....9
DAC8812.....70, 71, 94	INA146 .....25, 26	LMV393 .....22, 24	OPA445/B .....42	OPAy350 .....10, 11, 12, 13, 50
DAC8814.....70, 71, 94	INA148 .....26	LMV824.....112	OPA452 .....42	OPAy354 .....16, 17, 19, 21
DAC8820.....70, 71, 94	INA152 .....26, 27, 50	LOG101 .....46	OPA453 .....42	OPAy355 ..14, 16, 17, 19, 21, 50
DAC8822.....71, 94	INA155 .....31, 50	LOG102 .....46	OPA541 .....42	OPAy356 .....16, 17, 19, 21
DAC8830.....69, 71, 94	INA156 .....31	LOG104 .....46	OPA544 .....42	OPAy357 .....17, 19, 21
DAC8831.....69, 71, 94	INA157 .....26, 31, 50	LOG112 .....46	OPA547 .....41, 42	OPAy358 .....14, 17, 19, 21, 50
DAC8871.....69, 71, 94	INA159 .....26, 50	LOG114 .....46	OPA548 .....41, 42	OPAy363...9, 11, 12, 13, 50, 101
DAC8881.....71, 94	INA163 .....32	LOG2112 .....46	OPA549 .....41, 42	OPAy364 .....10
DAC900.....75, 97	INA166 .....32	LP211 .....24	OPA551 .....42	OPAy365 ..9, 10, 11, 12, 13, 50
DAC902.....75, 95	INA168 .....28	LP2901 .....24	OPA552 .....42	OPAy373 .....9, 13
DAC904.....75, 95	INA169 .....27, 28	LP311 .....24	OPA561 .....42	OPAy379 .....8, 9, 12, 13
DAC908.....75, 97	INA170 .....27, 28	LP339 .....24	OPA567 .....41, 42	OPAy380 ..10, 11, 12, 14, 17, 18
DDC101.....54, 86	INA19x .....27, 28	LPV324 .....112	OPA569 .....41, 42	OPAy381 .....10, 11, 12, 50
DDC112.....54, 86, 109	INA2126 .....31, 32	LT1013/1013D .....112	OPA615 .....14, 18, 19, 21	OPAy683 .....14, 16, 19, 21
DDC114.....54, 86	INA2132 .....26	LT1014/1014D .....112	OPA627 .....7, 10, 11, 12, 50	OPAy684 .....14, 16, 19, 21
DDC118.....54, 86	INA2133 .....26	MC1458 .....112	OPA633 .....42	OPAy690 .....14, 16, 19, 21
DDC232.....54	INA2134 .....26	MC3403 .....112	OPA637 .....10, 11, 12	OPAy691 .....14, 17, 19, 21
DF1704.....100	INA2137 .....26	MPA4609 .....18	OPA656 .....14, 16, 17, 18, 21	OPAy694 .....14, 17, 19, 21
DIT4192.....99	INA2143 .....26	MSC1200 .....56	OPA657 .....14, 16, 18	OPAy703 .....12
DIX4192.....99	INA217 .....32	MSC1201 .....55, 56	OPA683 .....14, 16, 19, 21	OPAy725 .....12
DRV101.....43	INA2321 .....31	MSC1202 .....55, 56	OPA684 .....14, 16, 19, 21	OPAy727/8 .....10, 11, 12, 50
DRV102.....43	INA2322 .....31	MSC1210 .....56, 110	OPA690 .....14, 16, 19, 21	OPAy734 .....9, 10, 12
DRV103.....43	INA2331 .....31	MSC1211 .....56, 110	OPA691 .....14, 17, 19, 21	OPAy735 .....10, 12, 50
DRV104.....43	INA2332 .....30, 31	MSC1212 .....56	OPA692 .....14, 42	OPAy820 .....14, 16, 19, 21, 50
DRV134.....26	INA321 .....31	MSC1213 .....56	OPA693 .....17, 19, 21, 42	OPAy832 .....14, 17, 19, 21, 42
DRV135.....26	INA322 .....31	MSC1214 .....56	OPA694 .....14, 17, 19, 21	OPAy846 .....16, 18
DRV590.....43	INA326 .....30, 31, 50	MSC12xx .....2, 3, 5, 110	OPA695 ..14, 17, 19, 21, 50, 109	OPT101 .....47
DRV591.....43	INA327 .....30, 31	MSC121x .....110	OPA698 .....14, 16, 18, 50, 85	PCM1600 .....98
DRV592.....43	INA330 .....31	MSP430 ..23, 83, 102, 109, 110	OPA699 .....14, 16, 18, 85	PCM1602 .....98
DRV593.....43	INA331 .....31, 50	MSP430F449 ..102, 109, 110	OPA727 .....10, 11, 12, 50	PCM1602K .....98
DRV594.....43	INA332 .....30, 31	OPA124 .....10, 11, 12	OPA735 .....10, 12, 50	PCM1604 .....98
DSD1608.....98	INA337 .....31	OPA227 .....10, 11, 12, 50	OPA820 .....14, 16, 19, 21, 50	PCM1606 .....98
DSD1702.....98	INA338 .....31	OPA228 .....11, 50	OPA830 .....14	PCM1608K .....98
INA101.....32	ISO122 .....48	OPA2544 .....42	OPA832 .....14, 17, 19, 21, 42	PCM1680 .....98
INA103.....25, 32	ISO124 .....48	OPA2613 .....14, 16, 18, 50	OPA842 .....14, 16, 19, 21, 50	PCM1710 .....98
INA110.....32	ISO150 .....48	OPA2614 .....14, 16, 18	OPA843 .....14, 16, 50	PCM1716/28 .....98
INA111.....32	IVC102.....47	OPA2652 .....14, 16	OPA847 .....14, 16, 18, 50	PCM1719 .....98
INA114.....32	LF353 .....112	OPA2674 .....17, 18	OPA860 .....14, 18	PCM1720 .....98
INA115.....32	LM111 .....23	OPA2677 .....14, 16, 18	OPA861 .....14, 18, 19, 21	PCM1723 .....98
INA116.....29, 32	LM139/139A .....112	OPA2690 .....50	OPAy130 .....12	PCM1725 .....98
INA117.....25, 26	LM193 .....24	OPA277 .....9, 10, 11, 12, 50	OPAy131 .....12	PCM1727 .....98
INA118.....31, 32	LM211 .....22, 23	OPA2822 .....14, 16, 18, 50	OPAy132 .....10, 11, 12	PCM1733 .....98
INA119x .....112	LM239/239A .....112	OPA300 .....13, 14, 16, 17, 50	OPAy137 .....12	PCM1737/39 .....98
INA20x .....28	LM2901 .....24	OPA333 .....8, 9, 10, 13	OPAy227 .....10, 11, 12, 50	PCM1738/30 .....98
INA121 .....32	LM2902 .....112	OPA335 .....10, 50	OPAy228 .....10, 11, 12, 50	PCM1740 .....98
INA122 .....25, 31, 32	LM2903 .....24	OPA336 .....9, 10, 12, 13, 50	OPAy234 .....10, 12	PCM1741 .....98
INA125 .....29, 31, 32	LM2904 .....112	OPA337 .....13	OPAy237 .....12	PCM1742 .....98
INA126 .....31, 32	LM293/293A .....112	OPA338 .....13	OPAy241 .....9, 10, 12	PCM1742K .....98
INA128 .....29, 32, 50	LM306 .....23	OPA340...9, 10, 11, 12, 13, 50	OPAy244 .....9, 12	PCM1744 .....98
INA129 .....29, 32	LM311 .....23	OPA350 .....10, 11, 12, 13, 50	OPAy251 .....9, 10, 12	PCM1748 .....98
INA131 .....32	LM324/324A .....112	OPA353 .....13	OPAy277 .....9, 10, 11, 12, 50	PCM1748K .....98
INA132 .....25, 26	LM3302 .....24	OPA355 ..14, 16, 17, 19, 21, 50	OPAy300/301..13, 14, 16, 17, 50	PCM1753/54/55 .....98
INA133 .....26	LM339/339A .....112	OPA358 .....14, 17, 19, 21, 50	OPAy333 .....8, 9, 10, 13	PCM1770 .....98
INA134 .....26	LM358/358A .....112	OPA360 .....14, 19, 21	OPAy334 .....9, 10	PCM1771 .....98
INA137 .....26	LM393/393A .....112	OPA361 .....14, 19, 20, 21	OPAy335 .....10, 50	PCM1772 .....98
INA138 .....28	LMV321 .....112	OPA363...9, 11, 12, 13, 50, 101	OPAy336 .....9, 10, 12, 13, 50	PCM1773 .....98
INA139 .....27, 28	LMV324/S .....112	OPA365...9, 10, 11, 12, 13, 50	OPAy340 ..9, 10, 11, 12, 13, 50	PCM1780/81/82 .....98
INA141 .....32	LMV331 .....22, 24	OPA373/4 .....9, 13	OPAy347 .....9	PCM1792/4 .....98
INA143 .....26	LMV339 .....22, 24	OPA379 .....8, 9, 12, 13	OPAy348 .....9	PCM1796/8 .....98



PCM1800	99	TAS5186	37, 40	THS6182	18	TLC5510	67, 93	TLV320AIC28	99
PCM1801	99	TAS5504	40	THS6184	14, 15, 18	TLC5510A	67, 93	TLV320AIC32	99
PCM1802	99	TAS5508	40	THS7303	18, 19, 21	TLC5540	67, 92	TLV320AIC33	99
PCM1804	99, 105	THS0842	67, 92	THS7313	18, 19, 21	TLC5615	73, 97	TLV320DAC23	98, 106
PCM1850	99	THS10064	67, 92, 105, 109	THS7353	18, 19, 20, 21	TLC5618A	85, 106, 110	TLV320DAC26	98
PCM3000/1	100	THS1007	67, 92, 105, 109	THS7530	14, 17, 35	TLC5620	73, 97	TLV3401	22, 23, 24
PCM3002	100, 107	THS10082	67, 92, 105, 109	THS9000/1	18	TLC5628	73, 97	TLV3491	22, 23, 24
PCM3003	100	THS1009	67, 92, 105	TIVy675	21	TLC7135	54, 89	TLV3501	22, 23
PCM3006	100	THS1030	67, 92	TL3016	22, 23	TLC7225	73, 97	TLV3701	22, 23, 24
PCM3008	100	THS1031	67, 92	TL3116	23	TLC7226	73, 85, 97	TLV5535	67, 92
PCM3010	99	THS1040	67, 91	TL331	24	TLC7524	73, 97	TLV5580	92
PCM3052A	99	THS1041	67, 91	TL441	46	TLC7528	73, 97	TLV5604	72, 97, 106
PCM3500/1	100	THS1206	66, 90, 105, 109	TL712	22, 23	TLC7628	73, 97	TLV5606	72, 97, 107
PCM4104	98	THS1206-EP	85, 90	TL714	22, 23	TLE2027	10, 11, 12, 50	TLV5608	72, 97, 107
PCM4108	98	THS1207	66, 90, 105	TLC0820A	62, 93	TLE202x	12	TLV5610	72, 96, 107
PCM4201	99	THS12082	66, 90, 105	TLC0831	62, 93	TLM3302	24	TLV5613	72, 95
PCM4202	99, 105	THS1209	66, 90, 105	TLC0832	62, 93	TLV0831	62, 93, 109	TLV5614	72, 96, 107
PCM4204	99, 105	THS1215	66, 89	TLC0834	62, 93	TLV0832	62, 93	TLV5616	72, 96, 107, 110
PGA103	33	THS1230	66, 89	TLC0838	62, 93	TLV0834	62, 93	TLV5617A	72, 97, 107
PGA202	33	THS1401	66, 85, 88, 105	TLC08x	12	TLV0838	62, 93	TLV5618A	72, 85, 96, 107, 109
PGA203	33	THS1403	66, 85, 88, 105	TLC1078	9, 10	TLV1504	62, 92, 106	TLV5619	72, 85, 95, 96
PGA204	33	THS1408	66, 85, 88, 105	TLC1514	62, 92, 105	TLV1508	62, 92, 106	TLV5620	73, 97
PGA205	33	THS14F01	66, 88, 105	TLC1518	62, 92, 106	TLV1543	62	TLV5621	73, 97
PGA206	33	THS14F03	66, 88, 105	TLC1541	62, 92	TLV1544	62, 92, 109	TLV5623	73, 97, 107
PGA207	33	THS3091/5	16	TLC1542	62, 92	TLV1548	62, 85, 92	TLV5624	73, 97, 107
PGA2500	40	THS3092/6	17	TLC1543	62, 85, 92	TLV1549	62, 109	TLV5625	73, 97, 107
PGA309	33, 44, 108	THS3110/11	14, 16	TLC1549	62, 92	TLV1562	67, 92, 109	TLV5626	73, 97, 107
PLL1700	100	THS3112/15	14, 16	TLC1550	62, 92	TLV1570	62, 92, 106, 109	TLV5627	73, 97
PLL1705	100	THS3120/1	14, 16	TLC1551	62, 92	TLV1571	62, 92, 106, 109	TLV5628	73, 97
PLL1706	100	THS3122/25	14, 16	TLC220x	11, 12	TLV1572	62, 92, 106, 109, 110	TLV5629	73, 97, 107
RCV420	44	THS3201	14, 17, 21, 85	TLC2543	61, 85, 91, 109	TLV1578	62, 92, 106	TLV5630	72, 96, 107
REF02A	81	THS3202	14, 21	TLC2551	61, 90, 106, 109	TLV2211	10	TLV5631	72, 97, 107
REF02B	81	THS4001	14	TLC2552	61, 90, 106, 109	TLV224x	9	TLV5632	73, 97, 107
REF102A	81	THS4011/12	16	TLC2554	61, 90, 106	TLV2302	23, 24	TLV5633	72, 95
REF102B	81	THS4031/32	16	TLC2555	61, 90, 106	TLV2352	24	TLV5636	72, 95, 107, 109
REF102C	81	THS4051/52	16	TLC2558	61, 90, 106	TLV237x	12	TLV5637	72, 97, 107
REF1112	80, 81	THS4081/82	16	TLC2574	61, 90, 106	TLV238x	12	TLV5638	72, 85, 96, 107
REF200	80, 81	THS4120/21	14	TLC2578	61, 91, 106	TLV2401	81	TLV5639	72, 95, 110
REF29xx	80, 81	THS4130/31	17, 50	TLC320AD545	110	TLV240x	9, 12	TLV571	62, 93
REF30xx	80, 81	THS4140/41	14	TLC320AD50	107, 110	TLV245x	9	TMP100	84
REF31xx	80, 81	THS4271/75	16, 85	TLC320AIC24	113	TLV246x	9	TMP101	84
REF32xx	80, 81	THS4281	9, 13, 19, 50	TLC320AIC25	113	TLV247x	9	TMP105	82, 83, 84
REF33xx	81	THS4302	14, 17	TLC339	22, 24	TLV2541	61, 90, 106, 109	TMP106	82, 83, 84
SRC4184	99	THS4303	17	TLC352	22, 24	TLV2542	61, 90, 106, 109	TMP121	84
SRC4190	99	THS4304	16	TLC3541	60, 89, 106	TLV2543	61, 91	TMP122	84
SRC4192	99	THS4502/03	17, 50, 85	TLC3544	61, 89, 106, 109	TLV2544	61, 90, 106, 109, 110	TMP123	84
SRC4193	99	THS4508	14, 17, 50	TLC3545	60, 88, 106	TLV2545	61, 90, 106	TMP124	84
SRC4194	99	THS4509	14, 17, 50	TLC3548	61, 89, 106	TLV2548	61, 85, 91, 106, 109	TMP125	84
SRC4382	99	THS4511	14, 15, 17, 50	TLC3574	60, 89, 106	TLV2553	61, 90, 106	TMP141	84
SRC4392	99	THS4513	14, 17, 50	TLC3578	61, 89, 106	TLV2556	61, 90, 106	TMP175	82, 83, 84
TAS5010	40	THS4520	17	TLC3702	22, 23	TLV2702	23, 24	TMP75	82, 83, 84
TAS5012	40	THS4631	14, 16, 17, 18	TLC372	22, 24	TLV278x	9	TMP300	82, 84
TAS5086	40	THS5641A	75, 97	TLC393	22, 23	TLV3011	22, 23, 24, 80	TPA01722	39
TAS5111	37, 40	THS5651A	75, 97	TLC4541	60, 87, 106, 109, 110	TLV3012	23, 24, 80	TPA0211	37, 39
TAS5112	37, 40	THS5661A	75, 95	TLC4545	60, 87, 106	TLV320AIC10	107, 110	TPA0212	38
TAS5121	37, 40	THS5671A	95	TLC541	62, 93	TLV320AIC11	107, 110	TPA0213	39
TAS5122	37, 40	THS6012	18	TLC542	62, 93	TLV320AIC22C	107	TPA0233	39
TAS5142	37, 40	THS6022	18	TLC545	62, 93	TLV320AIC23	107	TPA02522	38
TAS5152	37, 40	THS6042/43	18	TLC548	62, 93	TLV320AIC23B	107	TPA0253	37, 39
TAS5182	37, 40	THS6132	18	TLC549	62, 93, 109	TLV320AIC26	99, 110	TPA1517	37, 38



TPA152 .....37, 39	TPA3008D2 .....37, 38	TPA721 .....39	VCA2616/2611 .....35
TPA2000D1 .....38	TPA3100D2 .....37, 38	TPA731 .....39	VCA2617 .....14, 34, 35
TPA2000D2 .....38	TPA3101D2 .....37, 38	TPA741 .....39	VCA2618 .....35
TPA2000D4 .....38	TPA4411 .....37, 39	TPA751 .....39	VCA2619 .....35
TPA2001D1 .....38	TPA6010A4 .....37, 38	TSC2000 .....100	VCA810 .....14, 17, 35
TPA2001D2 .....38	TPA6011A4 .....37, 38	TSC2003 .....100	VCA8613 .....14, 35, 108
TPA2005D1 .....37, 38	TPA6017A2 .....37, 38	TSC2046 .....100	VCA8617 .....14, 35, 108
TPA2008D2 .....38	TPA6030A4 .....37, 38	TSC2100 .....100	XTR105 .....44
TPA2010D1 .....37, 38	TPA6100A2 .....39	TSC2101 .....100	XTR106 .....44
TPA2012D2 .....37, 38	TPA6101A2 .....39	TSC2102 .....100	XTR108 .....44, 45
TPA2032D1 .....38	TPA6102A2 .....39	TSC2111 .....100	XTR110 .....44
TPA2033D1 .....38	TPA6110A2 .....39	TSC2200 .....100	XTR112 .....44
TPA2034D1 .....38	TPA6111A2 .....39	TSC2300 .....100	XTR114 .....44
TPA3001D1 .....37, 38	TPA6112A2 .....39	TSC2301 .....100	XTR115 .....44
TPA3002D2 .....37, 38	TPA6120A2 .....37, 39	TSC2302 .....100	XTR116 .....44
TPA3003D2 .....37, 38	TPA6203A1 .....37, 39	VCA2612 .....14, 35	XTR300 .....44, 45
TPA3004D2 .....37, 38	TPA6204A1 .....37, 39	VCA2613 .....35	
TPA3005D2 .....37, 38	TPA6211A1 .....37, 39	VCA2614 .....35	
TPA3007D1 .....37, 38	TPA711 .....39	VCA2615 .....14, 34, 35	

## Quality Assurance

Continual focus on quality and reliability are elements of TI's commitment to customers. In 1995, TI's Semiconductor Group Quality System Program was launched. This comprehensive quality system is utilized to meet and exceed global customer and industry requirements.

TI recognizes the importance of advancing industry standards and is committed to working on regulatory as well as U.S. and international voluntary standards. As an active member of numerous global industry associations and with a strong commitment to the environment, TI has emerged as a leader with its Lead (Pb)-Free programs. An initiative begun in the 1980s to find alternative materials for products has resulted in the majority of TI products now being available Pb-free and Green.

For all of your lead (Pb)-free questions, visit: [www.ti.com/quality](http://www.ti.com/quality)





## TI Worldwide Technical Support

### Internet

#### TI Semiconductor Product Information Center Home Page

support.ti.com

#### TI Semiconductor KnowledgeBase Home Page

support.ti.com/sc/knowledgebase

## Product Information Centers

### Americas

Phone	+1(972) 644-5580
Fax	+1(972) 927-6377
Internet/Email	support.ti.com/sc/pic/americas.htm

### Europe, Middle East, and Africa

Phone	
Belgium (English)	+32 (0) 27 45 54 32
Finland (English)	+358 (0) 9 25173948
France	+33 (0) 1 30 70 11 64
Germany	+49 (0) 8161 80 33 11
Israel (English)	180 949 0107
Italy	800 79 11 37
Netherlands (English)	+31 (0) 546 87 95 45
Russia	+7 (0) 95 98 10 701
Spain	+34 902 35 40 28
Sweden (English)	+46 (0) 8587 555 22
United Kingdom	+44 (0) 1604 66 33 99
Fax	+(49) (0) 8161 80 2045
Internet	support.ti.com/sc/pic/euro.htm

### Japan

Fax	International	+81-3-3344-5317
	Domestic	0120-81-0036
Internet/Email	International	support.ti.com/sc/pic/japan.htm
	Domestic	www.tij.co.jp/pic

### Asia

Phone	
International	+886-2-23786800
Domestic	<u>Toll-Free Number</u>
Australia	1-800-999-084
China	800-820-8682
Hong Kong	800-96-5941
India	+91-80-41381665 (Toll)
Indonesia	001-803-8861-1006
Korea	080-551-2804
Malaysia	1-800-80-3973
New Zealand	0800-446-934
Philippines	1-800-765-7404
Singapore	800-886-1028
Taiwan	0800-006800
Thailand	001-800-886-0010
Fax	+886-2-2378-6808
Email	tiasia@ti.com or ti-china@ti.com
Internet	support.ti.com/sc/pic/asia.htm

**Safe Harbor Statement:** This publication may contain forward-looking statements that involve a number of risks and uncertainties. These "forward-looking statements" are intended to qualify for the safe harbor from liability established by the Private Securities Litigation Reform Act of 1995. These forward-looking statements generally can be identified by phrases such as TI or its management "believes," "expects," "anticipates," "foresees," "forecasts," "estimates" or other words or phrases of similar import. Similarly, such statements herein that describe the company's products, business strategy, outlook, objectives, plans, intentions or goals also are forward-looking statements. All such forward-looking statements are subject to certain risks and uncertainties that could cause actual results to differ materially from those in forward-looking statements. Please refer to TI's most recent Form 10-K for more information on the risks and uncertainties that could materially affect future results of operations. We disclaim any intention or obligation to update any forward-looking statements as a result of developments occurring after the date of this publication.

**Important Notice:** The products and services of Texas Instruments Incorporated and its subsidiaries described herein are sold subject to TI's standard terms and conditions of sale. Customers are advised to obtain the most current and complete information about TI products and services before placing orders. TI assumes no liability for applications assistance, customer's applications or product designs, software performance, or infringement of patents. The publication of information regarding any other company's products or services does not constitute TI's approval, warranty or endorsement thereof.

**Trademarks in this issue:** Technology for Innovators, the black/red banner, C2000, C28x, C5x, C5000, C54x, C55x, C6000, C62x, C64x, C67x, Code Composer Studio, DaVinci, Difet, e-trim, MicroStar Junior, NanoStar, OMAP, PowerPAD, PurePath Digital, TINA-TI, TMS320, TMS320C5x, TMS320C54x, TMS320C6000 and Zero-Crossover are trademarks of Texas Instruments. All other trademarks are the property of their respective owners.

A062706

© 2006 Texas Instruments Incorporated

Printed in U.S.A. by Colonial Press Int'l, Miami, FL.

Printed on recycled paper.



# Great Selection of Products!

[www.ti.com/selection](http://www.ti.com/selection)

Product Selection Guides  
Available for Ordering and  
Downloading Now:

- **NEW** Amplifier and Data Converter
- DSP
- Interface
- Logic
- Low-Power RF
- MSP430
- Power Management



**Texas Instruments Incorporated**

14950 FAA Blvd.  
Fort Worth, Texas 76155-9951

Address service requested

PRSR STD  
U.S. POSTAGE  
**PAID**  
DALLAS, TEXAS  
PERMIT NO. 2758